

ROBOTIC CATCHING ARM USING MICROCONTROLLER

Niranjan Singh¹, Shrikant Kumar², Pranali Mogare³, Khushboo Chirkute⁴, Charul Khode⁵

⁶ Prof. (Mrs.) P.U.Chati

^{1,2,3,4,5}Student, ⁵Professor, Department of Electronics and Tele-Communication

Priyadarshini collage of engineering, Nagpur, Maharashtra

Abstract - Nowadays Robots are becoming more important and useful over a period of time and have wide range of applications--from manufacturing, to surgery, to handling the hazardous chemicals. Pick n place robots manufacture the printed circuit board (PCB) with great accuracy. Almost every unmanned space probe ever launched was a robot. This paper will address one of those problems: positional control. The wireless communication technologies enabled for controlling and monitoring the robot. This paper discusses a protocol which intimates the information if any object is available in front of robotic vehicle, the user send command from system to pick and place robot. This paper discuss controlling robotic mechanism which is mainly controlled by using authorized person with the help of pc or laptop.

Key Words: Pick and Place Robot, wireless Communication Protocol.

1. INTRODUCTION

The project is designed to develop a pick n place robotic vehicle with a catching gripper. For example, it can safely handle hazardous chemical easily and can handle explosives carefully. This pick and place robot is RF controlled also it is a microcontroller based mechatronic system that detects the object, picks that object from source location and places at desired location.

At the transmitting end we are using laptop, commands are sent by the laptop to the receiver to control the movement of the robot either to move forward, reverse and left or right etc. At the receiving end four motors are interfaced to the microcontroller where two of them are used for arm and gripper movement of the robot while the other two are for the body movement. We are using different sensors here like pressure sensor and force sensor to sense the object that we are going to catch by the arm.

2. THE OVERALL SYSTEM PLAN

We are using microcontroller at mega 16 to control the motors movement. We send control data using laptop. A transmitter receiver section is connected to the laptop. This section send and receive data using RF frequency. On system side, Microcontroller is interfaced with 2 motor driver. With each motor driver 2 motor is connected. Since the output current through micro controller is very low when compared to the requirement current for the motors. The require power is 1 Amp and output current of micro controller is in milliamps. Therefore micro controller can't drive motors directly. Here we need a driver which is used between the motor and controller.

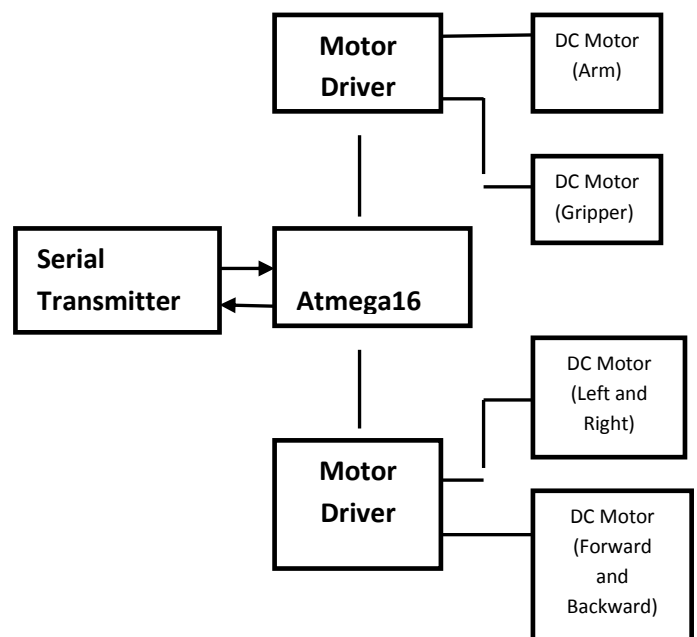

Fig.(A)Block Diagram of Proposed System

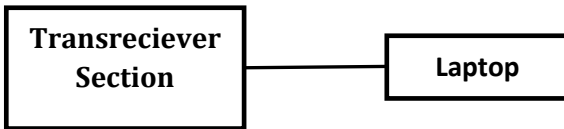

Fig.(B)Block Diagram of Control Section

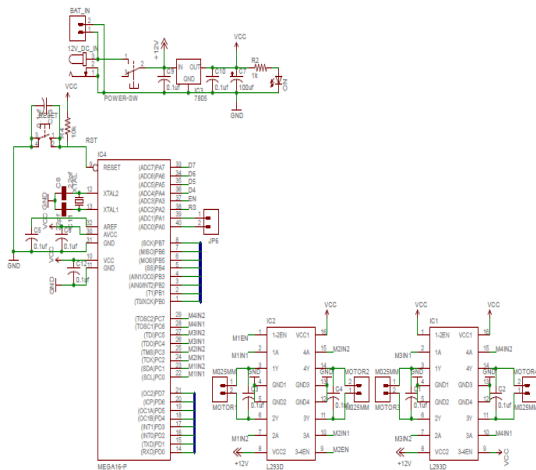

Fig.(C)Circuit Diagram

DC Motor

A DC motor is a device that converts electrical energy into mechanical energy. It works on the principle of Fleming’s left hand rule to determine the direction of force.

DC motors with built in gearing Arrangement is used in this work. It is because it is simple to control and have higher torque compared to servomotors. To use a DC motor, we need motor driver IC. To drive the motor simply connect the one wire to one of the driver terminals and the other to other terminal.



Voltage regulator 7805

7805 is a voltage regulator integrated circuit .It is a member of 78xx series of fixed linear voltage regulator IC’s. The voltage regulator IC maintains the output voltage at a constant value. The xx in 78xx indicates the fixed output voltage it is designed to provide . IC 7805 provides +5 regulated power supply . Capacitors of suitable value can be connected at input and output pins depending upon the respective voltage level.

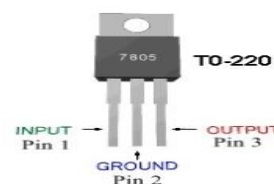

3. SYSTEM HARDWARE DESIGN

ATMEG16

The ATmega16 is a 8-bit microcontroller based on the AVR RISC architecture with low power consumption. ATmega16 is based on RISC(reduced instruction set computing) which can work on a maximum frequency of 16MHz. It’s a 40 pin microcontroller with 32 I/O lines which are divided into four 8 bit ports .It has speed of 1 million instruction per second(MIPS) with 131 instruction set (mostly one cycle) and have a operating voltage is between 4.5 to 5.5volts.



IC L293D

L293D is a typical motor driver IC that works on the concept of dual H-bridge i.e. it allows the voltage to be flow in either direction. It has four channels. Every motor requires two channels to control in both directions. It can switch the output voltage up to 4.5v to 36v.

IC L293D allows DC motor to drive both in forward and reverse direction. It is a 16 pin IC which can control a set of two DC motors simultaneously in any direction. It

means that you can control two DC motor with a single IC.L293D converts a low-current control signal to high-current signal which is used to drive the motor.

4. SOFTWARE DESIGN

WinAVR

Win AVR is a suite of executable, open source software development tools for the Atmel AVR series of RISC microprocessors hosted on the Windows platform. It includes the GNU GCC compiler for C and C++.

It contains all the tools for developing on the AVR. This includes avr-gcc (compiler), avrdude (programmer), avr-gdb (debugger), and Win AVR is used all over the world from accumulators sitting in more their damp basements, to schools, to commercial projects.

Win AVR TM include many open source projects. If you feel more innovative, volunteers are always welcome to help with fixing ailment, adding features, porting, writing information and many other tasks on a range of projects.

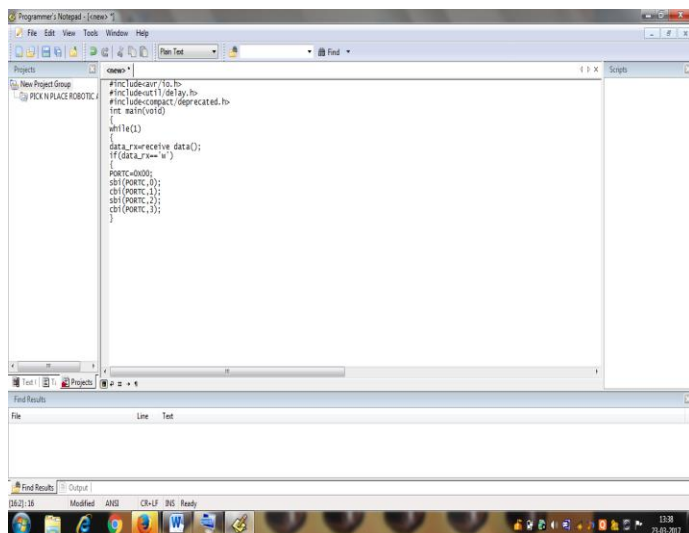

EAGLE

Eagle is a electronic design automation application used to make printed circuit board(PCB) layout.It stands for Easily applicable graphical layout editor.

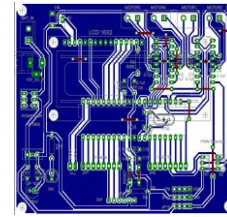

5. CONCLUSION

The aim of this work is the development of wireless control of a pick and place robot using Windows application .It is controlled by Laptop. The micro controller used is an Atmega16 and software named as WINAVR.

REFERENCES

- [1] Shaik Asma1 , J.Santhi2, P. Bala Murali Krishna3”Pick and Place Robotic Grasper using Wireless Communication”
- [2] Muhammad Jabir.N.K1, Neetha John2, Muhammad Fayas3, Midhun Mohan4 , Mithun Sajeev5 , Safwan.C.N6 “Wireless Control of Pick and Place Robotic Arm Using an Android Application” Vol. 4, Issue 4, April 2015
- [3] Guangming Song, Kaijian Yin, Yaoxin Zhou , Xiuzhen Cheng, "A Surveillance Robot with Hopping Capabilities for Home Security", IEEE Transactions on Consumer Electronics, Vol. 55, No. 4, Nov. 2009