

A Single Inductor Dual Buck Inverter

Alaka K¹, Jeena Joy², Reenu George³

¹PG Student[PE], Dept. of Electrical and Electronics Engineering, Mar Athanasius College of Engineering
Kothamangalam, Kerala, India

²Assistant Professor, Dept. of Electrical and Electronics Engineering, Mar Athanasius College of Engineering
Kothamangalam, Kerala, India

²Assistant Professor, Dept. of Electrical and Electronics Engineering, Mar Athanasius College of Engineering
Kothamangalam, Kerala, India

Abstract - In an inversion system, high reliability is one of the main targets pursuing. Some problems will threaten the reliability of the system, such as the shoot through issue and the failure of reverse recovery. The dual buck inverters can solve the above problems without adding dead time. A new topology of dual buck inverter with series connected diodes and a single inductor is presented here. The system retains the advantage of no reverse recovery of body diode. The inverter has just one filter inductor, which can make the volume and weight of the system decreased observably and improve the integration. The whole system is simulated in PSIM environment

Key Words: Body diode, MOSFET, PSIM, Reverse recovery, SPWM.

1. INTRODUCTION

The fast development of the clean energy power generation requires the inversion system, especially the inverters, to be more reliable. Yet shoot through problem of the power devices is a major threaten to the reliability. A traditional method to solve the shoot through issue is by setting dead time. However, the dead time will cause a distortion of the output current. Also, during the dead time, the current may flow through the body diode of the switch which can cause the failure of the reverse recovery [1]. For the purpose of solving the above problems, the dual buck topologies are proposed in a lot of research. By combining two unidirectional buck circuits, the dual buck inverters will not suffer threaten of shoot through problem and the freewheeling current will flow through the independent diodes which can solve the reverse recovery problem of the MOSFET's body diodes. However, the major drawback of the dual buck topologies is the magnetic utilization. Only half of the inductance is used in every working mode. And it will obviously increase the weight and volume of the system [2]-[4].

In order to improve the magnetic utilization of the dual buck inverter, a kind of single inductor dual buck topology was proposed in [5]. Compared with the traditional full

bridge inverter, two extra switches are applied in the proposed topology. The single inductor topology can make full use of the inductance, but the conducting loss is largely increased because four switches are flown through during the power delivering modes. This paper presents a kind of novel phase leg topology with series connected diodes and single inductor, to improve the reliability of the inverter, especially for the MOSFET inverter [6]. Applying the phase leg to the single phase inverter, an improved single inductor dual buck inverters are proposed in this paper. The novel topology has the following advantages. Firstly, retains the advantages of the traditional dual buck inverters, secondly, makes full use of the inductance, thirdly, the proposed inverter saves two switches compared to the traditional single inductor topology, which makes a lower conducting loss and a simpler controlling strategy. The simulation and experimental results have verified using PSIM.

2. CONFIGURATION OF OF DUAL BUCK INVERTER

The most attractive advantage of the dual buck topologies is the high reliability. Firstly, without adding the extra dead time, the dual buck topologies can solve the shoot through problem. Secondly, compared to the traditional H-bridge inverter, the current will not flow through the body diodes of the switches in the dual buck topologies which mean no reverse recovery problem exists in the MOSFET phase legs. Considering the above two aspects, the dual buck topologies can achieve high reliability without the shoot through and reverse recovery issues. However, the main drawback of the dual buck topologies is the low magnetic utilization. In each power delivering and freewheeling modes, the current only flow through half of the inductance, which means the other half of the inductance, is wasted in each working condition. The low utilization of the inductance makes the increasing of the weight and volume for the whole system. To solve this problem, a concept of single inductor dual buck full bridge inverter [7] is proposed. The circuit diagram of the inverter is shown in fig.1.

Comparing to the traditional dual buck full bridge inverter, the single inductor topology can save half of the inductance. And the novel topology retains the original advantages of

high reliability. Also, there is no need to add the dead time in the high frequency unipolar switching strategy. The inductance can be fully utilized in the single inductor inverter. However, a high level of conduction loss is the main drawback of the novel topology. During the power delivering mode, the current flows through four switches

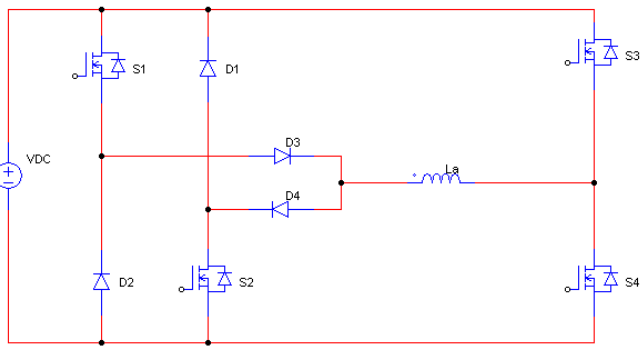

Fig -1: Dual buck inverter

which is a lot more than the traditional full bridge inverters. Besides, compared to the traditional dual buck inverter, the extra two switches are saved which make controlling strategy less complex. The control strategy is shown in fig.2. In the dual buck single inductor inverter, the current will flow through the body diodes of the series MOSFET switches which can cause the problem of reverse recovery.

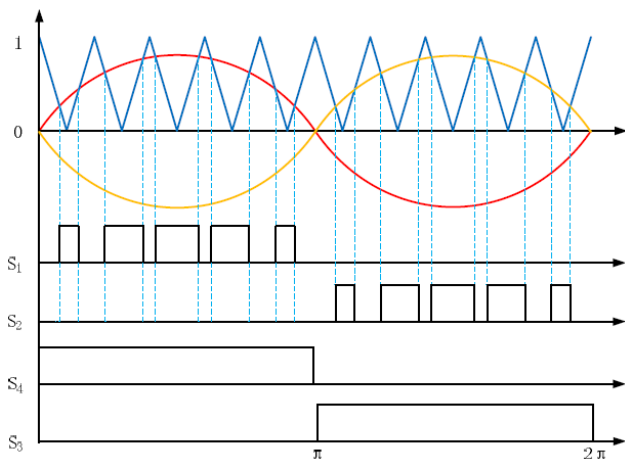

Fig -2: Control strategy

2. OPERATING PRINCIPLE

The operating principle can be well explained by means of four operating modes. The modes are selected based of the on period of the four switches. During each mode two switches are kept on. The different modes are as follows.

2.1. Mode 1

During positive half period, S_1 is modulated in high frequency, while S_4 is always ON. When S_1 and S_4 are on, the current flows through S_1 , D_3 , grid and S_4 successively. The circuit diagram of mode 1 is shown in fig.3.

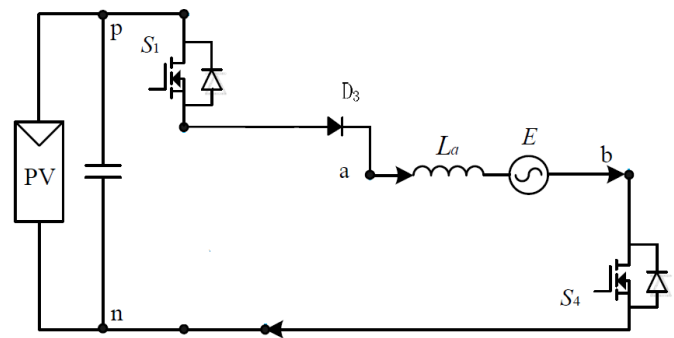

Fig -3: Mode 1

2.2. Mode 2

When S_1 is off, the current flows through D_2 , D_3 , grid and S_4 successively. As shown in fig. 4, in this freewheeling mode, the diode D_4 prevents the current from flowing through the body diode of S_2 , which avoid the failure of the MOSFET' s reverse recovery.

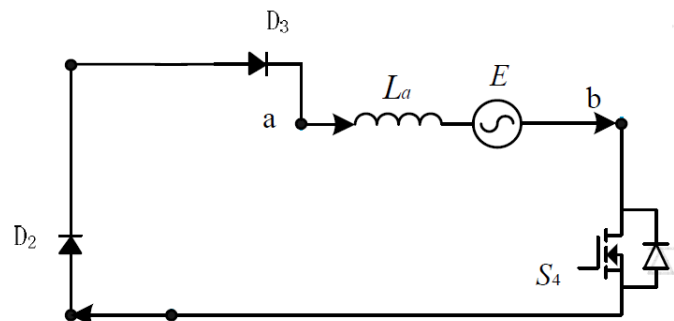

Fig -4: Mode 2

2.3. Mode 3

During negative half period, S_2 is modulated in high frequency, while S_3 is always on. When S_2 and S_3 are on, the current flows through S_3 , grid, D_4 and S_2 successively. The circuit diagram of mode 3 is shown in fig.5.

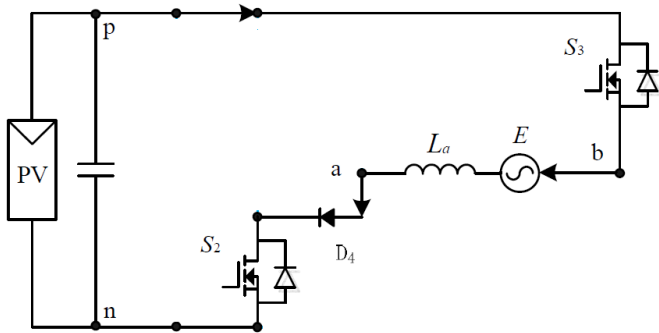

Fig -5: Mode 3

2.4. Mode 4

When S_2 is off, the current flows through S_3 , grid, D_4 and D_1 successively. As shown in fig. 6, in this freewheeling mode, the diode D_3 prevents the current from flowing through the body diode of S_1 , which can also avoid the failure of the MOSFET's reverse recovery.

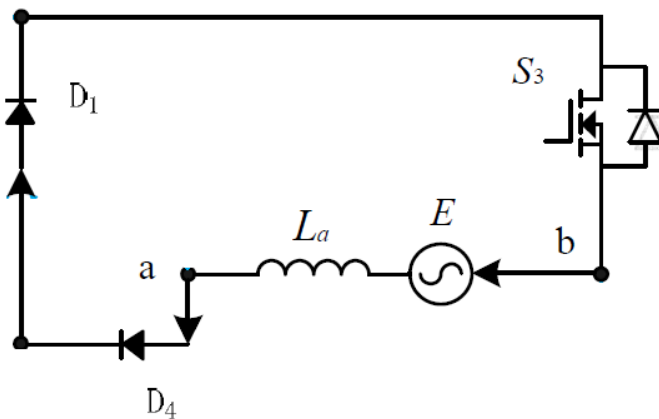

Fig -6: Mode 4

3. RESULT AND DISCUSSION

The simulation and experimental results are shown in this section. The proposed inverter is simulated in PSIM. The PSIM model is shown in fig.7. The DC voltage is 220V, and the grid voltage is 220V/50Hz. The switching frequency is 10 kHz. The output inductor is 2 mH.

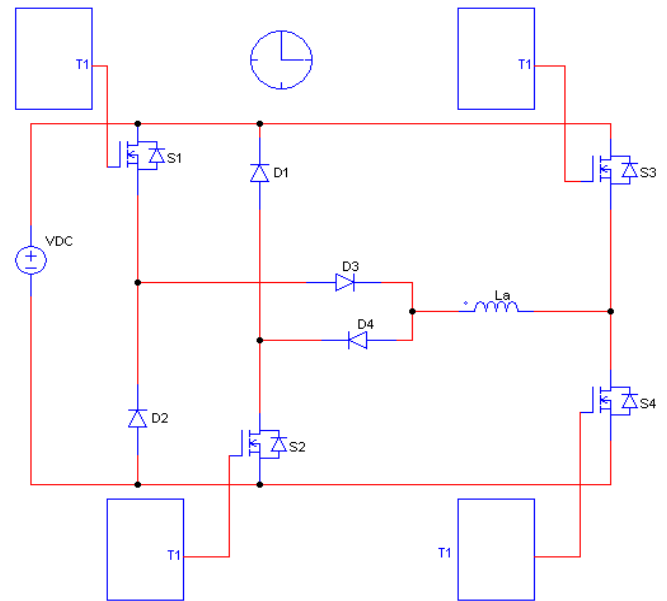

Fig -7: PSIM model of dual buck inverter

The control strategy involves uni polar SPWM for switches S_1 and S_2 and simple PWM for switches S_3 and S_4 . The gate pulses are as shown in fig.7. The input and output voltages obtained are shown in fig.8 and fig.9 respectively. The transformer less photovoltaic (PV) grid-connected system is an important application for the single phase inverter. However, in a transformerless PV system, the fluctuation of the common mode voltage will excite leakage current in the common mode path which may cause the safety problems and distort the output current.

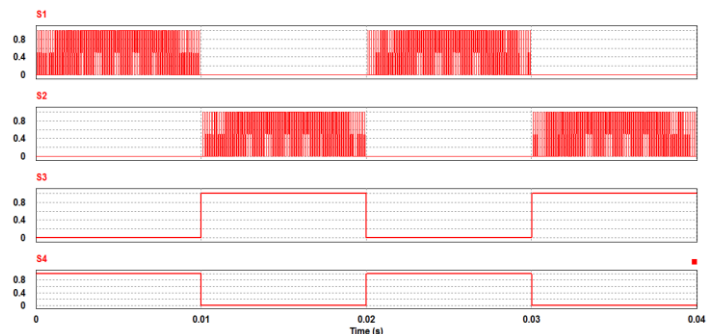

Fig -8: Gate pulses

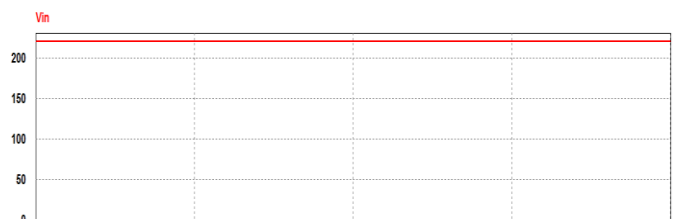

Fig -8: Input voltage of dual buck inverter

An input DC voltage of 220 V is applied at the input to obtain an inverter output of 220 V peak.

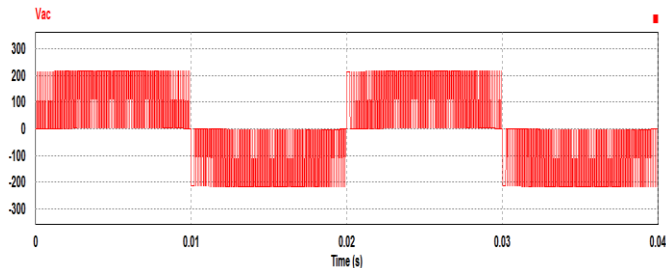

Fig -9: Output voltage of dual buck inverter

4. ANALYSIS OF DUAL BUCK INVERTER

The total loss of inverters includes the following. Switching and conduction loss of power switches and diodes, hysteresis loss, and copper loss of filter inductor. We can calculate each loss of power device. When the inductor current is continuous, the switching devices switch N_s times in a period, and the turn-on of the switch means the turn-off of freewheeling diode.

Since the switches work at power frequency, the impact of dead time is negligible. Thus, the impact of the shoot-through problem can be ignored. In addition, the proposed inverter also has independent freewheeling diodes with lower reverse recovery time, which can be used to reduce the reverse recovery loss. The passive components (namely, inductors and capacitors) play an important role in determining the volume and weight of inverter system. It can be seen that the proposed inverter just needs one inductor, which will further reduce the volume and weight. From the aforementioned analysis, the proposed inverter can be used in high reliability applications, such as aerospace, new energy power generation, smart power grids and high pressure, and high-power converting fields.

5. CONCLUSIONS

From the theoretical analysis and experimental result of the prototype, it is obtained that the inverter has high conversion efficiency and no reverse recovery of body diode. Compared with other dual buck inverters, the inverter has only one filter inductor; thus, the volume and weight of the system are observably decreased, and the integration is more improved. Since the diodes prevent the current flow through the body diodes of switches S_1 and S_2 the reverse recovery loss can be well reduced. In order to solve the main drawback of low magnetic utilization, a kind of phase leg topology is presented. By applying the novel phase leg to the full bridge inverter, the new topology maintains the high reliability of the traditional dual buck inverter and the magnetic utilization is largely improved. Also, compared to

the traditional single inductor dual buck inverter, the novel topology has the advantages in conducting loss and controlling complexity.

REFERENCES

- [1] Liwei Zhou, Feng Gao, "Dual Buck Inverter With Series Connected Diodes And Single Inductor", IEEE Trans.2016.
- [2] Y. S. Lee And Y. Y. Chiu, "A New High Efficiency Single Phase Transformer Less Pv Inverter," IEEE Trans. Ind. Electron., Vol. 49, 2005.
- [3] P. Xuwei And A. K. Rathore, "Novel Split Phase Dual Buck Half Bridge Inverter", IEEE Trans. Ind. Electron. , Vol. 61, No. 5, Pp. 2307-2315, May 2014.
- [4] D. Yu, Z. Le+ng, And X. Chen, "Decoupling Control Of Input Voltage Balance For Diode Clamped Dual Buck Three Level Inverter", IEEE Trans. Power Delivery, Vol.59, No.12, Pp.4657-4670, Dec.2012.
- [5] T. F. Wu, J. G. Yang, C. L. Kuo, And Y. C. Wu, "A Novel Flying Capacitor Dual Buck Three Level Inverter", IEEE Trans. Industrial Applications, Vol. 16, No.3, Pp. 1368-1376, March, 2014.
- [6] R. J. Wai, R. Y. Duan, And K. H. Jheng, "Single Inductor Dual Buck Full Bridge Inverter", IET Power Electron., Vol. 5, No. 2, Pp. 173-184, Feb. 2012.
- [7] M. Kwon, S. Oh, And S. Choi, "High Efficiency MOSFET Transformerless Inverter For Non Isolated Micro Inverter Application", IEEE Trans. Power Electron., Vol. 29, No. 4, Pp. 1659-1666, Apr. 2014.
- [8] D. Yu, A. Q. Hung, M.Wang, And S.M. Lukic, "High Efficiency Photovoltaic Inverter With Wide Range Power Factor Capability," In Proc. 27th Annu. IEEE Appl. Power Electron. Conf., 2012, Pp. 524-513.
- [9] L. Wang, Z. Wang, And H. Li, "Reliable Hysteresis Current Controlled Dual Buck Half Bridge Inverter," IEEE Trans. Power Electron., Vol. 27, No. 2, Pp. 891-904, Feb. 2012.
- [10] M. Kwon, S. Oh, And S. Choi, "Five Level Dual Buck Inverter With Neutral Point Clamp For Grid Connected PV Applications," IEEE Trans. Power Electron., Vol. 29, No. 4, Pp. 1659-1666, Apr. 2014.
- [11] Y. P. Hsieh, J. F. Chen, L. S. Yang, C. Y. W, And W. S. Liu, "Cascade Dual Buck Full Bridge Inverter With Hybrid PWM Technique," IEEE Trans. Ind. Electron., Vol. 61, No. 1, Pp. 210-222, Jan. 2014.
- [12] H. Feng, S. Renzhong, W. Huizhen, And Y. Yangguang, "Analysis And Calculation Of Inverter Power Loss," Trans. Proc. CSEE, Vol. No.15, Pp. 72-78, 2008.
- [13] S. V. Araujo, P. Zacharias, And R. Mallwitz, "Highly Efficient Single-Phase Transformerless Inverters For Grid-Connect Photo Voltaic Systems," IEEE Trans. Ind. Electron., Vol. 57, No. 9, Pp. 3118-3128, Sep. 2010.

- [14] M. Liu, F. Hong, And C. Wang, "Three-Level Dual Buck Inverter With Coupled-Inductance," In Proc. Asia-Pacific Power Energy Eng. Conf., Chengdu, China, Mar. 28-31, 2010, Pp. 1-4.