

# Seismic Effectiveness of Tuned Mass Damper - A Review

Shilpa Chandran.P<sup>1</sup>, Dr. CK Prasad Varma Thampan<sup>2</sup>

<sup>1</sup>PG Student, Department of Civil Engineering, NSS College of Engineering, Palakkad, India

<sup>2</sup>Professor, Department of Civil Engineering, NSS College of Engineering, Palakkad, India

\*\*\*

**Abstract** - In recent years, the tall buildings are very common, and they are flexible and having low damping capacity. Tall buildings vibrated under strong winds and earthquakes become uncomfortable for occupants. Therefore, various types of dampers are being developed at present to reduce the vibration in those structures. Recently dampers have become more popular for vibration control of structures, because of their safe, effective and economical design. This paper presents a review of literature related to the behavior of dampers on seismically affected structures. Tuned mass dampers (TMDs) are widely used to reduce vibrations in structures. A tuned mass damper is most reliable, most preferable and one of the simplest vibration control devices in existence today and these are widely installed in many structures around the world.

**Key Words:** Vibration Control, Free vibration characteristics, Optimum parameters, Tuned mass damper, Non Linear Time History Analysis.

## 1.INTRODUCTION

An earthquake is a natural phenomenon with violent shaking of the ground. Sudden movements of earth crust mostly due to tectonic movements caused vibrations of the earth's surface. With the rapid economic development and advanced technology, civil structures such as high-rise buildings, towers and long span bridges are designed with an additional flexibility, which lead to an increase in their susceptibility to external excitation. Two basic technologies are used to protect buildings from damaging earthquake effects. These are seismic dampers and base isolation devices. Seismic dampers are special devices introduced in the building to absorb the energy provided by the ground motion to the building. Dampers have become more popular recently for vibration control of structures, because of their safe, effective and economical design. The damper can be classified into various categories based on its functions or control system. The passive tuned mass damper (TMD) is found to be a simple, effective, inexpensive, and reliable means to suppress undesirable vibrations of structures

caused by harmonic or wind excitations. A Tuned mass damper (TMD) is a device consisting of a mass, and spring that is attached to a structure in order to reduce the dynamic response of the structure. The frequency of the damper is tuned to a particular structural frequency so that when that frequency is excited, the damper will resonate out of phase with the structural motion. Energy is dissipated by the damper inertia force acting on the structure. The Tuned Mass Damper (TMD) concept was first applied by Frahm in 1909 (Frahm, 1909) to reduce the rolling motion of ships as well as ship hull vibrations.

## 2.TUNED MASS DAMPERS

TMD is a passive damper. Some mass additional to the system mass is attached on it and is tuned to the frequency of the structure. The tuned mass dampers are generally installed at the top of a building. The installation requires large space for the damper. These dampers are generally suspended at the top and are tuned to one of the fundamental frequency of the building (generally first mode). The lightweight structure to overcome the inertia of a great mass due to presence of a tuned damper.

These dampers are suitable only when the structure responds significantly in one mode. The frequencies and amplitudes of the TMD and the structure should nearly match so that every time the wind pushes the building, the TMD creates an equal and opposite push on the building, keeping its horizontal displacement at or near zero. If their frequencies were significantly different, the TMD would create pushes that were out of sync with the pushes from the wind, and the building's motion would still be uncomfortable for the occupants. If their amplitudes were significantly different, the TMD would, for example, create pushes that were in sync with the pushes from the wind but not quite the same size and the building would still experience too much motion.

These dampers occupy large valuable space at the top of the building. Therefore instead of single TMD, multiple small TMD's along the height of the structure can be installed to effectively control the response of the structure. These TMD's can also take care of the response of the structure due to higher modes . If some of the TMD's cannot function properly then remaining TMD's will control the response of

the structure. The dampers are tuned along the height of the structure depending on the mode shapes of the structure.

The effectiveness of a TMD is dependent on the mass ratio (of the TMD to the structure itself), the ratio of the frequency of the TMD to the frequency of the structure, and the damping ratio of the TMD.

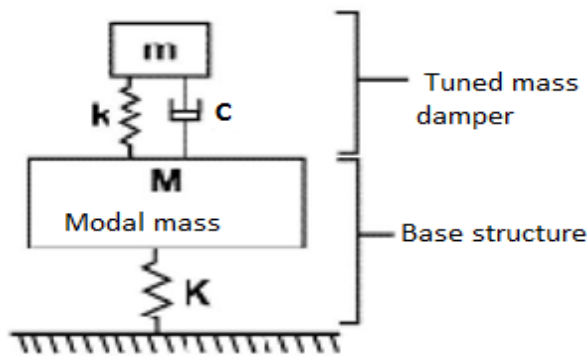

Fig -1: Base structure with TMD system



Fig -2: Tuned mass damper

### 3. LITERATURE REVIEW

Some literature reviewed about TMD in buildings, is presented in this section. There are number of works have been performed on seismic effectiveness of tuned mass damper by different scholars and researchers.

Chi-Chang Lin Jin-Min Ueng, Teng-Ching Huang(1999), "Seismic response reduction of irregular buildings using passive tuned mass dampers": This paper discussed about the practical considerations and vibration control effectiveness of passive tuned mass dampers (PTMDs). And they applied TMD for irregular buildings, modelled as multi-storey torsionally coupled shear buildings, under bi-directional horizontal earthquake excitations. Its moving direction and optimum installation location are determined from the controlled mode shape values. They calculated optimal system parameters of PTMD's by minimizing the

mean-square total modal displacement response ratio of controlled mode between the building with and without PTMD under the earthquake excitation from critical direction. The damper able to reduce the building responses effectively.

Osamu Yoshida et al (2002), "Experimental Verification of Torsional Response Control of Asymmetric Buildings Using MR Dampers": This paper proposes a semi active control system to reduce the coupled lateral and torsional motions in asymmetric buildings subjected to horizontal seismic excitations. Magnetorheological (MR) dampers are semiactive control devices in this. The asymmetric distribution of mass or stiffness, torsional motions, coupled with lateral responses in a structure, may be excited by lateral seismic loads. This behavior caused concentrated deformations in some of the columns of the structure, and amplifies accelerations at certain building floors.

Saidi, A D Mohammed *et al* (2007), "Optimum design for passive tuned mass dampers using viscoelastic materials": This conference paper forms part of a research project which aims to develop an innovative cost effective Tune Mass Damper (TMD) using viscoelastic materials. Generally, a TMD consists of a mass, spring, and dashpot which is attached to a floor to form a two-degree of freedom system. The paper provides a detailed methodology for estimating the required parameters for an optimum TMD for a given floor system. And also describes the process for estimating the equivalent viscous damping of a damper made of viscoelastic material. Finally, a new innovative prototype viscoelastic damper is presented along with associated preliminary results.

Thakur V M et al (2012) , "Seismic Analysis of Multistoried Building with TMD (Tuned Mass Damper)": This paper explains about TMD used is in the form of a soft story which is constructed at the top of the building. A six storied building with rectangular shape is considered and analysis is done by FE software SAP 2000 by using direct integration approach. TMDs with percentage masses 2% & 3% are used. Three different recorded time histories of past earthquakes are applied for the analysis. Comparison is done between the buildings with TMD and without TMD.

S.N. Khante, B.P.Nirwan (2013), "Mitigation of Response of Asymmetric Building using Passive Tuned Mass Damper": In this paper, response of asymmetric building with tuned mass damper to the selected ground motion is investigated. The parameters are eccentricity ratio of the superstructure ( $e_x/d$ ), uncoupled time period of the superstructure, ratio of

uncoupled torsional to lateral frequencies of the superstructure ( $\omega_\theta/\omega_x$ ), and mass ratio ( $m_d/m_s$ ). G+8 storey RCC asymmetric building is considered for analysis. Nonlinear time history analysis is carried out in SAP2000 software using El Centro earthquake record. The numerical results of the parametric study help in understanding the torsional behaviour of the building using passive tuned mass damper.

Balakrishna G.S et al (2014), "Seismic Analysis Of Building Using Two Types Of Passive Energy Dissipation Devices": In their conference paper presented about improve the seismic response of buildings in earthquake prone areas, with using passive energy absorbing devices. Here a 6 storeyed regular building is analysed using SAP2000 v14 with viscous damper (VFD), with Tuned Mass Dampers (TMD) and without any damping device. Tuned Mass Dampers with varying mass ratios of 2%, 3% and 5% was applied. Non-Linear Time History Analysis was carried out by applying the Bhuj earthquake.

Mariantonieta Gutierrez Soto, Hojjat Adeli (2014), "Optimum Tuning Parameters Of Tuned Mass Dampers For Vibration Control Of Irregular Highrise Building Structures": This study about, tall buildings with irregular in plan and elevation with complicated dynamic behavior. Vibration control of irregular highrise building structures using a recently developed tuned mass dampers (TMD). In this the bidirectional TMD (BTMD), is investigated. By checking the displacement, acceleration and base shear results, it is observed the performance of the BTMD in reducing the vibration responses is affected by the rigidity of the structure; it is more effective for taller and more flexible structures.

Alex Y. Tuan and G. Q. Shang (2014), "Vibration Control in a 101-Storey Building Using a Tuned Mass Damper": They investigate the effects of a TMD on the structural dynamic responses of Taipei 101 Tower. A detailed dynamic analysis is conducted to evaluate the behavior of the structure-TMD system, and the TMD in this building is materially effective in reducing the wind-induced vibration. A tuned mass damper (TMD) is a large, massive block, which is usually mounted on the top or near the top of a tall building. TMD's frequency can be tuned to match the predominant vibration frequency (usually the first modal frequency) of the main structure.

Mr. Ashish A. Mohite, Prof. G.R. Patil (2015), "Earthquake Analysis of Tall Building with Tuned Mass Damper": Conducted a software study of tuned mass damper (TMD) is placed on its top and through it to study its effects on Storey

drift, storey displacement and base shear and analysis with and without the tuned mass damper (TMD) in ETAB. Analysis of symmetrical moment resistance frame (MRF) 10th,12th,14th,16th,18th, and 21th storey three - dimensional model with tuned mass damper and without tuned mass damper by using software ETABS. These ideas were clearly explained in this paper.

Adrian Fredrick C. Dya et al (2015), "Seismic vulnerability assessment of soft story irregular buildings using pushover analysis": This study is used for first risk assessment of existing buildings with soft story. In this study, it is assumed that for each story, the properties and number of structural members is constant. The severity of the soft story is varied by increasing the height of the soft story. A static pushover analysis is used to determine the building performance under different irregularities. Due to the limitations of a static pushover analysis, the study only covers low-rise buildings as permitted by the NSCP( National Structural Code of the Philippines). Then they recognized that a dynamic time history is more suitable. The study has found that one of the primary concerns in vertical irregularities is the localization of seismic demand.

Vipin V. Halde et al (2015), "Review On Behavior Of Soft Storey In Building": They discussed in tall buildings soft storey construction considering typical features because of space occupancy considerations. Soft storey reduce the stiffness of the lateral load resisting system and a progressive collapse becomes unavoidable in a severe earthquake for such buildings. This storey containing the concrete column, they unable to provide adequate shear resistance, hence damage and collapse are most often observed in soft story buildings during the earthquake.

### 3. CONCLUSIONS

Recently use of seismic control systems has increased, but choosing best damper and installing it into a building is very important for reducing vibration in structures when subjected to seismic loading. Passive control systems are reliable and they doesn't require any external power. TMD is one of the best passive dampers.

### REFERENCES

- [1] Adrian Fredrick C. Dya , Andres Winston C. Oretaa (2015), "Seismic vulnerability assessment of soft story irregular buildings using pushover analysis", The 5th

- International Conference of Euro Asia Civil Engineering Forum.
- [2] Alex Y. Tuan, et al (2014), "Vibration Control in a 101-Storey Building Using a Tuned Mass Damper", Journal of Applied Science and Engineering, Vol. 17.
  - [3] Balakrishna G.S., Jini Jacob (2014), "Seismic Analysis Of Building Using Two Types Of Passive Energy Dissipation Devices", International Conference on Innovations in Civil Engineering 8th and 9th of May 2014.
  - [4] Chi-Chang Lin, Jin-Min Ueng, Teng-Ching Huang (1999), "Seismic response reduction of irregular buildings using passive tuned mass dampers", Engineering Structures, Elsevier.
  - [5] Ilaria, Annibale Luigi (2012), "Seismic Retrofitting of Irregular RC Buildings Using Active Tuned Mass Dampers" EACS 2012 – 5th European Conference on Structural Control.
  - [6] J. J. Aguirre and J. L. Almzan (2014), "optimum seismic design of Nonlinear asymmetric structures Controlled by large tuned mass Dampers", Tenth U.S. National Conference on Earthquake Engineering, Frontiers of Earthquake Engineering July 21-25.
  - [7] Osamu Yoshida, Shirley J. Dyke, Luca M. Giacomini and Kevin Z. Truman (2002), "Experimental Verification of Torsional Response Control of Asymmetric Buildings Using MR Dampers", Earthquake Engineering & Structural Dynamics, June 2002
  - [8] Saidi I, Mohammed A.D(2007), "Optimum design for passive tuned mass dampers using viscoelastic materials", Australian Earthquake Engineering Society Conference
  - [9] Thakur, V.M. and Pachpor (2012), "Seismic Analysis of Multi-storeyed Building with TMD (Tuned Mass Damper)", International Journal of Engineering Research and Applications, Vol. 2, Issue 1, 319-326.
  - [10] Vipin V. Halde and Aditi H. Deshmukh (2015), "Review On Behavior Of Soft Storey In Building", International Research Journal of Engineering and Technology (IRJET), e-ISSN: 2395 -0056 Volume: 02 Issue: 08 ,Nov-2015.