

Voice Recognition Based Automation System for Medical Applications and For Physically Challenged Patients

Sanu Kumar Das¹, Vitthal Rathod², Akhilesh Yadav.B³

¹Sanu Kumar Das, Dept. Of Electronics & Telecommunication, DYPCOE, Maharashtra, India

²Vitthal Rathod, Dept. Of Electronics & Telecommunication, DYPCOE, Maharashtra, India

³Akhilesh Yadav, Dept. Of Electronics & Telecommunication, DYPCOE, Maharashtra, India

Abstract – Voice is the most effective way of communication among human being. This, way of communication, can also be a useful interface to interact with machines. Therefore the dependency of voice recognition system has increased greatly in recent year. There are different methods to speech recognition like Hidden Markov Model (HMM), Hybrid Hidden Markov Model (ANN), etc.

This paper presents the prototype of voice recognition based automation system for the physically challenged people suffering from quadriplegia or paraplegia (who cannot move their body parts but can speak and listen) to control the various devices and can control the bed movement just by the voice commands according to his/her desire and comfort. The proposed model has a voice recognition model, Arduino uno microcontroller, relay circuit for LED & Buzzer and a motor for adjustable bed. The voice recognition model should be trained first & data should be stored before it can be used to recognize the commands. Once it recognized voice command the Arduino will control the respected load with the help of the relay circuit. The adjustable bed can be operated at different modes as per the user's requirement. The accuracy of voice recognition model is measured in different conditions. The results show the system can provide great help to the paralyzed people without any third person's assistances.

Key Words: Voice Recognition, ANN, Automation System for Paralyzed People, Arduino Uno, Motor, Buzzer, LED.

1. INTRODUCTION

Voice is the most effective and natural way to communicate. Human being also wants to have a similar natural, easy and effective way of communication with machines. Therefore they prefer voice as a media to interact with devices rather than using any other hectic interfaces like mouse and keyboards. But the voice is a complex phenomenon as the human vocal pitch and articulators, being the biological organs, are not under our control and not same every time. Voice Recognition or Automatic Speech Recognition (ASR) plays an important role in human being and machine interaction. Voice recognition uses different methodology to recognize the word and to convert voice signals into the sequence of words by means of an algorithm implemented as a computer program. Different techniques are used for this

process, like LPC, MFCC along with ANN. Voice recognition systems are capable of understanding of different languages and different of words under functional environment.

Voice signal provides two important types of information: [1] Content of Voice and [2] Identity of speaker.

Voice recognition automation system can be a used for various applications.[1] It can be used for home automation[2] It can be used for paralyzed patients to control multiple devices.[3] It has also many applications like telephone directory assistance, automatic voice translation into foreign languages.

2. VOICE RECOGNITION PROCESS

The process of voice recognition is complex and a hectic job. The figure 1 given below shows following steps involved in the process of voice recognition.

2.1 Voice Acquisition

Voice is the effective form of human communication. In this process, the voice of the speaker is received in the form of waveform. There is lots of software available which are used to record the voice of human being. In this we are storing the voice signal in the form of ".mat" The acoustic atmosphere and receiving equipment can have great effect on the voice generated. Sometime we have background noise or surrounding reverberation along with the voice signal which is unwanted and shouldn't process further.

2.2 Voice Pre-processing

In this step pre-processing block plays an important role in eliminating the unwanted signal. It finally improves the accuracy of voice recognition. The voice pre-processing normally includes filtering of noise, smoothing of signal, point to point detection, framing of signal, windowing of signal, & cancelling and removing of echo. It processed only original data further.

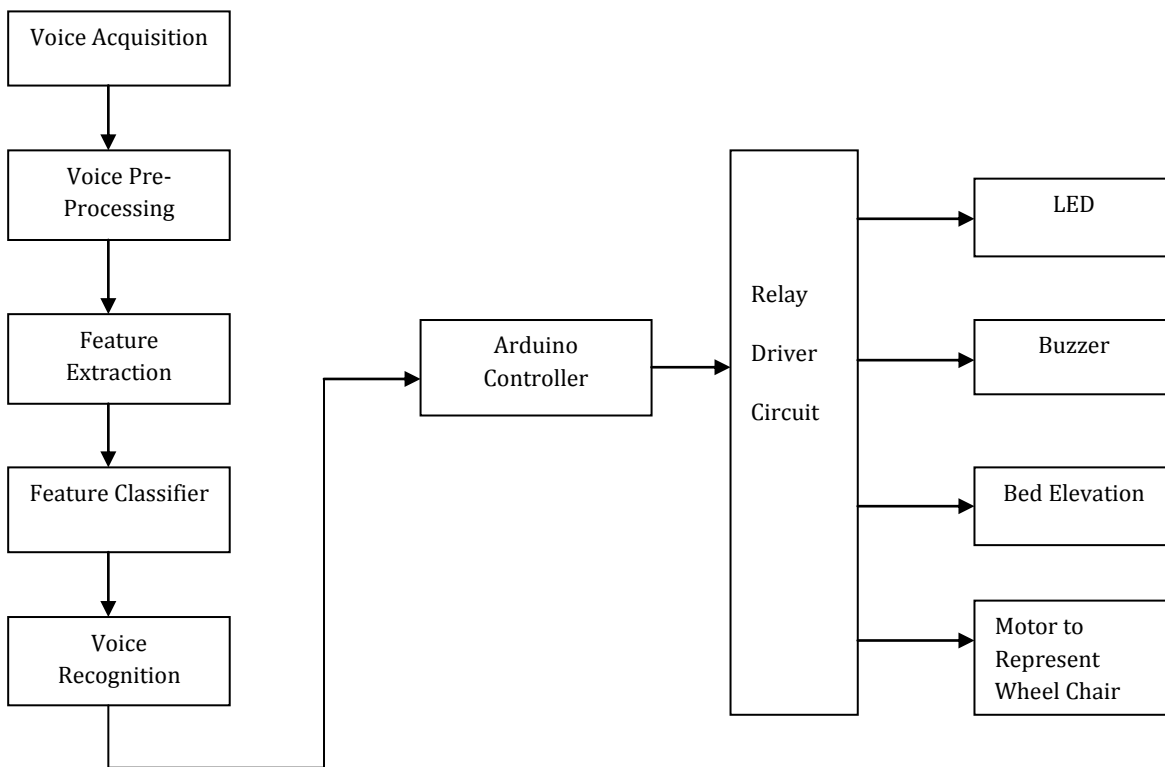

Fig. 1 Block Diagram of Voice Recognition Based Automation System

2.3 Feature Extraction

As we know that the voice differs from person-to-person. This is due to the fact that every person has different vocal cord which sounds differ. Theoretically, it is possible to recognize voice from the digitized waveform. But due to the large variation in voice signal, it is necessary to perform some feature extraction to reduce that variations and unwanted signal. There are different technologies are available for feature extraction, which are as follow. These technologies are also useful in other areas of voice processing

1. MFCC –Mel Frequency Cepstrum Coefficients (MFCC) is the most important method used in the process of feature extraction in voice recognition. As it has frequency domain features, therefore it's more accurate than time domain features .It represents the original cepstral of windowed short time signal which is expressed from Fast Fourier Transform (FFT). These coefficients are robust and dependable for the variations of speaker and the environment where operation is performed.

2. LPC –Linear Predictive Coding (LPC) is a tool which is widely used for medium or low bit rate coder. In this method digital signal is compressed for proper transmission and storage. Computation of parametric model based on least mean squared error theory is known as linear prediction (LP).

2.4 Feature Classification

The most common techniques which are used for feature classification are discussed below. This type of system has complex mathematical functions and they take out hidden information from the input signal.

HMM – Hidden Markov Model. (HMM) is the mostly used pattern recognition technique for voice recognition. HMM is a mathematical model which is signalized on the Markov Model and has a set of output distribution. In HMM method, voice is break down into smaller audible parts and these parts represent the state in the Hidden Markov Model. And according to the probabilities of transmission, there is a transmission from one state to another.

DTW –Dynamic Time Warping (DTW) technique compares the words with stored words. In this method, the time dimensions of the unknown words are changed until and unless they match with that of the stored word.

VQ –Vector Quantization (VQ) is a method in which the mapping of vector is done from a large vector space in a specific number of regions in that space. Each region is known as cluster and it can be shown by its centre which is known as a code-word.

3. ARTIFICIAL NEURAL NETWORK FROM THE VIEWPOINT OF VOICE RECOGNITION

3.1 What is Artificial Neural Network?

Artificial Neural Networks (ANN) is nothing but the structured electronic model which is based on neural structure of our brain. The human brain simply learns from the experiences. In the same way ANN trained the data and stored it for the next process.

ANN is a computer model which has the same architecture of human brain. They generally involve hundreds of quite simple processing units which are wired together in a complex communication network. Each simple processing unit actually represents a real neuron which transmits a new signal if it receives a strong signal from other connected unit.

3.2 Artificial Neuron

Artificial Neurons are the basic unit of Artificial Neural Network which reproduces the four basic function of biological neuron performed by human being brain. It is a mathematical function which is based on model of natural neuron of human brain. The given below figure shows the basic artificial neuron.

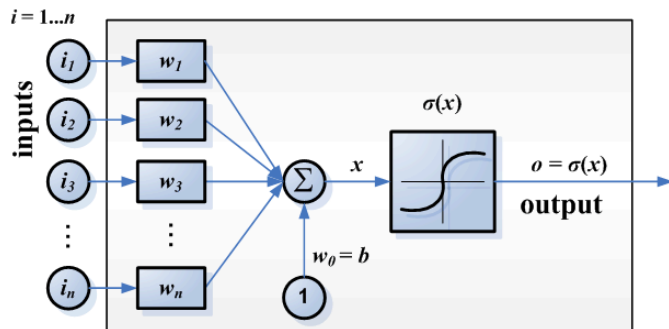

Fig. 2: Basic Artificial Neuron

In The above figure, various inputs are shown by the mathematical symbol, i.e. $i(n)$. Each inputs are multiplied by respected connecting weights $w(n)$.

Generally, these products are simply added and given to the transfer function to generate the desired results. The applications for example, text recognition and voice recognition are required to convert these real word inputs into discrete values. In the software system, these neurons are called as processing elements and it has many more capabilities than the basic artificial neuron which has described above.

4. SOFTWARE IMPLEMENTATION

To design the system we have written code on MATLAB. MATLAB is a fourth-generation high-level programming language and it provides an interactive environment for numerical computation, visualization and programming.

It provides matrix manipulations; plotting of functions and data; implementation of different algorithms; creation of user interfaces; it provides interfacing with programs which is written in other languages, including C, C++, Java, and

FORTRAN. It analyzes the data; it develops the algorithms; and creates required models and applications.

It has numerous inbuilt commands and mathematical functions that help user in mathematical calculations, and generating plots, it is also used for performing numerical methods.

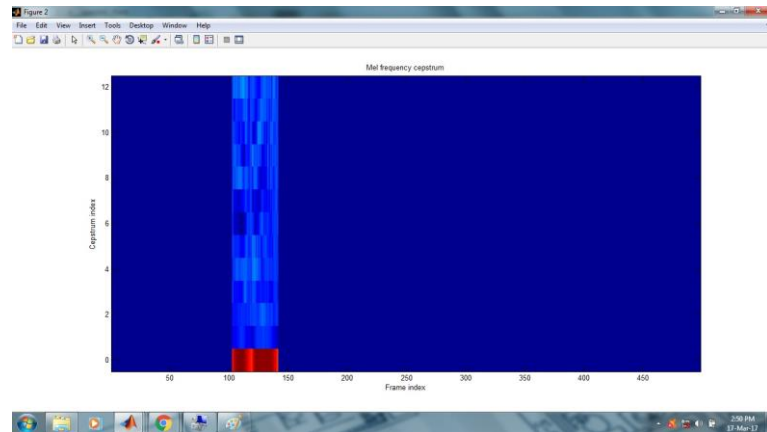

Fig 3. A Graph of Mel Frequency Cepstrum.

5. HARDWARE IMPLEMENTATION

The hardware implementation of proposed system is explained below.

5.1 Microphone and Voice Recognition Module

The microphone which is used to acquire voice signal and sends it to the voice recognition model is basically a collar type microphone with 3.5 mm jack. In this system we have used Elechouse voice recognition module v3 for the voice recognition process which has shown below in the Fig. The voice recognition module should be trained first and then it can be used to actually recognize the voice commands by speaker.

The voice input from the microphone is fed to the voice recognition model and here the input voice is compared with the trained voice commands which are stored previously, and if it is matched with stored and trained data then control action will take place in control circuit. The voice recognition model v3 can actually store up to 80 commands of 1400 to 1500ms each in its library and out of 80 commands only 7 commands can be used in recognizer for the process of recognition. Thus at a time only 7 commands are active and to add next 7 commands, it is necessary to clear the recognizer first.

The selected model has two ways of controlling the Serial Port, General Input Pins and General Output Pins. It has a recognition accuracy of 99% under suitable conditions.

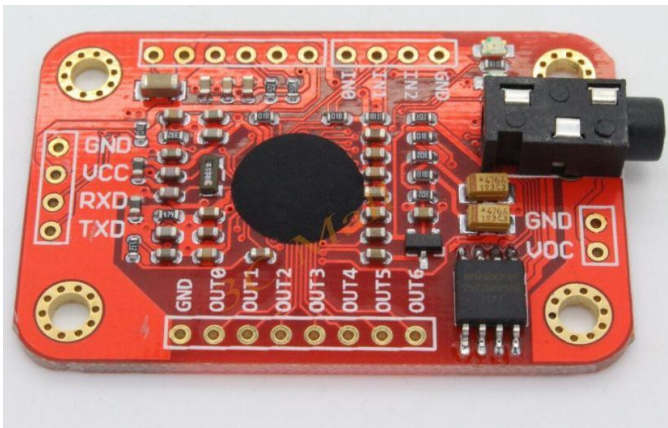

Fig. 4.Voice Recognition Module v3

5.2 Arduino Uno Microcontroller

The Microcontroller we are using for the proposed model is shown below in Fig. 5. The Arduino microcontroller provides an inexpensive, cheap, platform for students and professionals to create the devices that interact with respected environment using different types of sensors and actuators.

Arduino microcontroller has integrated development environment (IDE) which easily runs on a PC and it allows user to write programs for microcontroller in C or C++ language, which is easy and robust language compare to other language. The Arduino microcontroller board based on the AT mega 328. Following are the features of Arduino microcontroller. It has 14 digital input/output pins (Out of these 14 pins the 6 can be used as PWM outputs) and 6 is used for analog inputs.

It operates on 5V D.C and it has a clock speed of 16 MHz
 It has Input Voltage (recommended) 7-12V
 It has DC Current per I/O Pin 40 mA
 It has flash Memory of 32 KB of which 0.5 KB used by Boot loader

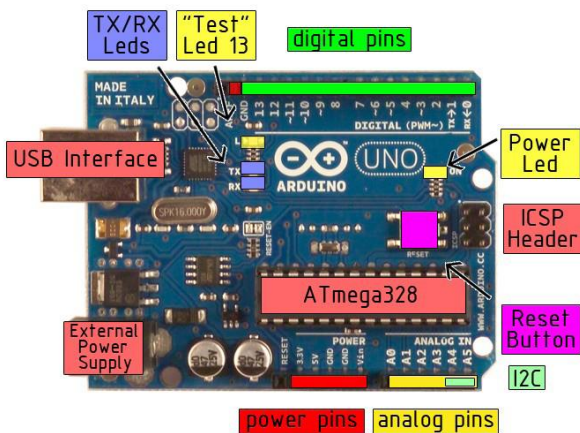

Fig. 5 Arduino Uno Microcontroller

5.3 Buzzer

In this model we are using buzzer as an indicator through which the respective person of the patient will come to the patient and check him, whenever buzzer makes sound. If the patient needs any help then by voice command he or she can turn on the buzzer for help.

A buzzer or beeper is an audio signaling device, which may be mechanical, electromechanical, or piezoelectric.

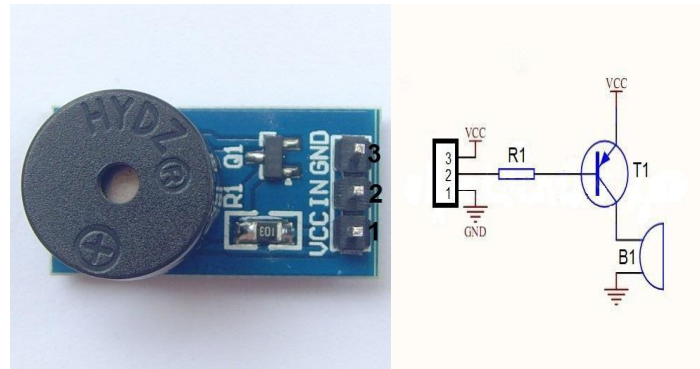

Fig. 6 5V Buzzer Module And Schematic Diagram.

5.3.1 Testing Results.

Below we have shown the testing result in which the output is the turning on and off of the buzzer every alternate second. The picture below shows the setup of our module and Arduino.

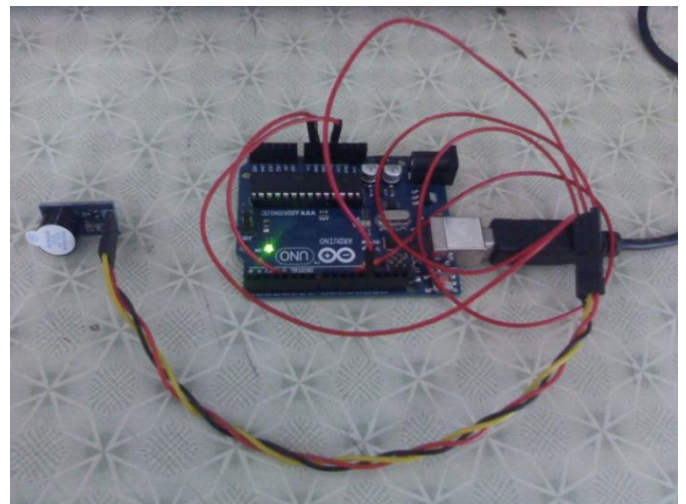

Fig.7 Showing Testing Result

5.4 Relay Circuit

To control the appliances generally relays are used with the Arduino microcontroller .The relays which we have used in the system are 5V-5 pin relay which is shown below in Fig. 8 Normally it remains in closed state. When the relay coils are energized the relay switches itself from normally closed state to normally open state due to the electromagnetic induction The normally open state (N.O) of relays are used in the automation system.

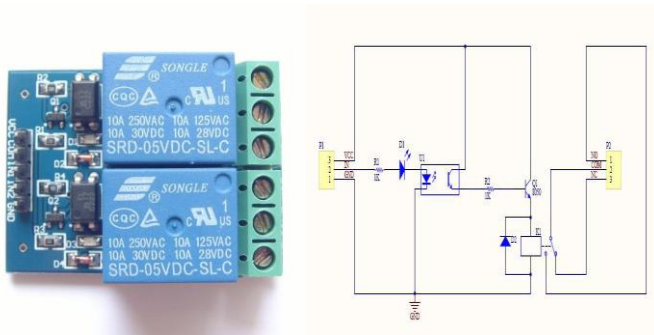

Fig.8 2 Channel 5V 10A Relay Model And Schematic Diagram

5.5 12V, 5A Power Supply

All electronic circuits work only on low dc voltage. Therefore It needs a power supply unit which can provide the desired voltage supply. The power supply which is required for this automation system are 5V for the relay circuit module and 12V 5A for the motor for bed elevation.

The requirement of 5V can be fulfilled from Arduino board itself, but for the 12V 5A supply we need additional power supply circuit. A Centre tap transformer of 15-0-15 V is used in this power supply. After that we use a bridge rectifier circuit which is used to converts the A.C to D.C.

The D.C which we get after conversion is not ripple free, therefore two capacitor C1of 3300 μ F and C2=0.33 μ F are used to remove ripple. To regulate the voltage for power supply LM338K Voltage regulator is used which gives regulated voltage of 12V and constant current of 5A.

The capacitor C3 of 100 μ F is used to remove the ripples from the output voltage and the diode D3 is used to protect the circuit when the capacitor C3 starts discharging, Fig. 9 given below shows the circuit diagram of the 12V, 5A power supply.

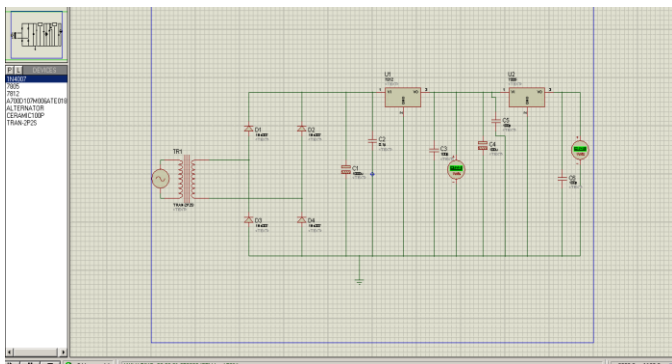
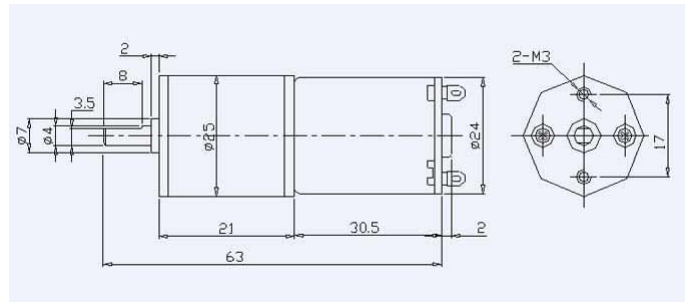

Fig.9 Circuit Diagram of Power Supply

6. DC MOTOR.

In this model we are using motor for bed elevation. We are using two motor which will elevate or down the bed according to the command. When the motor will run anti clockwise it will elevate the bed and when the motor will run clockwise the bed will be lowered. The motor which we are using here has following some feature. It has 12.0VDC, it has output speed of 200+ rotation per minute. The rotation output is CW/CCW. It is resistant to noise.



7. CONCLUSIONS

ANN is one of the most reliable techniques for the future computation. The model shows that it can be very useful in voice signal classification. It functions more like human brain than conventional computer logic.

ANN has better voice recognition rates than MFC, but it is complex to train algorithm and it is dynamically sensitive, which may cause problems. The future of this technology is very great and the only thing which has to improve is hardware development as ANN need faster hardware.

The voice recognition based automation system has built and implemented. The system is specifically designed for the patient suffering from paralysis and also for the aged people. A wooden adjustable bed fitted with motor is which is very economic and affordable.

The adjustable bed offers two elevation positions sleep position, and sitting position and according to patient's comfort he or she may choose the desired position by simply saying it, which will act as voice commands for the system.

The use of voice commands removes the necessity of remote controls and other electronic device and makes it simple to interact with the system to perform the function and control the devices.

Buzzer allows patient to notify the guardians whenever the patient is in need of help. The LED can be used for different purpose; it can be used to indicate multiple requirements by patients.

8. REFERENCES

- [1].T.Kirankumar and B. Bhavani, "A Sustainable Automated System for Elderly People Using Voice Recognition and Touch Screen Technology," International Journal of Science and Research (IJSR), vol. 2, pp. 265-267, August 2013.
- [2]. Rajesh Khanna Megalingam, Ramesh Nammily Nair, and Sai Manoj Prakhya, "Automated Voice based Home Navigation System for the Elderly and the Physically Challenged," in International Conference on Advanced Communication Technology, Seoul, pp. 603-608, February 2011.
- [3]. Arthi.J.E and M.Jagadeeswari, "Control of Electrical Appliances through Voice Commands," IOSR Journal of Electrical and Electronics Engineering, vol. 9, pp. 13-18, February 2014.
- [4].Parameshachari B D, Sawan Kumar Gopy, Gooneshwaree Hurry and Tulsirai T. Gopaul., "A Study on Smart Home Control System through Speech," International Journal of Computer Applications, vol. 69,pp. 30-39, May 2013.
- [5]. Norhafizah bt Aripin and M. B. Othman, "Voice Control of Home Appliances using Android," in International Conference on Electric Power, Electronic, Communication, Control, And Informatic Systems, Malang ,pp. 142-146, August 2014.
- [6] .S. M. Anamul Haque, S. M. Kamruzzaman and Md. Ashraful Islam1, "A System for Smart-Home Control of Appliances Based on Timer and Speech Interaction," in Proceedings of the 4th International Conference on

9. BIOGRAPHIES



Sanu Kumar Das is a student of Dr.D.Y.Patil College of Engineering, currently pursuing his B.E in Electronics & Telecommunication. His areas of interest are DSP, Signal & System, and Digital Communication System.



Akhilesh Yadav. B is a student of Dr.D.Y.Patil College of Engineering, currently pursuing his B.E in Electronics & Telecommunication. His areas of interest are Digital Control System, Embedded Systems etc.



Vitthal Rathod is a student of Dr.D.Y.Patil College of Engineering, currently pursuing his B.E in Electronics & Telecommunication. His areas of interest are Power Electronics and Drives, Digital Control, ANN & Fuzzy Logic Applications etc.