

PIC Microcontroller based baby incubator using sensors

Dhruvkumar Pandya¹, Jay Parmar², Apurva Patel³

¹ Student IV Year B.E, Dept. of EE, Vadodara Institute of Engineering, Kotambi, Gujarat, India.

² Student IV Year B.E, Dept. of EE, Vadodara Institute of Engineering, Kotambi, Gujarat, India.

³ Student IV Year B.E, Dept. of EE, Vadodara Institute of Engineering, Kotambi, Gujarat, India.

-----***-----

Abstract - There are 16 million babies are born too early every year. The rate of preterm birth range from 6%-20% of babies born across 184 countries according to WHO. Almost 4 million children die each year due to preterm birth. In the first month, one million die on the first day low birth weight (LBW) is the greatest risk of the new born babies. The countries with the greatest numbers of preterm births are in India-35,19,100; China- 11,72,300,Pakistan- 7,48,100,U.S- 5,17,400 and Brazil-2,79,300.The microcontroller based baby incubator help to all peoples. Cost of this project is very low. So, everyone which belongs to economical backward also use this. Today baby incubator used in all big hospital. This project not only used for monitoring and controlling the temperature but also provide of advantages such as controlling humidity and monitoring the heart beat and respiration.

Key Words: Microcontroller, Temperature sensor, Humidity sensor, Heart beat sensor, Respiration sensor, GSM modems, Baby incubator, switching circuit, etc.

1. INTRODUCTION

This project is design to control the temperature and humidity. It is use to control the temperature and humidity of a small environment in a baby incubator. A baby incubator system is use for the Preterm birth babies, new born babies and sick babies. It provides a safe and clean environment, with fresh air, clean and sterile ambient condition for the babies. In baby incubator provide a homogeneous and stable temperature, a relative humidity level, heart beat and repatriation sense and concentration that is need especially for intensive care of the preterm baby and full term baby. Most of the baby incubator's are made up of using microprocessors.

1.1 Incubator Heating System

For this an automatic incubator comprises a chamber surrounded by a water jacket and insulation with temperature and gas level sensors, a gas injection and separate water jacket and air heaters.

In incubator microprocessor is use for the controller temperature, humidity and gas concentration. Fan is provided to circulate air and distribute heat in incubator. In incubator manual set temperature and humidity used. Temperature, humidity and gas level displays, high and low temperature and gas indicators and low water indicator.

Figure 1 Incubator Heating System

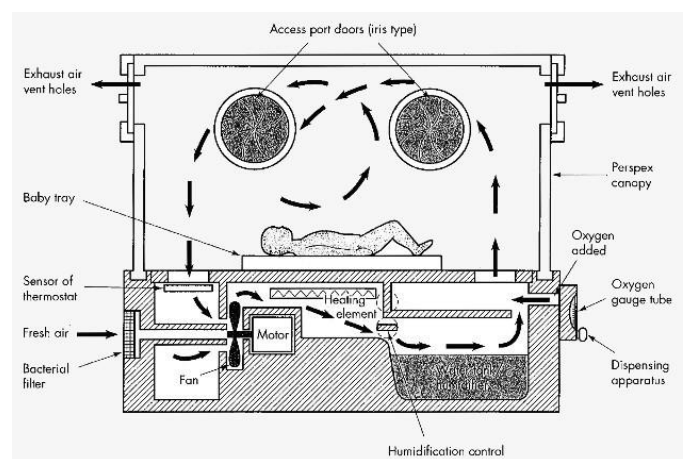

The basic operation of the circuit is monitoring the temperature and humidity within the incubator shell. The temperature sensor will detect the temperature and send the single to the microprocessor for further action. If the temperature level is high, then the microprocessor will send single to the temperature injector to open the valve. Some time microprocessor send single to outlet the air flow in incubator. In incubator the temperature level too low, the microprocessor send the single to the fan, and fan will be stopped. High and low temperatures level detection, the red color light blink and the warning by the alarm system.

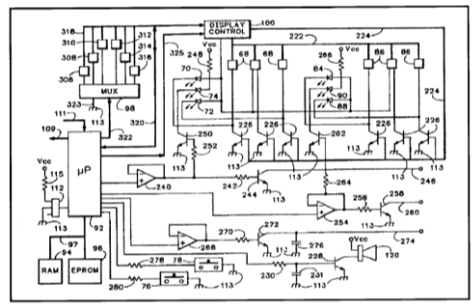

Figure 2 Control circuit for incubator using Microprocessor

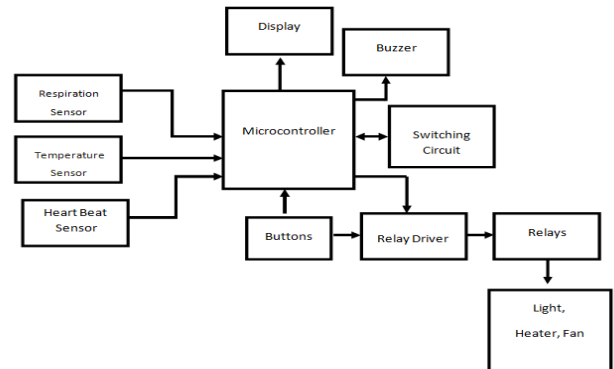

Figure 3 Block Diagram

2. Block Diagram and Description

Microcontroller: It will Read all information from sensors and compare it with Set Levels. If any problem it will send SMS to Operator and Buzzer will Sound. It Regularly Log Data in Computer for Monitoring of Patient.

LCD: it is used for Display Sensor information and System Running Status.

Buttons: These are used for change the Set Level of Sensing Information.

Temp. & Humidity Sensor: we have selected combine Module Named DHT22. It is Purely Digital. It communicates with MCU by one wire. It directly gives digit data so we don't have to convert the data, we just have to get it and print it.

Heart Beat Sensor: In our top of our finger Blood Circulation is changed as per our Heart Beats. So it changes it Density accordingly Heart Beat and it sense by the IR Light.

Respiration Sensor: As we Breath our Chest is Changes its state. If we attach Flex Sensor then we can get digital output from it. So we will use Flex Sensor.

Switching Circuit: We need Connection of Computer and GSM Modem. Both need UART Module to Communicate with MCU. Our MCU have only one UART Module. So we have connected Switching Circuit by which we can connect both simultaneously when it need.

Respiration Sensor: As we Breath our Chest is Changes its state. If we attach Flex Sensor then we can get digital output from it. So we will use Flex Sensor.

Switching Circuit: We need Connection of Computer and GSM Modem. Both need UART Module to Communicate with MCU. Our MCU have only one UART Module. So we have connected Switching Circuit by which we can connect both simultaneously when it need.

Computer: It is used for Logging Data with time and Sensor information in Real Time.

GSM Modem (SIM300): this is used for sending SMS to operator about emergency in incubator.

Relay Driver: Relay can't be connecting directly to MCU to save MCU from Short Circuit and High Current. So to provide isolation we need Relay Driver. We have used ULN2003. It consists of 7 Relay Driver modules inside a single chip.

Buzzer: it is used for generate sound at the time of emergency.

Relays: these are used for switching the Lights by electrical signal from MCU.

3. RELATED WORK

I. Temperature Sensor & Humidity Sensor

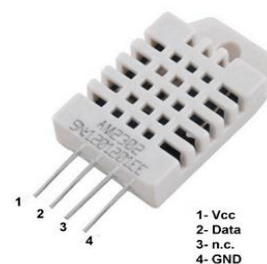

Fig 4: Temperature Sensor & Humidity Sensor

The DHT22 is a basic, low-cost digital temperature and humidity sensor. In DHT22 Polymer capacitor Sensing element is used. It is simple to use. Temperature range is -40° to 90° Celsius and humidity range is 0 to 100%RH. It is sensing period is 2 second. The second pin is data pin it is connect to the microcontroller. Third is NC (Not connected)

pin and fourth pin is show in fig this pin is ground pin. DHT22 sensor is give data after every 3 second.

This sensor is more precise, more accurate and works in a bigger range of temperature/humidity.

It's larger and more expensive. Temperature sensor connected to the microcontroller. In baby incubator DHT22 detect temperature more then 34 Celsius, so cooling fan will be switched on automatically and bulb is switch off. In case temperature is decrease to the 34⁰ Celsius so bulb is automatically switch on. Temperature sensor maintains the 34⁰ to 35.5⁰ Celsius temperature in baby incubator. DHT 22 also maintain temperature and humidity in incubator.

Below table shows relation between weight and range of temperature.

Hours & Weight	Starting temperature	Range of temperature
0 to 6 hours		
1200g	35 °c	34 °c To 35.5 °c
1200g - 1500g	34 °c	33.9 °c To 34.2 °c
1500g - 2500g	33 °c	32.8 °c To 33.8 °c
Over 2500(greater than 36 weeks)	32 °c	32 °c To 33.8 °c
6 to 12 hours		
1200g	35 °c	34 °c To 35.4 °c
1200g - 1500g	34 °c	33.5 °c To 34.3 °c
1500g - 2500g	33 °c	32.7 °c To 33.8 °c
Over 2500(greater than 36 weeks)	32 °c	31.4 °c To 33.8 °c
12 to 24 hours		
1200g	34 °c	34 °c To 35.4 °c
1200g - 1500g	33 °c	33.3 °c To 34.3 °c
1500g - 2500g	32 °c	31.8 °c To 33.8 °c
Over 2500(greater than 36 weeks)	32 °c	31.0 °c To 33.7 °c
24 to 48 hours		
1200g	34 °c	34 °c To 35 °c
1200g - 1500g	33 °c	33 °c To 34.2 °c
1500g - 2500g	32 °c	31.4 °c To 33.5 °c
Over 2500(greater than 36 weeks)	32 °c	30.5 °c To 33.3

Table 1

II. Heart beat sensor

Heartbeat sensor is developed by us. In heartbeat sensor two Operational amplifiers is use. In top of our finger Blood Circulation is changed as per our Heart Beats. So it changes its Density accordingly Heart Beat. If we apply IR signal to our finger it reflect different IR light as its density. But this change is Very small. So we have connected 2 Non -inverting Amplifier with Gain of 101. So we will get Pulses of Our Heart Beat.

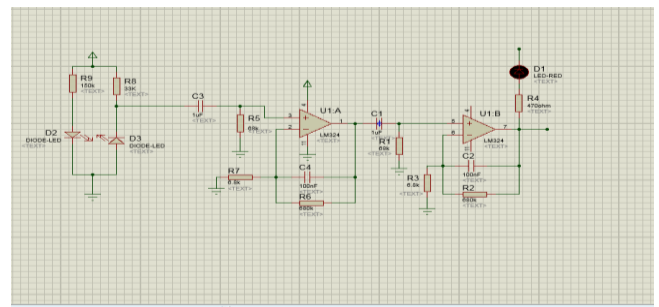

Fig 5: circuit diagram of Heart beat sensor

III. Respiration sensor

Respiration sensor is developes by us. In this sensor flex sensor is use. Flex sensor work based on resistive carbon element. Flex sensor is variable printed resister. Flex Sensors use for the P5 gaming glove, and the below applications:

Automotive controls, Medical devices, Industrial controls, Computer peripherals, Fitness products, Musical instruments.

In flex sensor normal condition the normal resistance value but it is band 45° increased resistance value. Further band 90° more increased resistance value.

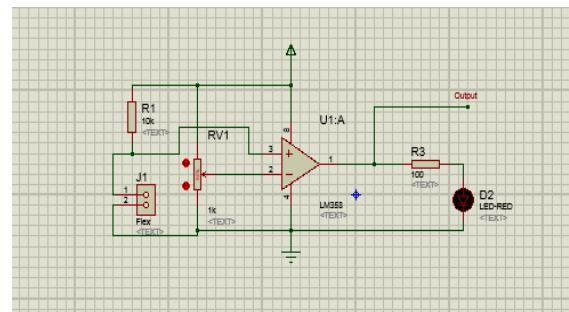

Fig 6 Circuit Diagram of Respiration sensor

IV. GSM Modem (SIM 300)

The GSM modem can accept any GSM network and operated by SIM card. Switching circuit is use to communicate and develop embedded application. Switching circuit developed by us. In switching circuit we can use 7432 and 7408. It is developed by very easy. The modem is connected to directly pc serial port and PIC microcontroller pin RX/TX. In case baby heartbeat pulse is reduced the rated pulse in baby incubator it sends the message to screen or mobile; If breathing rate is reduced to the rated value so, GSM modem sends to the mobile and screen.

Age	Heartbeat Rate (beat/min)
Premature baby	120-170
In 0 - 3 months	100-150
In 3 - 6 months	90-120
In 6 - 12 months	80-120
In 1-3 year	70-110
In 3 - 6 year	65-110
In 6 - 12 year	60-95
12 year above	55-85

Table 2

V. PIC Microcontroller

The microcontrollers played revolutionary role in embedded industry and other place after the invention of 89c51. The steady and progressive research in this field gave the hospital, industry and other place more efficient, high-performance and low-power consumption microcontrollers. The AVR, PIC and Ardiono are the prime examples.

Full form of PIC Microcontroller Peripheral Interface controller, it is one of the advanced microcontrollers developed by microchip technologies. This microcontroller is widely using in modern electronics applications. This controller is more advanced than normal microcontroller like 89c51.

Temperature sensor, Humidity sensor, Flex sensor, and Heartbeat sensor is used. There are many functions are involved such as cooling, heating, pulse rating, display all readings, etc.

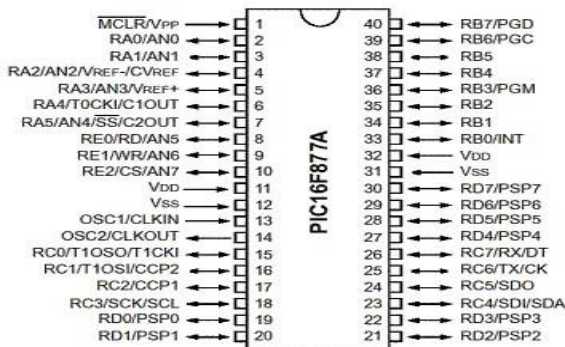

Fig 7

PIC controller is 8 bit microcontroller. In PIC16F877A is 40 pin microcontroller device. The PIC16F877A features 256 bytes of EEPROM data memory, 2 Comparators, 8 channels of 10 -bit Analog- to-Digital (A/D) converter, 2 capture/compare/PWM functions, the synchronous serial port can be configured as either 3 -wire Serial Peripheral Interface (SPI™) or the 2-wire Inter-Integrated Circuit (I²C™) bus and a Universal Asynchronous Receiver Transmitter (USART), self-programming.

VI. Cooling Fan

Cooling fans come in all shapes and sizes as well as voltages, airflow and case size. It is important to know the specific type of fan your CPU or electronic component requires as fans. In the baby incubator the temperature or humidity is increases to the rated value the fan is on condition otherwise fan is off condition. A relay circuit is used for the switching the voltage from 5V to 12V, which is the Voltage required to run the Fan.

5. CIRCUIT DIAGRAM

The given circuit diagram shows interfacing between all components of this project. Here PIC Microcontroller is use to control the all sensors in the baby incubator.

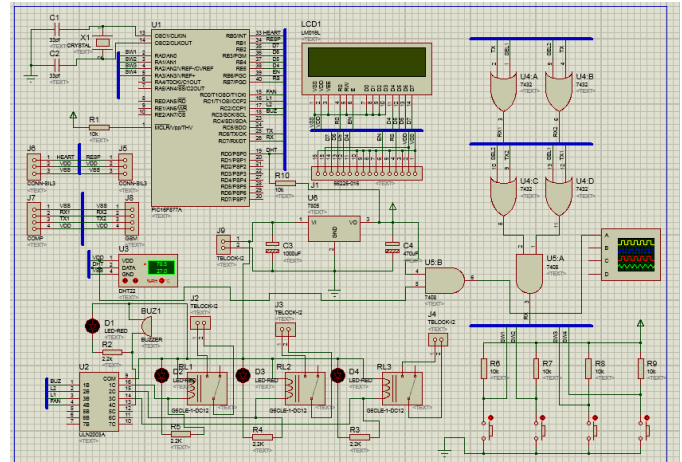

Fig 8 Circuit Diagram

6. RESULTS

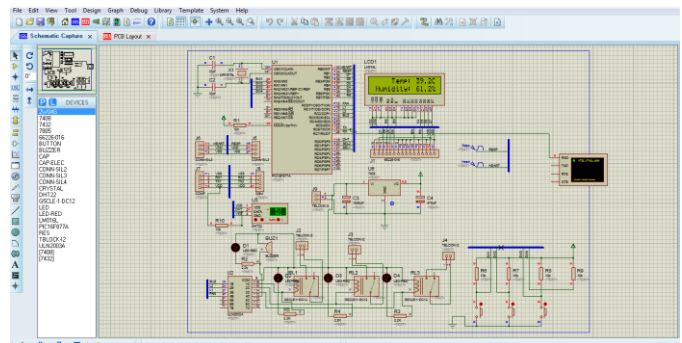

Fig 9 Result 1

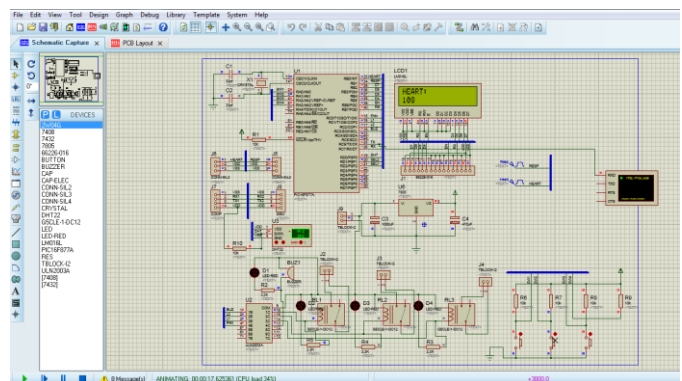

Fig 10 Result 2

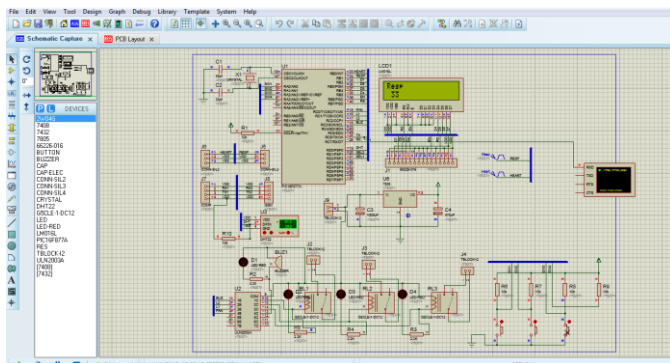

Fig 11 Result 3

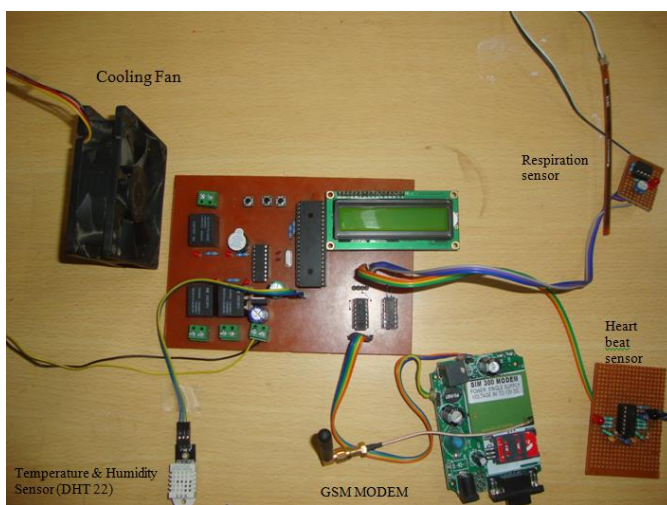

Fig 12

7. CONCLUSIONS

The project is designed keeping in mind the medical conditions available in rural areas. This Equipment can be effectively used by technicians in a small health care centre. It can be a life saving machine for premature baby as well as low birth weight babies. The components can be easily fixed. The chamber is sufficient enough to accommodate the baby comfortably. The temperature and humidity of the system can be easily understood. This project is simple and efficient in maintaining the temperature and humidity of the in the incubator irrespective of the outside temperature and humidity. It is low cost design.

Above figure shows the Simulation results of complete circuit carried out using Proteus software. The results obtained from the PIC16F877A microcontroller interfaced with one DHT22 temperature sensors and humidity sensor. The LCD is used to monitor the sensor readings. If the temperature in incubator increased above 37⁰c then cooling fan is on condition and heating bulb is off condition, similarly if temperature decreases then heating bulb is on condition and cooling fan is off condition. Also

heartbeat and respiration ratings are continuously display on LCD.

REFERENCES

- [1] Med A.Z.,Elyes F., and Abdelkader M., "American Journal of Engineering and Applied Sciences", Application of Adaptive Predictive Control to a Newborn Incubator, 4 (2): 235-243, ISSN 1941-7020, 2011.
- [2] Microcontroller Based Baby Incubator Using Sensors, M.Suruthi, S.Suma, International Journal of Innovative Research in Science, Engineering and Technology, Vol. 4, Issue 12, December 2015, ISSN 2319-8753.
- [3] PIC Microcontroller based Efficient Baby Incubator, International Journal of Advanced Research in Electrical, Electronics and Instrumentation Engineering, Vol. 4, Issue 2, February 2015, ISSN (Online): 2278 – 8875.

BIOGRAPHIES



Dhruvkumar Pandya is currently pursuing Bachelor of engineering in electrical field from Vadodara Institute of Engineering, Kotambi, Vadodara, Gujarat.



Jay Parmar is currently pursuing Bachelor of engineering in electrical field from Vadodara Institute of Engineering, Kotambi, Vadodara, Gujarat.



Apurva Patel is currently pursuing Bachelor of engineering in electrical field from Vadodara Institute of Engineering, Kotambi, Vadodara, Gujarat.