

ROBO LEG

Nikeeta Thorat¹, Priyanka Shinge², Akshata Kadam³, Prof. Poonam Bhosale⁴

^{1,2,3}B.E. Dept. of Electronics & Telecommunication

⁴Assistant Professor Dept. of Electronics & Telecommunication

Sanjeevan Engineering and Technology Institute, Panhala, Maharashtra, India

Abstract - This paper describes an information related with walking comfortably and safely for old age persons and paralyzed persons walk. It can be used in daily life to support the walking ability of physically challenged persons. Instead of taking six degree of freedom for robot we will have three degree of freedom (Hip-1, Knee-1, Ankle-1). By using these three degrees of freedom structure we can also overcome the cost and complexity of these project. It directly inspired from human walking analysis and muscles mechanism and control. Able to walk in various environments such as up slope, down slopes and some obstacle.

Key Words: Paraplegia, walking support, humanoid robot

1. INTRODUCTION

A robot leg is a mechanical leg and able to perform the same functions as that of human leg. It is typically programmed to execute similar function as that of human leg perform in their daily life. It is also called as prosthetic leg; however, the robotic leg can be controlled by electrically or by mechanically. To have robotic leg exhibit behavior of the human leg.

People have rigidity, relaxation, involuntary contraction of the muscles and post-polio syndrome. Even if people do not suffer from these physical problem, aging bring various trouble on his/her mortality. Most of the people have the problem in there lower limb due to this symptoms or aging are unable to walk and bed ridden all day long with worst. Moreover, these depress the patient's feelings and lose his/her the life of living. To relieve these problems and support the patient life, it is also important and provides a safe and convenient transportation device.

2. BLOCK DIAGRAM

The main block is microcontroller 89S52. It contains 256*8-bit internal RAM. Battery gives the essential power supply required to the microcontroller. Output voltage of battery is 6V and output current is 4.5 mill ampere. To run the robo leg total three keys are used in this project. The first key give forward

direction motion, second key gives reverse motion and third one gives the automatic mode that is both forward and reverse motion having some amount of delay (30 seconds).



Fig -1: Existing Model



Fig -2: Modified Model

Motor relay driver circuit consist of ULN2003 IC which is used to drive the relay. Relays are used because only low power signal is used to control the circuit. In this project four relays are used to drive two motors that is two relays for each motor. Each relay gives output voltage of 6V and each motor require input voltage of 12V respectively. Here two motors are used one is at hip joint and another is at knee joint. These two motors are DC motors. In DC motor the coil of wire which carries the current generated an electromagnetic field and by

switching on or off the current in coil we can switch the direction of magnetic field. So, we can able to do movement of our robo leg. LCD display is used 16*2 type. The function of LCD display is to display the status of event performed by the circuit.

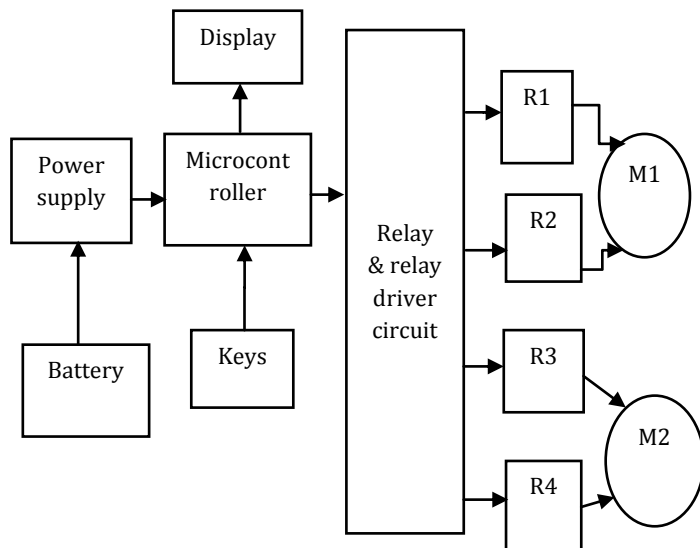
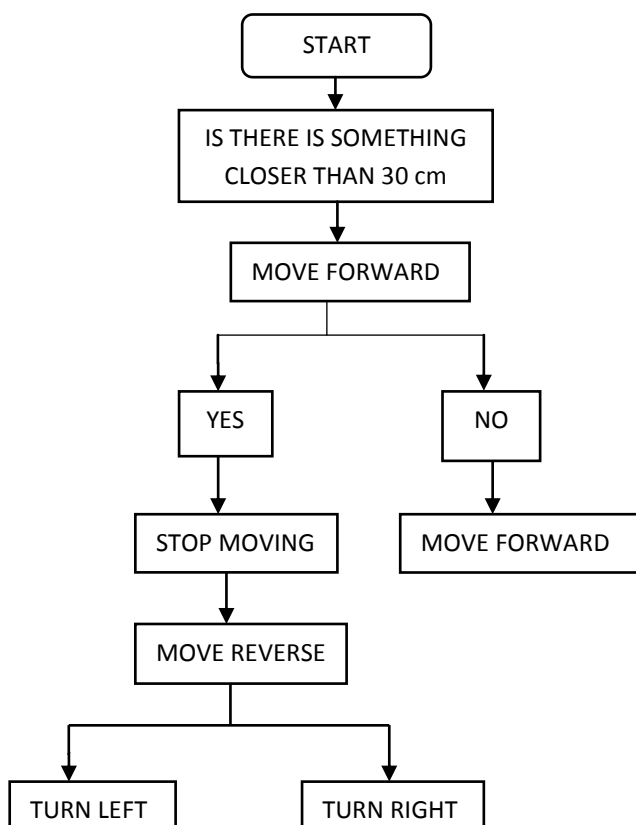

Fig -3: Block Diagram

3. FLOW CHART



4. DESCRIPTION

Microcontroller 89s52 is central controlling unit. No need of any A to D converter. 8051 compatible 89s52 IC is sufficient for working of this project. 16*2 display is interfaced to the microcontroller and power supply is achieved with the help of battery of 6V and 4.5Ah.

To get 5V regulated voltage, voltage regulator 7805 is used. Microcontroller need +5V DC voltage so we use low cost linear regulator National Semiconductor LM7805. It requires input voltage at least 7.5V to guarantee of the regulation. So, the unregulated power supply should supply at least this voltage under worst case current consumption assumed to be about 200miliampere.

Consider two joints of our leg, at both joints two DC motor are interfaced for movement in forward and reverse direction. To do the same, relay drives and relay circuit is used by which the phase sequence is maintained and movement of the motor in forward and reverse direction.

ULN2003 is used to drive the motor and called as relay driver circuit. To move motor in forward and reverse direction ULN2003 is used. 5V DC operated relay is used here based on the movement by pressing appropriate keys for the patient. Patient can get appropriate motion for setting down and standing up. By using auto mode, we can able to walk at standard walking.

5. SIMULATION

TABLE -1: OPERATING MECHANISM OF MOTORS

MOTION	MOTOR M1	MOTOR M2
Forward	Anticlockwise	Clockwise
Reverse	Clockwise	Anticlockwise
Automatic		
Forward	Anticlockwise	Clockwise
Delay	3 seconds	3 seconds
Reverse	Clockwise	Anticlockwise
Angle		
Forward	+25 degrees	-25 degrees
Reverse	-25 degrees	+25 degrees
Sitting position	0 degrees	90 degrees



Fig -4: Microcontroller Board

TABLE -2: CHARACTERISTICS OF MOTORS

Operating Voltage	5V
Operating Speed	30 rpm
Motor Type	DC Motor
Weight	7kg



Fig -5: Experimental Setup

6. RESULT



Fig -6: Forward Condition



Fig -7: Stop Condition



Fig -8: Reverse Condition

7. CONCLUSION

By using this robot supported leg the person can able to walk without any support. Also, we learn the design, fabrication & the analysis of robotic leg. The walking mechanism of robot is achieved by using keys & DC motors.

REFERENCES

- [1] M. Arbulu and C.Balaguer, "Human-Humanoid robot cooperation in collaborative transportation tasks", in Proc of Clawar 2008, Coimbra Portugal 2008
- [2] Lang Yuedong, "Design, stimulation and walking experiment for a Humanoid robot with Multiple Locomotion Modes".
- [3] S. Kajita, A. Kobayashi and T. Yamamura, "Dynamic walking control of robot along a potential energy conserving orbit".
- [4] Guan Y S, Yokoi K, Tanie K. Feasibility: Can humanoid robots overcome given obstacles? Proceedings of the IEEE International Conference on Robotics and Automation, Barcelona, Spain, 2005, 1054-1059.
- [5] Verrelst B, Stasse O, Yokoi K, Vanderborght B. Dynamically stepping over obstacles by the humanoid robot HRP-2. Proceedings of the 6th IEEE-RAS International Conference on Humanoid Robots, Genova, Italy, 2006, 117-123.