

GPS Based Soldier Tracking and Health Monitoring

Mr.Patil Akshay¹, Mr. Shelake Balaji², Mr. Pinjari Raju³, Ms.Mirajkar P.P.⁴

1Student, Department of Electronics and Telecommunication, Annasaheb Dange College of Engineering and Technology, Ashta, Maharashtra, India

2Student, Department of Electronics and Telecommunication, Annasaheb Dange College of Engineering and Technology, Ashta, Maharashtra, India

3Student, Department of Electronics and Telecommunication, Annasaheb Dange College of Engineering and Technology, Ashta, Maharashtra, India

4Assistant Professor, Department of Electronics and Telecommunication, Annasaheb Dange College of Engineering and Technology, Ashta, Maharashtra, India

Abstract - Army is one of the most important aspects of any country. It is our duty to equip soldier with better advanced technology. This paper helps to track the soldier at any given moment using GPS. In this paper, soldier's health parameters such as heart rate and body temperature are continuously measured and transmitted wirelessly to the control room using GSM. In case of death of the soldier, the processor detects the change in pulse rate and location of the dead soldier; tracked by the GPS module is then communicated to the military base station by the use of GSM. This information can be used to devise war strategies as to how many more soldiers (and where) should be deployed to replace the martyrs. It helps to minimize the time, search and rescue operation efforts of army control unit. This system enables to army base station to track the location and monitor health of soldiers using GPS module and wireless body area sensor networks, such as temperature sensor, heart beat sensor, etc.

Key Words: GSM, GPS, arduino Uno, tracking.

1. INTRODUCTION

Now-a-days Defense Services are rapidly growing towards new innovation with advance implementation.

Soldier's health is more important because they are the

defenders who protect our country. In today's world enemy warfare is a important factor in the nation's security. The national security mainly depends on army (ground), navy (sea), force (air). The important and vital role is played by the army soldiers. There are many concerns regarding the safety of these soldiers. As soon as any soldier enters the enemy lines it is very vital for the army base station to know the location as well as the health status of all its soldiers. In our project we have come up with an idea of tracking the soldier as well as to give the health status of the soldier during the war, which enables the army personnel to plan the war strategies. Also the soldier can ask for directions to the army base unit in case he feels that he is lost. By using the location sent by the GPS, the base station can guide the soldier to safe area. The system is composed of two parts, which are portable remote soldier unit and the monitoring centre. The portable remote soldier unit consists of Advanced RISC Machines (ARM) with the embedded operating system, GPS and a GSM, temperature sensor and heart beat sensor. To design a Soldier tracking system using GSM and GPS to provide wireless system for monitoring the parameters of soldier are as – Body temperature & Blood pressure. To find the health status of soldier biomedical sensors are

used, a body temp sensor to measure body temperature as well as pulse rate sensor to measure the blood pressure. These parameters are then signal conditioned and will be stored in the memory. One of the fundamental challenges in military operations lays in that the Soldier not able to communicate with control room administrator. In addition, each organization needs to enforce certain administrative and operational work when they interact over the network owned and operated by other organizations. Thus, without careful planning and coordination, one troop cannot communicate with the troops or leverage the communication infrastructure operated by the country troops in the same region.

2. PROBLEM SUMMARY

One of the fundamental challenges in military operations lays in that the Soldier not able to communicate with control room administrator. In addition, each organization needs to enforce certain administrative and operational work when they interact over the network owned and operated by other organizations. Thus, without careful planning and coordination, one group cannot communicate with the other groups. Current problem faced by the military are as follows:

1. Soldier wants to know about location. He can't do that.
2. They will not get help during panic situation.
3. Soldiers are not track able.

3. SYSTEM OVERVIEW

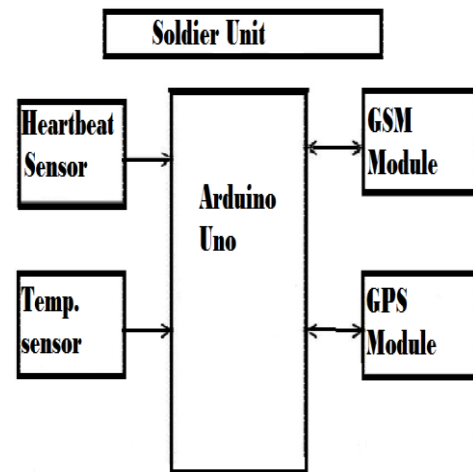

Fig1. Soldier unit

Fig.1 shows the block diagram of soldier unit which includes following blocks.

A. Heart beat sensor

- The Heart Beat sensor used for study the heart's function
- This sensor monitors the flow of blood through the finger
- As the heart forces blood through the blood vessels in the finger, the amount of blood in the finger changes with time
- The sensor shines a light lobe through the finger and measures the light transmitted to the LDR
- The signal obtained from the LDR is amplified by the amplifier and will be filtered

B. Temperature sensor

- The Temperature can be detected with the help of a temperature sensor LM35.
- The LM series are precision integrated circuit temperature sensors, whose output voltage is linearly proportional to the Celsius.

C. GSM Module

- The GSM Module is used to provide the information of the soldier like the heartbeat rate and the body temperature to a remote location
- It is similar to a mobile which requires a SIM card for its operation but the advantage of GSM module over mobile is that it has an serial connectivity that can be directly connected to the Micro controller for sending the AT(Attention) commands for sending SMS

D. GPS module

- The location of the soldier can be tracked with the help of a GPS Module
- The GPS module receives the signals from the satellite and calculates the Latitude and Longitude of the location of soldier and sends it to the controller.

E. Arduino Architecture

An Arduino is actually a microcontroller based kit. Arduino processor basically uses the Harvard architecture where the program code and program data have separate memory. It consists of two memories- Program memory and the data memory. The code is stored in the flash program memory, whereas the data is stored in the data memory. The Atmega328 has 32 KB of flash memory for storing code (of which 0.5 KB is used for the boot loader), 2 KB of SRAM and 1 KB of EEPROM and operates with a clock speed of 16MHz.

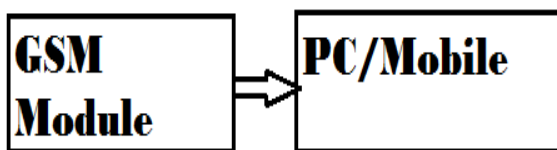

Fig2.Control Room's Unit

4. SOFTWARE IMPLEMENTATION

The most important advantage with Arduino is the programs can be directly loaded to the device without requiring any hardware programmer to burn the program. This is done because of the presence of the 0.5KB of Boot loader which allows the program to be burned into the circuit. All we have to do is to download the Arduino software and writing the code.

The Arduino tool window consists of the toolbar with the buttons like verify, upload, new, open, save, serial monitor. It also consists of a text editor to write the code, a message area which displays the feedback like showing the errors, the text console which displays the output and a series of menus like the File, Edit, Tools, and menu.

4.1 Steps to program an Arduino

Programs written in Arduino are known as sketches. A basic sketch consists of 3 parts

- Declaration of Variables
- Initialization: It is written in the setup () function.
- Control code: It is written in the loop () function.

The sketch is saved with .ino extension. Any operations like verifying, opening a sketch, saving a sketch can be done using the buttons on the toolbar or using the tool menu.

The sketch should be stored in the sketchbook directory.

Chose the proper board from the tools menu and the serial port numbers.

Click on the upload button or chose upload from the tools menu. Thus the code is uploaded by the boot loader onto the microcontroller.

5. CONCLUSIONS

We conclude that, This system helps to monitor health parameters of soldier using heart beat sensor to measure heart beats and temperature sensor to measure body temperature of soldier. This system helps the soldier to get help from army base station in panic situation. also this system provides the location information and health parameters of soldier to the army control room. Thus, this system provides security and safety to our soldiers.

REFERENCES

- [1] Hock Beng Lim-“A Soldier Health Monitoring System for Military Applications”-2010 International Conference on Body Sensor Networks (BSN).Page no(s) 246-249.
- [2] Shruti Nikam, Supriya Patil, Prajka Powar and V.S.Bendre-“ Gps-based soldier tracking and health indicationsystem”-International Journal of Advanced Research in Electrical, Electronics and Instrumentation Engineering.Vol. 2, Issue 3, March 2013. Page no(s) 1082-1088.
- [3] Mr. Rajdeep Limbu, Prof. V. V. Kale, “GPS Based Soldier Tracking and Health Monitoring System”, International Journal for Technological Research in Engineering, ISSN: 2347-4718, Volume 1, Issue 12, August 2014, pp: (1485-1488).
- [4] Rubina.A.Shaikh, “Real Time Health Monitoring System of Remote Patient Using Arm7”, International Journal of Instrumentation, Control and Automation, ISSN: 2231-1890, Volume 1, Issue 3-4, April 2012, pp: (102-105).
- [5] Ms. P. P. Mirajkar, Prof. S.D. Ruikar, “WAVELET BASED IMAGE FUSION TECHNIQUES” is published in CIIT International Journal of Digital Image Processing, Volume 4, No. 15, September 2012
- [6] Ekta Madhyan, Mahesh Kadam, “A Unique Health Care Monitoring System Using Sensors and ZigBee Technology”, International Journal of Advanced Research in Computer Science and Software Engineering, ISSN: 2277-128X, Volume 4, Issue 6, June 2014, pp: (501-509).

[7] Ms. P. P. Mirajkar, Ms. Kavathekar Jyoti, Ms. Madhuri Kamble, “AUTOMATIC POWER FACTOR RELAY USING PIC CONTROLLER” is published in IJARECE, ISSN 2278-909X, Volume 5, Issue 4, pp. 808-811 , April -2016

BIOGRAPHIES



1. Mr. Patil Akshay L. is Studying B.E in Electronic and Telecommunication Department of Annasaheb Dange College of Engineering and Technology, Ashta, Maharashtra, India.



2. Mr. Shelke Balaji D.: is Studying B.E in Electronic and Telecommunication Department of Annasaheb Dange College of Engineering and Technology ,Ashta, Maharashtra, India.



3. Mr. Pinjari Raju K.: is Studying B.E in Electronic and Telecommunication Department of Annasaheb Dange College of Engineering and Technology , Ashta, Maharashtra, India.



4. Ms. Mirajkar P.P. is working as Assistant Professor, in Electronic and Telecommunication Department of Annasaheb Dange College of Engineering and Technology, Ashta, Maharashtra, India. Her qualification is M.E.(VLSI & Embedded System)