

Business Intelligence (BI) Dashboard Utility

Ketan Joshi¹, Siddhesh Masurkar², Akhilesh Tawde³, Jyotsna Gharat⁴

¹²³Information Technology, Xavier Institute of Engineering, Maharashtra, India

⁴Professor, Xavier Institute of Engineering, Maharashtra, India

Abstract - To collect, review, or analyse large amounts of data is often overwhelming for any organization. Equally Mahaonline has massive amounts of knowledge hold on in their databases collected over numerous applications. We will be developing a dashboard for Maharecruitment which is an application under Mahaonline in G2C (Government to Customer) Domain. Government dashboards will allow managers to monitor and gauge exactly how well an application and its services are performing overall thus providing a snapshot of performance. The dashboard will also enable key insight into demographic profile of enrolled candidates and also into the process and performance of enrolment. Mahaonline officers can monitor all the information and obtain an oversight over the performance of their services. We propose a project on creating a Business Intelligence (BI) Utility, which is specifically sought to determine the optimal use of a business intelligence dashboard within the government organization.

Key Words: databases; Government dashboard; Business Intelligence; snapshot; demographic profile; enrolment

1. INTRODUCTION

Associations battle in gathering data, recovering information and making decisions in view of the separated information. A decision making strategy comprises of building judgments identifying with numerous speculations and assets upheld the quantitative and subjective data. Decisions in any association are made by people and not by frameworks and thus introduction of data assumes a noteworthy part inside the decision making process.

While using this application, department users and mahaonline users face difficulty analysing the candidate information and the recruitment process. Thus we are going to provide them with a Business Intelligence Dashboard Utility which is a tool to view and analyse data using dashboards.

Maharecruitment application mainly deals with candidate registration, profile creation, criteria verification, payment of fees and application for exams. Once the user criteria is verified and the payment is done the candidate is applicable for the exam. Mahaonline has such huge amounts of data stored in the government databases as well as the data collected through various applications. Collecting and analysing vast quantities of data has become a tedious

process. Thus the goal of our project is to provide mahaonline with a business intelligence tool which can be used over several applications to get an overview over the data collected and the processing of the application.

Our dashboard utility would provide some data visualization tools like pie charts, graphs, customization and drill-down. Our criteria of success would be determined by using this Business Intelligence dashboard utility to successfully implement and deploy a dashboard for the maharecruitment application.

2. PROPOSED SYSTEM

1.2. METHODOLOGY

Strategy is the precise, hypothetical examination of the routes connected to a field of study. It incorporates the hypothetical examination of the group of ways and standards identified with a branch of data. Ordinarily, it incorporates thoughts like worldview, hypothetical model, stages and quantitative or subjective methods and not by framework and thus introduction of data assumes a major part inside the choosing procedure.

1.2.2. SOFTWARE DEVELOPMENT LIFECYCLE MODEL

Developing a BI Dashboard Utility is a linear-sequential process thus waterfall model is the most suitable SDLC process model.

- **System Design:**

ASP.NET/MVC- Model View Controller [7] framework is used to design the dashboard utility. Model-view-controller (MVC) is a software architectural pattern for implementing user interfaces on computers. It divides a given software application into three interconnected parts, so as to separate internal representations of information from the ways that information is presented to the user.

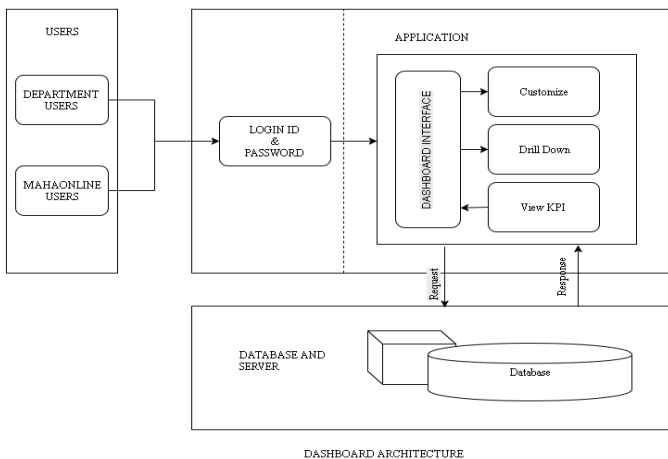

Fig -1: System Architecture

2.2 WORKING FLOW:

The working models the collaboration of objects supported by a time sequence for the job recruitment department website of govt. of Maharashtra. It shows how the objects interact with others in a specific situation where usage of services of the tool is carried out.

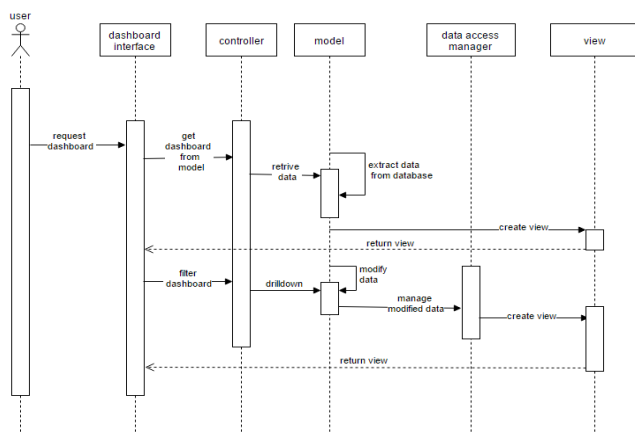

Fig -2: working flow diagram

3. DASHBOARDS OVER THE EXISTING SYSTEM

Business Intelligence Dashboard could be a screen that consolidates vital performance metrics all in one place, creating it simple for users to remain perpetually updated on the data most vital to their business.

In our system dashboard is designed for the job recruitment department of govt. of Maharashtra in which the database will consist of the user applications/form which will be filled by the applicants. This data will be then segregated and stored in the database. The dashboard will be consisting of different facts such as the no of applicants filled the form for the exam, district wise enrolment of applicants for particular exams, paid and unpaid applicants.

Dashboard which is created will allow the government officers to have a quick look for the applicants enrolled for a

particular exam and take proper decisions about the arrangement for the applicants, their payment process, district wise arrangements for their examination centres. Instead of going through each applicant and making a note of it manually a dashboard will give a quick look for what information is needed by the officer. This will save a lot of manual work as well as will save time and give the information quickly. This will help in making decision within no time avoiding the delay caused due to manual segregation of data.

4. CONCLUSIONS

Business Intelligence Dashboard Utility is a tool which is made for the job recruitment department of government of Maharashtra. This tool is created so that entire information of applicants can be collected and according to the information collected it can be displayed on the dashboard which will give the detail of all the applicants registered for the exams which are necessary of a particular exam. Dashboard of this tool will be showing the details of the applicants enrolled, district wise division of the applicants, paid and unpaid applicants for the exams which are necessary for particular job, online and offline payment made by applicants for that exams. Government Officers with the help of this data will be able to make proper arrangements for the applicants which are registering for particular exams. Government Officers will be having a quick look at the dashboard which will help them for taking proper decisions regarding the exams, their arrangements.

REFERENCES

- [1] Gerwald Tschinkel ; Cecilia Di Sciascio ; Belgin Mutlu ; Vedran Sabol, "The Recommendation Dashboard: A System to Visualize and Organise Recommendations" Information Visualisation , 2015 19th International Conference on 22-24 July 2015 ISSN: 1550-6037
- [2] ECKERSON, W.W. (2006) Performance Dashboards: Measuring, Monitoring and Managing Your Business, John Wiley & Sons, Inc.; Hoboken, New Jersey
- [3] SALLAM, R.L. (2011) "BI Platform Users Survey, 2011: Customers Rate their BI Platform Functionality", available at <http://bit.ly/GY3XgB>, (accessed 24 May 2011).
- [4] Judith Hurwitz, F. H. (2005). Dashboards — Enabling Insight and Action. Waltham Hurwitz & Associates.
- [5] Irny, S.I. and Rose, A.A. (2005) "Designing a Strategic Information Systems Planning Methodology for Malaysian Institutes of Higher Learning (isp- ipt), Issues in Information System, Volume VI, No. 1, 2005.