

DESIGN OF TESLA COIL

Rupesh Surwade¹, Hitesh Patil², Ashwini Parit³, Swarada Muley⁴

¹Student, Electrical Engg, Jspm's Bsiotr, Wagholi, Pune, Maharashtra, India.

²Student, Electrical Engg, Jspm's Bsiotr, Wagholi, Pune, Maharashtra, India.

³Student, Electrical Engg, Jspm's Bsiotr, Wagholi, Pune, Maharashtra, India.

⁴Assistant Professor, Electrical Engg, Jspm's Bsiotr, Wagholi, Pune, Maharashtra, India.

Abstract - The tesla coil is basically resonant transformer Which is used to produced potentials in the range of tens to hundreds, or even thousands of kilovolts. We explain the range of experiments design to investigate the tesla coil action, ending with design of upper toroid at the secondary side. This paper explain simple design of tesla coil where it is able to produce high voltage with high frequency current at secondary side. Tesla coil that has been in this report is recommended to be used for advanced studies particularly on wireless energy evolution.

Key Words: Alternating current (AC), Radio Frequency (RF).

1. INTRODUCTION

Nikola tesla(1856-1943) was one of the most great inventor in world history he invented the tesla coil, which is basically resonant air core transformer in 1891 he also did the work in the field of power and communication there invention have greatly changed the human life. The building of the tesla coil is also known as a coiling. Tesla coils or resonant transformer of high frequency and high potential have been used in many commercial application the tesla coil more than hundred years ago. Nikola tesla plans to transmit the electrical energy without wires. He thought that by building a big enough tesla coil, with enough high voltage, he could ionised the whole earth atmosphere, allowing it to conduct electricity.

1.1 Basics Of Tesla Coil

Tesla coil is a high frequency oscillator that drives in air core doubled tunned resonant transformer to produced high voltage at very low current for producing the oscillations we used the spark gap or we can also used the transistor in mini tesla coil. The tesla coil can produced the output voltage from 50kv to several million volts which is depend on secondary turns of the transformer the high voltage consists of rapid string of pulses radio frequency alternating current.

1.2 Components of Tesla Coil

The neon sign transformer converts the ac line voltage 230 volts into 5000 volts. This high voltage is used to charge

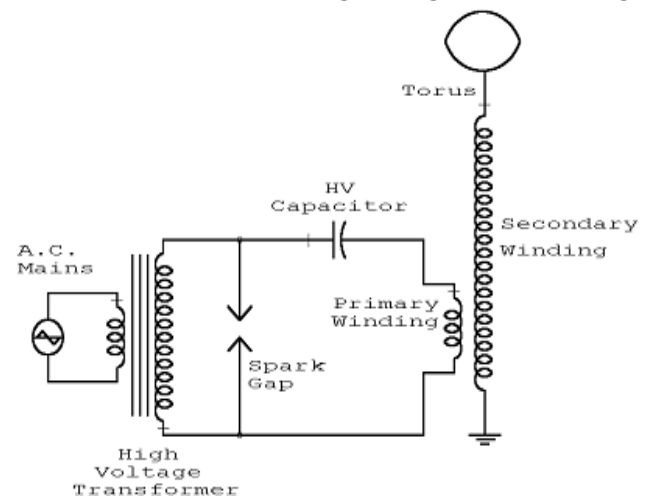

the capacitor. The capacitor is connect in series with the primary coil of output transformer. When the voltage value reaches to high enough to breakdown the spark gap, a spark will bridge the spark gap and complete the circuit between the capacitor and primary coil by shorting the transformer.

All the energy build up in the capacitor is forced through the primary coil. The process of charging the capacitor and firing of spark gap will occurs very rapidly. When the energy transfer to the primary coil, and electromagnetic field is created and surrounds the secondary coil. The secondary coil absorbs this energy and magnifies the voltage. Resulting in the high voltage.

Table -1: List of Components

Sr.no.	Component	Rating
1	Transformer	5kv,30mA
2	Capacitor	0.50µF,440vac
3	Sparkgap	-
4	Primary winding	No.of turns 10
5	Secondary winding	No. of turrns 950

2. Calculation

Vrms = 5000 volts

$$V_{\text{peak}} = \sqrt{2} * 5000$$

$$= 7071.06 \text{ volts}$$

$$C = \frac{1}{2\pi f \left(\frac{V}{I}\right)}$$

$$C = \frac{1}{2\pi * 50 * \left(\frac{5000}{0.03}\right)}$$

$$C = 1.90 * 10^{-8}$$

$$C = 0.019 \mu\text{f}$$

$$\text{Number of capacitor} = \frac{7071.06}{415}$$

$$\text{Number of capacitor} = 17.03 \text{ nus}$$

$$\text{Capacitance we get} = \frac{0.5}{17} \mu\text{f}$$

which is required = 0.029 μf .

3. Objective

- We always saw the electrical energy in different forms. i.e. light fan. Through the tesla coil we can see electricity visually.
- The tesla coil electricity can transmit without wires.

4. Advantages

- Charging is slow immediately after the spark gap fires.
- Provide excellent load sharing if 3 phase rectifier is use at high power.
- Allows power through put to be control by altering the rotary speed.

5. Applications

- Spark gap radio transmitters.
- Induction and dielectric heating (vacuum tube & Spark gap radio transmitters)
- Induction and dielectric heating (vacuum tube & spark gap types)
- Induction coils (differ only in the transformer core material being used).
- Medical X-ray devices (typically driven by an induction coil).
- Quack medical devices (violet-ray).
- Ozone generators.
- Particle accelerators.
- Electrical stage shows & entertainment.
- Generation of extremely high voltage with relatively high power levels

CONCLUSIONS

The goal of the this project was extend our knowledge of electrical electronics engineering and shed some light on the technical and artistic nature of Tesla coils, while attempting to create a unique and tesla coil. The coil that was created was capable of producing spark and spark was limited only by the lack of properly functioning of equipment. While there are a number of improvements that could be made the project served its initial purpose in creating a coil capable of acting as a power source and illuminating the finer points of creating such a coil. While designing the tesla coil we learned many things from our high voltage concepts and it also helpful in brush up of our knowledge in practical application. The main aim was to build and see the practical application of wireless electricity i.e. wireless transmission of electricity. Analyses of very simple improvementation geometries provide encouraging performance characteristics and further improvement is expected with serious design optimization. Thus the proposed mechanism is promising for many modern applications. We tried to design the unique tesla coil combining both electronics and electrical. By this project we minimized the distance between the electronics and electrical components as practical aspects.

REFERENCES

- [1] Thomas Cherian , "Audio Modulated Solid State Tesla Coil", *Transactions on engineering and science*, vol.2, Issue 5, page no. 65-68 5May 2014, ISSN:2347-1964 online 2347-1875.
- [2] M. B. Farriz, "A Simple Design of a Mini Tesla Coil with DC Voltage Input", *International Conference on Electrical and Control Engineering*, pp-4556-4559 978-0-7695-4031-3/10 \$26.00 © 2010 IEEE DOI 10.1109/iCECE.2010.1453.
- [3] Michal Krbal "Design And Construction Solution Of Laboratory Tesla Coil," *Department of Electrical Power Engineering*, Department of Power Electrical And Electronic



Engineering Brno University of Technology Brno", Czech
Republic978-1-4673-88-2/15/©2015 IE.