

Monitoring and Analysis of Aquatic Intake in Instructive Bodies

N Mohamed Athil¹, S Manikandan², J Babitha Thangamalar³, V.Soundaravalli⁴

¹Assistant Professor, Dept. of EIE, National Engineering College, Kovilpatti, TamilNadu

² Associate Professor, Dept. of EIE, National Engineering College, Kovilpatti, TamilNadu

³ Assistant Professor (SG), Dept. of EIE, National Engineering College, Kovilpatti, TamilNadu

⁴Assistant Professor, Dept. of EIE, National Engineering College, Kovilpatti, TamilNadu

Abstract - The outline of utmost organizations everywhere in the biosphere is aquatic intake. Aquatic intake is observed physically in instructive bodies and isolated segments. This needs a share of man power, plenty of period and leads to error. This paper recommended a system that contracts with wireless constant observing and study of aquatic intake rate. The stream of water in a pipe is measured by using turbine type Hall Effect instrument. The wireless communication is accomplished between fields and isolated observing division by means of RF module. Virtual Instrumentation shows a key role in real time study. Advance designs are made through LabVIEW software design.

Key Words: LabVIEW, DAQ, Real time analysis, RF module.

1.INTRODUCTION

Effective aquatic managing method consist of providing water rendering to the physical necessity and thus computing water is vital phase in aquatic managing method. There are many water stream procedures as well as dissimilar types of water flow patterns are used to measure the capacity of water stream in pipes. Precise stream measurement is a necessary phase in cooperation with qualitative and commercial point of view. Flow meters are the precise procedures for computing water stream and also cool to construct a truncated - price water managing method. The sensor is fitted in the pipeline where water intake observing is needed. The sensor's output is then transmitted to isolated monitoring section using RF transmission. In monitoring section, the received signal is acquired by the LabVIEW through DAQ. The operations are accomplished in LabVIEW to display the water intake level. Advance Analysis can be made through the stored data in MS Excel.

2. HARDWARE DESCRIPTION

2.1 Sensor

Water Flow Sensor YF-S201 which is shown in Fig. 1, can be used to measure the flow of liquids in both industrial and domestic applications. This sensor basically consists of a plastic valve body, a rotor and a Hall Effect sensor. The sensor sits in line with the water line and contains a pinwheel sensor to measure how much liquid has moved through it. The pinwheel rotor revolves when water flows through the valve and its speed will be directly comparative to the flow rate. There is an integrated magnetic Hall Effect sensor that output an electrical pulse with every revolution of the pinwheel rotor. The Hall Effect sensor is sealed from the water pipe and allows the sensor to stay safe and dry. This water flow sensor module can be easily interfaced with Microcontrollers, Arduino Boards and Raspberry - Pi.



Fig. 1. Water Flow Sensor (YF-S201)

The relationship between the water flow and the pulse is determined through multipoint calibration. These parameters are noted for different flowrate within the sensor's working flowrate (1-30l/min). Calibration factor i.e. water flow for a single pulse is obtained from the observed readings.

2.2 RF Module

Pulses from sensor is sent through RF module to the Remote monitoring section. By interfacing RF transmitter (WS-TX-01) with encoder (HT12E), it is possible to transmit the digital pulses as RF signal. Decoder (HT12D) is interfaced with RF receiver (WX-RX-02) to get the transmitted digital pulse. The frequency of the pulse from sensor is too high compared with the RF module frequency so that the frequency of pulse is decreased by 15 through Arduino programming before the transmission of it. The transmission range of RF module is 100m.

2.3 Data Acquisition (DAQ)

LabVIEW systems provide us with PC – based data acquisition. When data is collected from an instrument it passes through three areas of interest. At the lowest level, a sensor detects a physical occurrence and sends it back via a signal to the PC. There, a device known as a Data Acquisition (DAQ) card takes the signal and converts it into digital data that can be processed by the computer. Data acquisition is done by digital DAQ card (NI 9401). After the transmission, the data at the receiver end is acquired by the LabVIEW software through DAQ (Data Acquisition) card.

2.4 LabVIEW Environment

LabVIEW (Laboratory Virtual Instrument Engineering Workbench) is a graphical software design language that uses icons, instead of lines of text to create applications. It consists of three main components called Front panel, Block diagram and Connector pane. LabVIEW uses data flow programming, where the flow of data through the nodes on the block diagram determines the execution

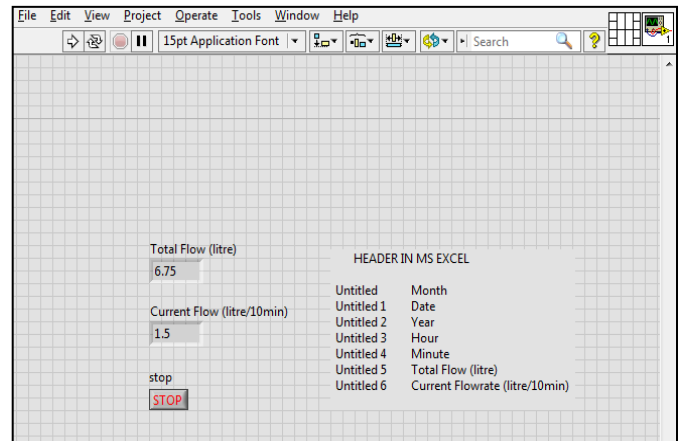

Fig. 2. Front Panel window in LabVIEW

order of the VIs and functions. VIs, or Virtual Instruments, are LabVIEW programs that imitate physical instruments such as oscilloscopes and multimeters. Front Panel window acts as a display section or monitoring section is illustrated in Fig. 2. The water consumption at particular interval is indicated as Current Flowrate (litre/10min) on the front panel. In this case the interval is 10 minutes. So, for every 10 minutes the amount of water consumed is displayed continuously. The continuous monitoring of utilizing water is displayed on the front panel by means of numeric indicator as Total Flow (litre) until Stop button is pressed. The whole program is terminated by pressing the Stop button.

VI program is developed in the block diagram window where the digital data acquired from DAQ is converted into user readable format. The block diagram of VI is shown in Fig. 3. DAQ assistant icon is used to configure the DAQ with LabVIEW and Write to Measurement file icon is used to store the water consumption rate in MS Excel.

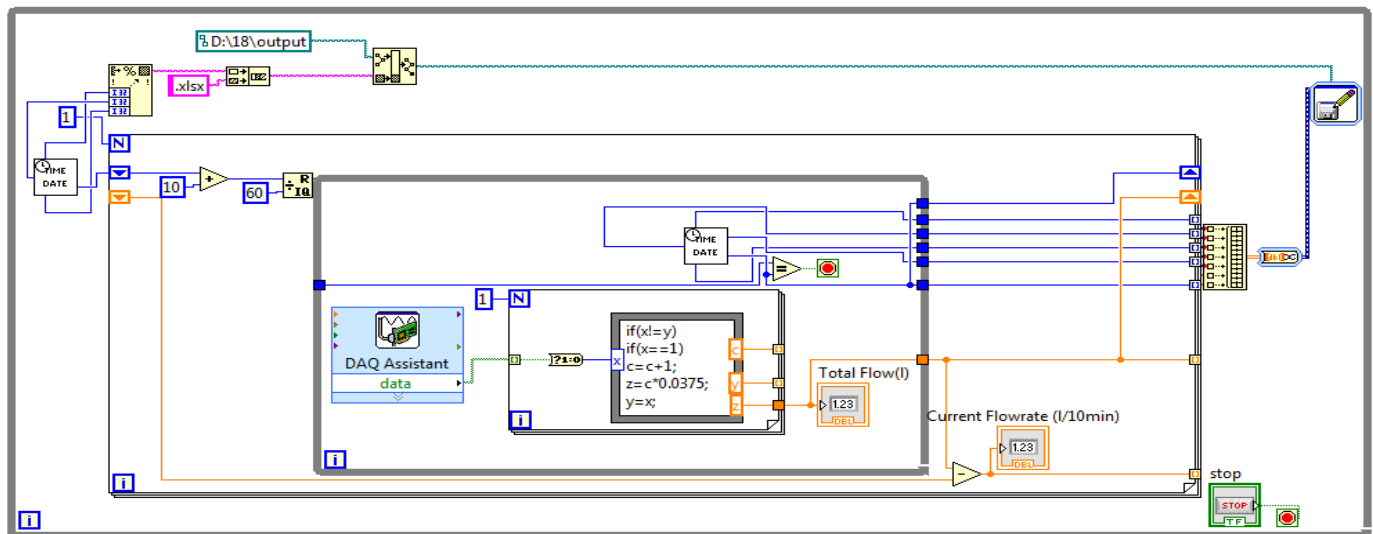

Fig. 3. Block Diagram window in LabVIEW

This system is implemented in a pipeline, mounted between source tank and user node. From this arrangement, the water consumption is monitored through the pipeline for few days. The monitored data are recorded automatically in MS Excel for every 10 min interval and the file is saved as MM DD YYYY. The saved data and its graphical representation are shown in Fig. 4.

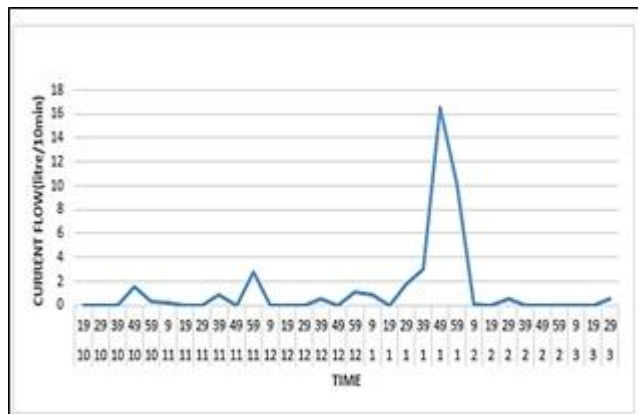

Fig.4.Analysed data as on 02/24/2017

3. CONCLUSIONS

The technologically advanced system offers the user with the real time monitoring system, which can help the users change their water usage and reduce water consumption as well as to identify and fix abnormal consumption. Also the end-user is provided with instant water usages and hence it makes awareness about the consumption. The whole system was tested for real time measurements. The data is continuously displayed and recorded by a file per day. Calibration of the sensor is the main challenge that is to be overcome while implementing this system. The system is designed and implemented successfully.

4. FUTURE SCOPE

This work deals with continuous monitoring and analysis, it can be extended with control action. On the implementation of this system, by knowing the water consumption rate, flow rate can be controlled by making control valve arrangement. Leakage problem can be detected on fixing extra nodes at the source tank and at every user end

ACKNOWLEDGEMENT

The authors would like to thank Ms.Soundravalli, Ms.Porselvi, Ms.Thebaral UG Students of Electronics and Instrumentation department, National Engineering College, Kovilpatti and we extended our thanks to teaching staffs, non-teaching staffs and management for their help and

suggestions which is more helpful for us and also we thank them for the facilities extended to us for completing the task.

REFERENCES

- [1] Bala Murugan, H. Siva Nagaraju, S.V. Sathish Kumar, K. Ramakrishnan, K.C. Sowjanya V.E. (2013) 'PV Solar cell Real time data Monitoring using Lab VIEW and DAQ', IJAREEIE, Vol 3, Issue 8, August 2013, p. 4093-4098,4100.
- [2] Mduduzi John, Mudumbe and Adnan M. Abu-Mahfouz (2015) 'Smart Water Meter System for User-Centric Consumption Measurement', an IEEE paper.
- [3] Popa, M. Ciocarlie, H. Popa A.S. and Racz, M.B. (2010) 'Smart Metering for Monitoring Domestic Utilities', 14th International Conference on Intelligent Engineering Systems (INES).
- [4] Ian Abbott Donnelly, Ed., 'Water consumption Monitor' US patent US20120022803 A1, Jan 26, 2012.
- [5] LabVIEW Getting Started with LabVIEW, National Instruments.
- [6] LabVIEW Data Acquisition VI Reference Manual, National Instruments.
- [7] LabVIEW NI 9401 operating instructions and specifications, National Instruments.
- [8] www.ni.com/labview
- [9] www.arduino.cc.