

MONITORING OF DISTRIBUTION TRANSFORMER PARAMETERS USING PLC

Shubhangi Landge¹, Snehal Waydande², Sanjay Sangale³, Somesh Gaikwad⁴

¹Assistant Professor, Dept. Of Electrical Engineering, AISSMS IOIT College, Maharashtra, India

^{2,3,4}Pune University, AISSMS IOIT College, Maharashtra, India

Abstract : Main aim of studying this paper is to design and implementation of PLC (programmable logic controllers) automation to monitor as well as to diagnose condition such as load, currents, transformer temperatures and voltages of the Distribution transformers of substation which is one of the most important equipment in the power system network. The Data acquisition, condition monitoring, automatic controlling are important issues as there are large no of transformers and various components over a wide area in power system.

In proposed system with PLC, relays and sensors are used to detect the faults of transformer such as overloading, overvoltage, under-voltage, phase to phase fault and over temperature faults. Probability of faults on distribution transformers is undoubtedly more and hence protection of transformer is highly essential.

Automation control is used for various systems for operation of equipments. Some processes are completely automated. Benefit of automation is it saves labor and saves energy and material; improve quality, accuracy and precision. Reduces dependency on human presence and decision making for any process

Keywords-PLC automation, Distribution transformer, Relays, sensors, Monitoring.

1. INTRODUCTION

A distribution transformer is a transformer that provides the final voltage transformation in the electrical power distribution system stepping down the voltage used in the distribution lines to the level used by the customer. Distribution transformers normally have ratings less than 200 KVA although some national standards can allow for unit up to 5000 KVA to be described as distribution transformer. Since these transformers are energized for 24 hours a day, its proper working is very important and so a strong protection is required.

The main concern of this paper is to rescue the distribution transformer in power system network against the internal and external faults. Overloading of transformer beyond the rating can cause a rise in temperature of both transformer oil and winding, overloading is nothing but it is an over current fault occurring on secondary side of distribution transformer or rise in the load. Increase in the winding temperature will increase the stress on the insulation, and then insulation deteriorates and may fail. Power system faults external to transformer can increase or decrease the voltage of the transformer, which leads to overvoltage or under-voltage fault. When fault occurs current increases, and hence a comprehensive transformer protection scheme needs to include protection against overvoltage, under-voltage, overload, phase to phase fault and over temperature. Following system is a proposed system which consist all this protections.

2. LITERATURE SURVEY

For this we have referred 1) Monitoring and Controlling of Distribution transformer using PLC, International Journal of Emerging Research in management and technology IJERMT paper (volume-5, Issue-5)

2) A review of Transformer Protection by using PLC system, International Journal of Digital Application and Contemporary research paper (Volume-3, Issue-2, September 2014)

3. FAULTS TO BE DETECTED

Under Voltage Fault

When the operating voltage decreases to lower limit of voltage rating, the under voltage fault will occur. This fault can be detected by voltage sensor. .

Over Voltage Fault

There may be always a chance of system over voltage due to sudden disconnection of large load. The magnitude of this voltage is higher than its normal level but frequency is same as it was in normal operating condition. Over voltage in the power system causes an increase in stress on the insulation of transformer. When the operating voltage increases to upper limit of voltage rating, the over voltage fault will occur. This fault can also detect by voltage sensor.

Over current fault (Overload)

Over current fault is mainly due to overload in secondary side of distribution transformer. Over current conditions are typically very short in duration (less than two seconds) because protection relays usually operate to isolate the faults from the power system line. Overload is current drawn by load, a load current in excess of the transformer name-plate rating at secondary side. Current increases the hottest-spot temperature (and the oil temperature), and thereby decreases the insulation life span. When the operating current increases to upper limit of current rating, the over current fault will occur. This fault can be detected by current sensor.

Over Temperature Fault

Not only over load current may not result in damage to the transformer but also the absolute temperature of the windings and transformer oil remains within specified limits. The ratings of transformer are based on a 24-hour average ambient temperature of 30°C (86°F). Due to over voltage and over current, temperature of oil increases which causes failure of insulation of transformer winding. When the temperature of transformer increases to upper limit of temperature rating, the over temperature fault will occur. This fault can be detected by temperature sensor like thermistor.

Phase to Phase Fault

Phase to phase fault (L-L fault) in the transformer are very rare. When this type of fault occurs, it results in rise of current to operate the instantaneous over current relay on the primary side as well as the differential relay. Three relays are placed on each three phases of input lines. This relays are used in two ways. First way is that it will trip the main circuit when any fault occurs. And second way is that PLC will check continuously to main current. If phase to phase fault will occur then relay trips the circuit.

4. BLOCK DIAGRAM OF PROPOSED SYSTEM

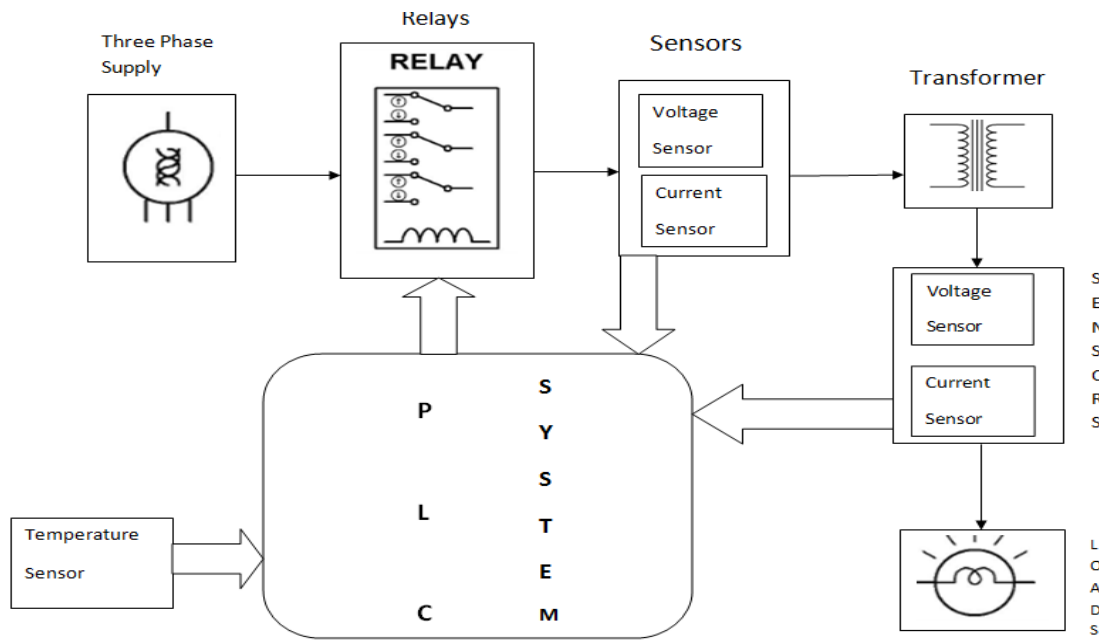

Figure 1. Transformer fault detection diagram

5. EQUIPMENT USED

A. Three Phase Transformer (440V/230V)

Used to step down 440 Volts to 230 Volts.

B. Relays

Three simple electromechanical relays are used and are connected in three phase connection of primary winding of transformer. Each relay is placed on each phase of transformer for detection and tripping purpose.

C. Current Transformers, Potential Transformers and Temperature Detector

Two measuring and protection equipments like current transformer and potential transformer are used. Temperature detector used is Thermistor.

D. Rectifier Circuit

This circuit is used to provide supply to sensors. This circuit is converted from 12V AC to 12V DC.

E. PLC System

In this project, PLC used is Micro-logix 1400 B series, Programmable Logic Controller used is of Schneider Company.

F. Power supply

A 415V three phase power supply is required to supply the three phase transformer and separate power supply is needed for PLC.

G. Load

For convenient and reliable operation of this project, 10 LED lights are used which are connected to rectifier output (12V DC) for indication of fault and resistive bank of 415 V 15 Amp is used at the secondary side of the transformer.

6. NEED FOR PLC

In this system PLC plays a very vital role as it is used for protection purpose. A Programmable logic controller is an industrial automation or computer control system that continuously monitor the state of input device and makes decisions upon a custom program to control the state of output devices. Automated system can be a machine or a process and can also be called a process control system. Function of process control system is constantly watched by input devices (sensors) that gives signals to a PLC controller. Also wiring and debugging of hardware panels is very time consuming. When hardware panels are replaced by computer controller following requirements are needed.

- 1)Solid state system
 - 2) Easy to modify I/O devices
 - 3)Be able to function in an Industrial environment.
- PLC logic used can be any such as Graphical logic, Ladder logic or Functional Block diagram out of which Ladder logic is used in the paper.

7. LADDER LOGIC USED IN PROPOSED SYSTEM

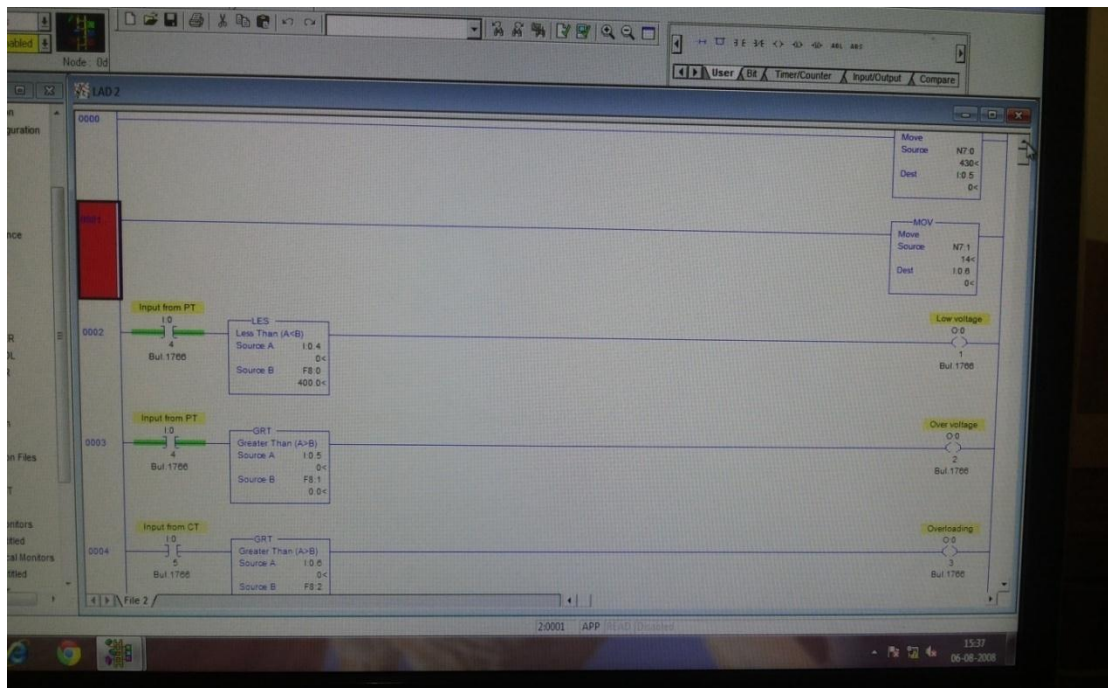
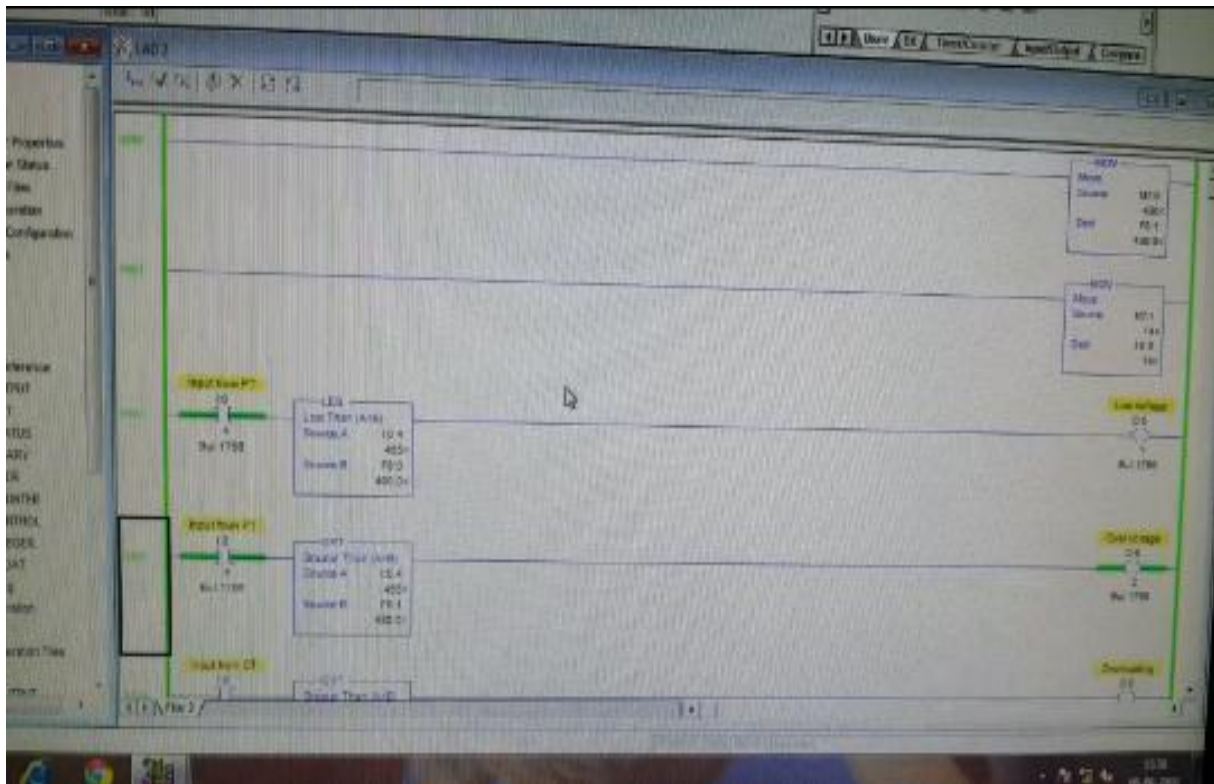

Figure 2. Ladder logic of PLC

8. ALGORITHM

- Less than and greater than instructions are used for over voltage and under voltage and greater than and equal to used for overloading.
- Create ladder diagram
- Set the parameters
- Download the program
- Go online
- When Output of PT less than set value it indicates under voltage
- When Output from PT greater than set value it indicates over voltage
- When Output from CT greater than set value it indicates Overloading
- Relay trips and Buzzer on

9. RESULTS FROM TESTING



1. When overvoltage LED assigned to this fault glows.

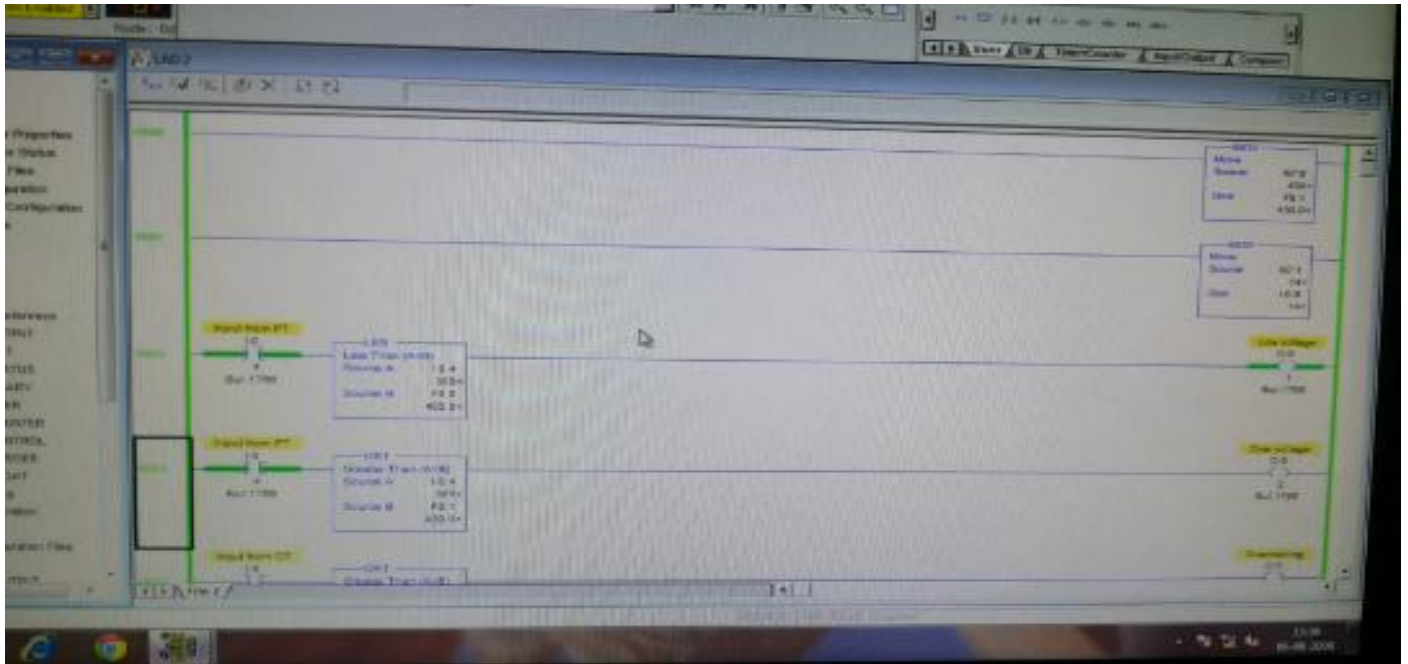

2. When low voltage LED assigned to this fault glows.

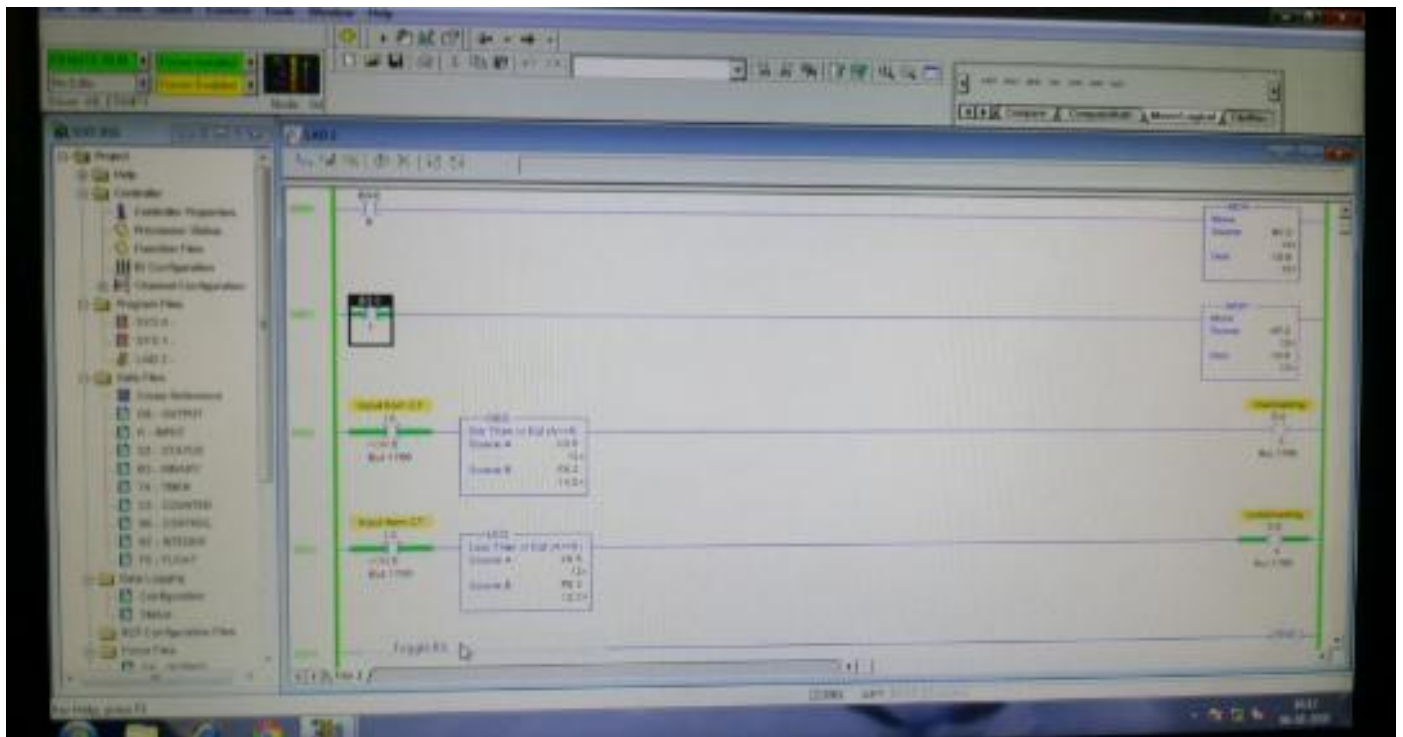

3. When over current LED assigned to this fault glows.

10. CONCLUSION

This paper presents a design of a system based on PLC that is used to monitor and control the voltage, current and temperature of a distribution transformer in both sides. The proposed PLC system which has been designed to monitor the transformer's essential parameters, it continuously monitors the parameters throughout its operation. When the PLC recognizes any increase or decrease in the level of voltage, current or temperature values the unit has been made shutdown in order to prevent it from further damages with the help of relays in three phase system. The system not only controls the distribution transformer in the substation by shutting it down, but also displays the values throughout the process for user's reference in SCADA system. This claims that the proposed design of the PLC system makes the distribution transformer more robust against some key power quality issues which make the voltage, current or temperature to peak. Hence the distribution is made more secure, reliable and highly efficient by means of the proposed system.

11. REFERENCE

1. A Review of Transformer Protection by Using PLC System -Dr. S. P. Shukla Professor, (Electrical Engineering),Bhilai Institute of, Technology, Durg, India.
2. Sumaryadil,B.Cahyonol,"ThermalMonitoringonPower Transformer", IEEE 978-1-4244-1622-6/08
3. Multidisciplinary journal of research in Engineering and technology.
4. Rohan Perera & Bogdan Kasztenny, "Application Considerations When Protecting Lines With Tapped and In-Line Transformers", previously presented at 2014 Texas A&M Conference for Protective Relay Engineers, © 2014 IEEE – All rights reserved. 20140210, TP6575-01.
5. T. S. Madhavrao, "Power System Protection n- Static Relays", TMH Publication
6. Monitoring and Controlling of Distribution transformer using PLC, International Journal of Emerging Research in management and technology IJERMT paper (volume-5, Issue-5)
7. A review of Transformer Protection by using PLC system, International Journal of Digital Application and Contemporary research paper (Volume-3, Issue-2, September 2014)