

TRANSFORMER MONITORING AND CONTROLLING WITH GSM BASED SYSTEM

Ms. V. A. PATIL¹, Ms. NAMRATA S. KUMBHAR², Ms. SHITAL S. PATIL³

¹Assistant Professor, Department of Electronics and Telecommunication, ADCET, Ashta, Maharashtra, INDIA

²Student, Department of Electronics and Telecommunication, ADCET, Ashta, Maharashtra, INDIA

³Student, Department of Electronics and Telecommunication, ADCET, Ashta, Maharashtra, INDIA

Abstract –

Transformers are a vital part of the transmission and distribution system. Monitoring transformers for problems before they occur can pre-vent faults that are costly to repair and result in a loss of service. An innovative design to develop a system for monitoring the voltage, current and temperature, oil level, theft of a distribution transformer in a substation and to protect the system from the mentioned parameters based on GSM that is used in this paper. Providing the protection to the distribution transformer can be accomplished by shutting down the entire unit with the aid of the Radio frequency Communication. This mobile system will help the transformers to operate smoothly and identify problems before any catastrophic failure. Moreover the system displays the same on a PC at the main station which is at a remote place. The proposed design is developed for the user to easily recognize the distribution transformer that is suffered by any problems.

Key Words: Distribution Transformer, Arduino controller, GSM.

1. INTRODUCTION

A monitoring system can only monitor the operation state or guard against steal the power, and is not able to monitor all useful data of distribution transformers to reduce costs. Temperature and over voltage. If the increase in temperature rises higher than the desirable temperature, the monitoring system will protect the distribution transformer by problems. According to the above requirements, we need a distribution transformer real-time monitoring system to

detect all operating parameters operation, and send to the monitoring centre in time. It leads to online monitoring of key operational parameters of distribution transformers which can provide useful information about the health of transformers which will help the utilities to optimally use their transformers and keep the asset in operation for a longer period. This will help to identify problems before any serious failure which leads to a significant cost savings and greater reliability.

2. Methodology

1. Studying literature on different transformer monitoring.
2. Studying the existing method transformer monitoring.
3. Analyze and design for the proposed system.
4. Implement the proposed design of transformer monitoring and controlling with GSM based system.
5. Carrying out experiment and evaluate the system.

3) Brief introduction of project

3.1) Related work:

1. An analysis of these problems and various suggestions about the development of the present research work on the transformer monitoring has been presented by Alessandro Ferrero. Monitoring and controlling of substations is an important task for supplying healthy power to the consumers in this automated era. But due to the aging infrastructure of the distribution grids (substations) and lack of automation systems that monitors the critical conditions at the substations, the risk of blackouts, brownouts and fire are rapidly increasing. Substations consist of different

electronic components like transformers, circuit breakers, relays etc. The transformer fluid leaks or internal insulation breakdown cause overheating that leads to failures. The traditional method includes periodic manual checking of the system which is time consuming and with very low accuracy. Also the substations in the rural areas are even more difficult to monitor manually and hence requires more time to take respective actions.

2. Distribution transformers have a long service life if they are operated under good and crated conditions. However, their life is significantly reduced if they are overloaded, resulting in unexpected failures and loss of supply to a large number of customers thus effecting system reliability. Overloading and ineffective cooling of transformers are the major causes of failure in distribution transformers. Most power companies use Supervisory Control and Data Acquisition (SCADA) system for online monitoring of power transformers but extending the SCADA system for online monitoring of distribution transformers is an expensive proposition. Distribution transformers are currently monitored manually where a person periodically visits a transformer site for maintenance and records parameter of importance. This type of monitoring cannot provide information about occasional overloads and overheating of transformer oil and windings. All these factors can significantly reduce transformer life.

3.2Proposed System:

Distributed transformers are prone to damages due to the raise in oil temperature when there is an overload or huge current flows through the internal winding of the transformer. When the oil temperature rises, it increases the probability of getting damages in the transformers. The transformers are to be monitored very cautiously during these situations. The proposed system consists of a monitoring unit that is connected with the distribution transformer for the purpose of monitoring the same.

The controller consists of a sensing unit which collects the essential parameters such as current, voltage and the oil temperature within the distribution transformer. The digital display connected to the processing unit displays corresponding parameter values at the substation for any technical operations. The controller also senses the overload and high current flow conditions in the internal windings that may lead to breakdown of the corresponding unit. The Arduino controller is programmed in such a manner so as to continuously scan the transformer and update the parameters at a particular time interval. The parameter values sensed by the Arduino-controller are transmitted through the ADC transmitter connected to the Arduino controller unit.

4)Block diagram:

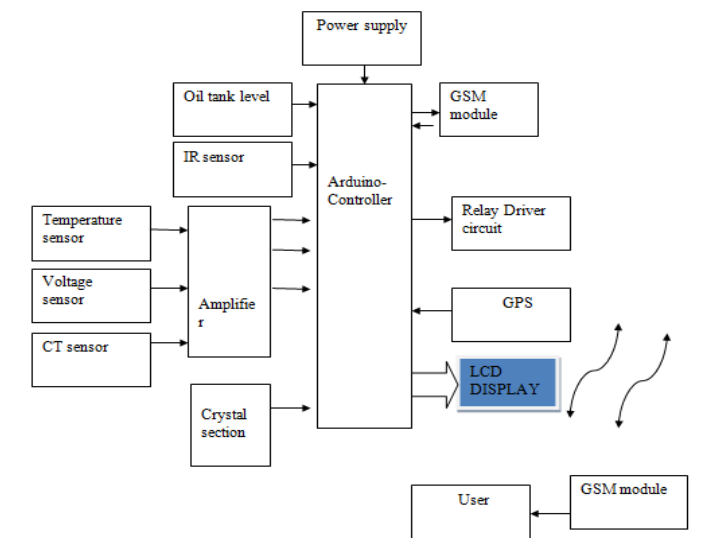

5. DESIGN OF SYSTEM:

5.1) Hardware Implementation

In this system, power supply is used to provide the power to the whole sensors, Arduino, GSM, GPS are the main components used for designing the system. When power supply is given system worked. Arduino is automatically interfaced and the output is displayed on the LCD display.GSM through message send to user understand mentioned parameter and location of transformer by GPS.

5.2) Software Implementation:

For Software Implementation we have used the software “c”. In Software Implementation, The main part is programming of Arduino and Interfacing of each device like sensors. Once the power supply is given hardware circuit is get initialized. The Arduino interfacing with LCD display. Which display parameters info like voltage, current, temperature and tank level. When any problem occurs in transformer it will display on LCD. After display data on LCD it sends to user through GSM modem. Then suddenly data message send to user mobile so user understand which transformers problem occur.

5.3) Flow Chart:

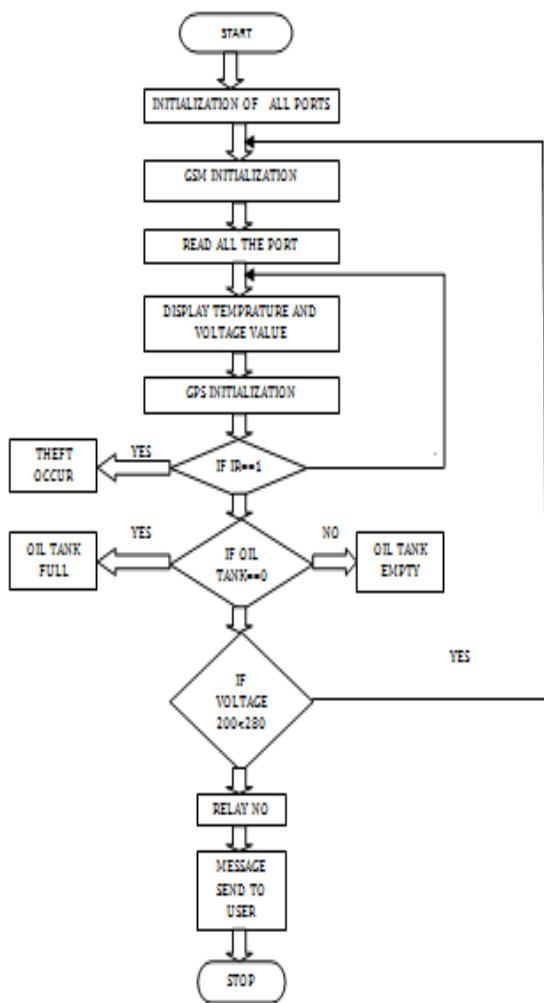

5.4 Components of Hardware in System:

1. SENSORS:

Sensors are installed on transformer site which reads and measures the physical quantity from the distribution transformer and then it converts it into the analog to digital. Sensor are used for sensing load current, voltage, temperature, oil level and any obstacles. A sensor is a device which receives and responds to a signal when touched or condition occurs in given parameters sensor. A multitude of different measurable variables can be collected for on-line monitoring. However, it is very rarely useful to use the entire spectrum. Therefore, sensor technology must be adjusted to the specific requirements of a particular transformer depending on their age and condition. These sensors as follows

1. These sensors have a permanent magnet in the float. It helps to sense the level of oil present in the overhead tank or sump.
2. RTD PT 100 for temperature of transformer.
3. For current and voltage used model cs-sc-200..
4. LM358 IC 2 for IR transmitter and receiver pair.

2. Arduino controller:

The Arduino Uno has a number of facilities for communicating with a computer, another Arduino, or other microcontrollers. The ATmega328 provides UART TTL (5V) serial communication, which is available on digital pins 0 (RX) and 1 (TX). The Arduino software includes a serial monitor which allows simple textual data to be sent to and from the Arduino boards. Interfacing between parameters and GSM Model system.

3. GSM:

GSM was intended to be a secure wireless system. However, GSM is vulnerable to different types of attack, each of them aimed at a different part of the network. The development of UMTS introduces an optional USIM, that uses a longer authentication key to give greater security, as well as mutually authenticating the network and the user, whereas GSM only authenticates the user to the network (and not vice versa). The security model therefore offers confidentiality and authentication, but limited authorization capabilities, and no non repudiation. In the system any problem of given parameters then suddenly message will be send to the user. To solve problem of transformer it's important to send message.

4. GPS:

The Global Positioning System (GPS) is a space-based navigation system that provides location and time information in all weather conditions, anywhere on or near the Earth where there is an unobstructed line of sight to four or more GPS satellites. It provides to system location of transformers. so user understand which transformer faulty or any problem occur in distribution transformer. It reduces time to reach transformer location giving location info.

5. Power supply

The Arduino need +5V DC, These specifications dictate the use of a low-cost, ubiquitous linear regulator National Semiconductor LM7805. The LM7805 requires an input voltage of at least 7.5V in order to guarantee regulation, so the unregulated power supply should supply at least this voltage under worst-case current consumption, assumed to be about 200mA

6 CONCLUSIONS:

Transformers are among the most generic and expensive piece of equipment of the transmission and distribution system. Regular monitoring health condition of transformer not only is economical also adds to increased reliability. The GSM based monitoring of distribution transformer is useful as compared to manual monitoring and also it is reliable as it is not possible to monitor always the oil level, temperature rise, load current, voltage, theft occur manually. Transformer is undergoing fault from the message sent to mobile. We can recover the system in less time.

REFERENCES:-

- [1]. Jyotishman Pathak, Yuan Li, Vasant Honavar and James D. McCalley, "A Service-Oriented Architecture for Electric Power Transmission System Asset Management", In ICSOC Workshops, pp: 26-37, 2006.
- [2]. B. A. Carreras, V. E. Lynch, D. E. Newman and I. Dobson, "Blackout Mitigation Assessment in Power Transmission Systems", Hawaii International Conference on System Science, January 2003.
- [3]. Xiaomeng Li and Ganesh K. Venayagamoorthy, "A Neural Network Based Wide Area Monitor for a Power System", *IEEE Power Engineering Society General Meeting*, Vol. 2, pp: 1455-1460, 2005.
- [4]. Argonne National Laboratory, "Assessment of the Potential Costs and Energy Impacts of Spill Prevention, Control, and Countermeasure requirements for Electric Utility Substations", Draft Energy Impact Issue Paper, 2006.
- [5]. R.R. Negenborn, A.G. Beccuti, T. Demiray, S. Leirens, G. Damm, B. De Schutter and M. Morari, "Supervisory hybrid model predictive control for voltage stability of power networks", *Proceedings of the 2007 American Control Conference*, New York, New York, pp: 5444-5449, July 2007.
- [6]. Daponte, M. Di Penta and G. Mercurio, "TRANSIENTMETER: A Distributed Measurement System for

Power Quality Monitoring", *IEEE Transactions on Power Delivery*, Vol. 19, Issue. 2, pp: 456-463, 2004.

BIOGRAPHIES



Ms. Viddulata A. Patil is working as a assistant professor in ADCET, Ashta. She has completed ME electronics from Shivaji University. She has 11 Years of teaching experience. Her area of Interest is analog electronics and Image Processing



NAMRATA S.KUMBHAR pursuing the BE in Electronics & Telecommunication in Annasaheb Dange Collage of Engineering &Technology, Ashta.



SHITAL S. PATIL pursuing the BE in Electronics & Telecommunication in Annasaheb Dange Collage of Engineering &Technology, Ashta.