

# Floating TEG Integrated Solar Panel Hybrid Energy Harvesting System

Parth Kuchroo<sup>1</sup>, Hemant Bhatia<sup>2</sup>, Ekambir Sidhu<sup>3</sup>

<sup>1</sup>Department of Mechanical Engineering, Punjabi University, Patiala, India

<sup>2</sup> Department of Mechanical Engineering, Punjabi University, Patiala, India

<sup>3</sup>Assistant Professor, Department of Electronics and Communication Engineering, Punjabi University, Patiala, India

\*\*\*

**Abstract** - This paper presents an energy harvesting system employing Thermoelectric Generators (TEG) integrated with Solar panel. The proposed system has been so designed that it is able to harvest both solar energy as well as thermal energy simultaneously, resulting it to be termed as hybrid EH system. In the proposed research work, the solar radiations are made to fall on the solar panel, which is efficient enough to harvest the light radiations falling on it. But these radiations result in the heating up of the solar panel, leading to the reduction in its efficiency. The thermoelectric generators are employed at the back side of the solar panel which absorb this heat and generate an electrical output if suitable temperature gradient is maintained across its both the surfaces. The suitable heat sink employed for the TEG's is the continuous water flow from the waterfalls which helps in sustaining the appropriate temperature difference across its faces. The solar panel installed is able to generate voltage between +9 Volt to +12 Volt while the thermoelectric generators placed at the rear side are able to generate an average voltage between +3 Volt to +6Volt. When the two pairs of six TEG's (in series) are connected in parallel, the average output power obtained is 898.54 milli-Watts while the two pairs of six TEG's (in parallel) are connected in series, the average output power obtained is 230.57 milli-Watts. The former arrangement of array of thermoelectric generators is found to be 49.7 percent more efficient compared to later one in still water conditions. The harvested energy by solar panel and TEG's is proficient enough to charge a +12 Volt rechargeable battery.

**Key Words:** battery, floating thermoelectric generator, hybrid EH system, polyurethane foam, running water

## 1. INTRODUCTION

With the advent of new technology, the demands of energy have also arisen leading to increment in the exploitation of the natural resources. But with these sources being limited, we have to search for other alternatives. There are several potential environmental energy sources available from "natural" environment such as sun light, wind or geothermal energy [1]. The harvesting of the sun's light and heat

energy, which is one of the available abundant energy resources is the most efficient way of generation of electrical energy. Solar energy has been considered as a cost effective source of renewable energy available in abundance in ambient surroundings [2]. The solar harvesting system employing solar panels are used in conversion of light energy into electrical energy by the process of photovoltaic energy generation [3]. The efficiency of the solar devices depend on the radiant intensity of the sun rays and the area of the device being exposed to incident light rays. The Earth receives sun rays at a rate of 1300 Watts power per hour per meter every day [4], although of which 30 percent is reflected back, still it produces a reel-staggering of 4.2 kilowatt-hours of energy per meter each day [5]. Thermoelectric technology has attracted the world's attention with its capability of generating electrical power by converting thermal energy into electrical energy using electrons as its "working fluid" [6]. The thermoelectric generator employs Seebeck and Peltier effect to convert heat directly into electrical energy and vice versa, through the movement of charge carriers induced by a temperature gradient developed across the TEG [7]. TEG is extremely popular in applications of waste heat harvesting as the input thermal power for the TEG's in operating environment is essentially free. The larger the temperature gradient across the TEG, the more electrical power it will generate [8]. A single thermocouple is generally made up from two 'pellets' of semi-conductor material usually made from bismuth-telluride (Bi<sub>2</sub>Te<sub>3</sub>), which is known for its low thermal conductivity and high power factor. The thermoelectric figure of merit ( $Z_T$ ) of thermoelectric generator can be calculated as [9][10]:

$$ZT = \left[ \frac{(S^2 \sigma)}{\lambda} * T \right]$$

where,

S = Seebeck coefficient of TEG module

$\sigma$  = electrical conductivity of TEG module

T = temperature gradient between the TEG faces

$\lambda$  = thermal conductivity of TEG module

After the discussion of Section I which provides the introduction to the proposed research paper then the section II describes the various building blocks of the proposed system. Section III provides the circuit diagram of the proposed system and Section IV illustrates the working of the proposed energy harvesting system. Section V focuses on the performance analysis of the proposed EH system and Section VI focus on the conclusion and various application areas of the proposed work.

## 2. SYSTEM ELUCIDATION

The various building blocks involved in the designing of the proposed hybrid energy harvesting system have been shown in fig. 1 and illustrated below:

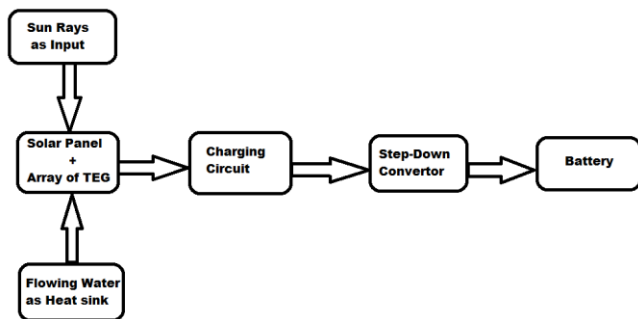

Fig -1: Block Diagram of the proposed system

### 2.1 Solar Panel

The solar panel generates electrical output by converting the incident light rays from solar energy by the phenomenon of photovoltaic energy generation. It acts as an one of the major power source for the hybrid energy harvesting system.

### 2.2 Thermoelectric Generators (TEG's)

These modules are placed at the rear side of the solar panel harnessing the wasted thermal energy and converting the heat energy in useful electrical output by maintaining a proper temperature gradient across its surfaces. The continuous flowing river water is employed as a heat sink for sustaining the temperature difference as required for generation of electrical output.

### 2.3 Polyurethane Foam

The proposed energy harvesting system utilizes polyurethane foam as a part of heat sink because it has the tendency to retain water for longer duration. Also, its porous nature helps in keeping the water cool by convective flow of air through it. Polyurethane foam is made from an aromatic isocyanate, which has been exposed to UV light. This

particular foam piece is approximately four inches wide and 1½ inches thick which is sufficient enough to place array of TEG's on its surface [11].

### 2.4 Charging Circuit

The charging circuit consists of a voltage regulator LM 317T, which helps in maintaining suitable electrical charge. The potentiometer (VR1) employed helps to prevent the back flow of the current from battery to solar panel and array of TEG's.

### 2.5 Voltage Regulator

The voltage regulator (LM7812) is employed in the circuit in order to maintain a constant +12 volt supply to the battery.

### 2.6 Battery

The +12 volt lead acid rechargeable battery is used for storing the electric charge as it has low current discharge capability, which is further used to drive the load.

## 2. SCHEMATIC DIAGRAM

The circuit diagram of the proposed hybrid energy harvesting system is shown in fig. 2 and it has been described below:

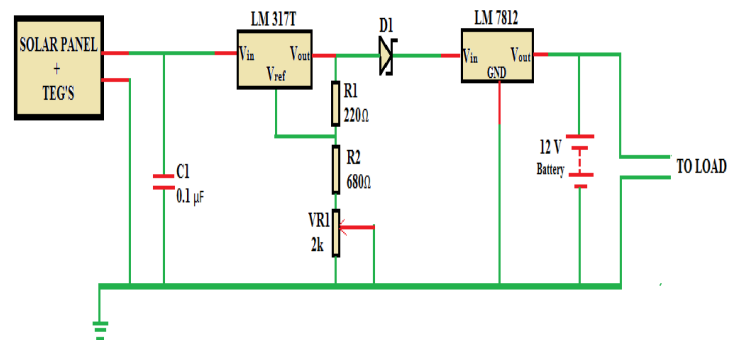

Fig -2: Circuit Diagram of the proposed system

The solar radiations are made to fall on the solar panel which generates electrical output by process of photovoltaic generation. The array of 12 TEG's is employed at the rear side of the solar panel to absorb the wasted thermal energy and also preventing in the rise of the temperature of the solar panel, which results in its fall in the efficiency. The continuous flowing running water has been employed as a suitable heat sink for maintaining temperature gradient across its surfaces. The harnessed voltage from the proposed hybrid energy harvesting system is fed to the charging circuit which comprises of LM 317T, IN5408 Schottky diode (D<sub>1</sub>), by-pass capacitor (C<sub>1</sub>), resistors - R<sub>1</sub>, R<sub>2</sub> and V<sub>R1</sub> for the

efficient charging of +12-volt rechargeable battery. A step down voltage convertor (LM 7812) has been used for the constant supply of +12 volts to the battery.

#### 4. WORKING OF THE PROPOSED SYSTEM

The proposed energy harvesting system consists of a solar panel with thermoelectric generators being placed at its rear side. In this proposed research work, the EH system is simultaneously harvesting both solar energy as well as thermal energy, making it suitable to be termed as a hybrid system. The rear and the top view of the proposed system has been shown in figures 3 and 4.

The solar radiations from the sun are made to be incident on the solar panel, harnessing these light radiations and converting them into electrical output by the phenomenon of photovoltaic energy generation. But in this whole process, the panel gets heated up with these radiations and results in the reduction in its efficiency. The thermoelectric generators employed absorb the heat generated at the back side of the solar panel and is able to generate electrical output if suitable temperature gradient is maintained across the surfaces. These thermal radiations which acts as a heat source, falls on the hot surface of the thermo-electric module so as to raise the temperature of hot surface, whereas the another surface of the thermo-electric module, which is placed on the polyurethane foam, gets cooled down by the continuously flowing water as well as by the convective flow of air through the pores. This results in the generation of an electrical output due to the phenomenon of Seebeck effect. The side view of a single thermos-electric module is shown in the fig. 5.



Fig -3: Rear View of the proposed system

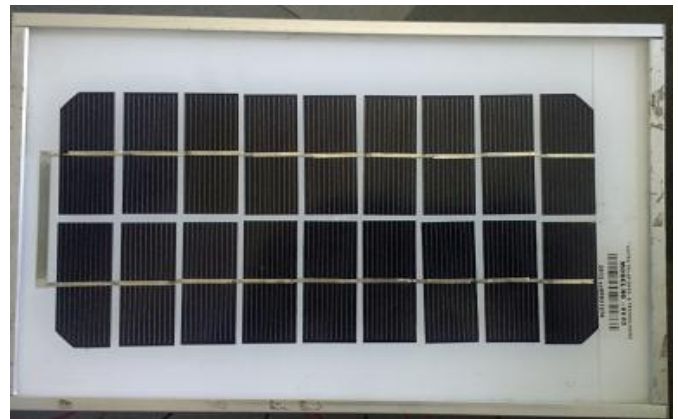

Fig -4: Top View of the proposed system

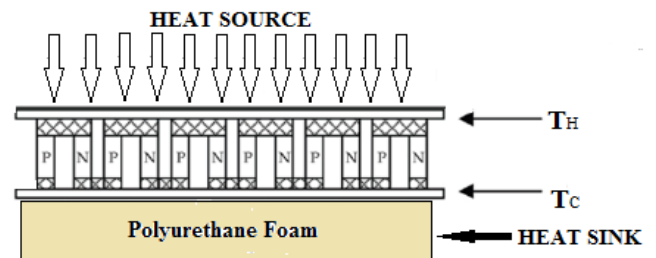

Fig -5: Side View of single thermo-electric module [13]

#### 5. PERFORMANCE ANALYSIS

The performance analysis of the proposed hybrid energy harvesting system is based on the arrangement of thermoelectric generators and the flow of coolant whether stand still or flowing water. The proposed system has been experimentally tested and validated for the satisfactory performance. The Table I shows the average output voltage and current when array of TEG's is placed in still water and it can be concluded that output from the two pairs of 6 TEG's (in series) connected in parallel is approximately twice as much as the other one. The Table II represents the electrical output characteristics shown by the proposed energy harvesting system in flowing water. It can be clearly observed that the former arrangement of TEG's is able to harness more electrical power than compared to later one by 49.7 percent.

The average output power of the proposed hybrid energy harvesting system is calculated by:

$$P_{\text{average}} = V_{\text{average}} \times I_{\text{average}} \tag{1}$$

**Table -1:** Array’s Frame up in Still water

S. No	Array’s Frame up	Average Voltage (in volts)	Average Current (in mA)
1.	Power Output of 2 pairs of 6 TEG’s (in series) connected in parallel (in mW)	4.03	131.32
2.	Power Output of 2 pairs of 6 TEG’s (in parallel) connected in series (in mW)	1.77	150.47

**Table -2:** Array’s Frame up in Flowing water

S. No	Array’s Frame up	Average Voltage (in volts)	Average Current (in mA)	Average Power (in mW)
1.	Power Output of 2 pairs of 6 TEG’s (in series) connected in parallel (in mW)	4.93	182.26	898.54
2.	Power Output of 2 pairs of 6 TEG’s (in parallel) connected in series (in mW)	1.85	133.19	246.4

The efficiency,  $\eta$  of the proposed hybrid energy harvesting system can be computed as below:

$$\text{Efficiency}(\eta) = \frac{P_{1st\ Array} - P_{2nd\ Array}}{P_{1st\ Array}} \times 100 \quad (2)$$

where,

$\eta$  = Efficiency of the proposed hybrid energy harvesting system

$P_{1st\ Array}$  = Average electrical output harvested from the two pairs of six TEG’s (in series) connected in parallel {in mW}

$P_{2nd\ Array}$  = Average electrical output harvested from the two pairs of six TEG’s (in parallel) connected in series {in mW}

$$\text{Efficiency}(\eta) = \frac{529.22 - 266.33}{529.22} \times 100 = 49.7\% \quad (3)$$

Thus, it can be deduced that output obtained from two pairs of six TEG’s (in series) connected in parallel is 49.7 percent more efficient than two pairs of six TEG’s (in parallel) connected in series.

The fig. 6 represents the output power graph harnessed by the thermoelectric modules when employed in arrangement of mixed series and parallel combinations w.r.t temperature and it can be formulated that the two pairs of six TEG’s (in series) in parallel is providing more output than compared

to two pairs of six TEG’s (in parallel) in series. The fig. 7 shows the electrical power harvested by the thermoelectric generators during daytime, that is from 10:00 AM to 6:00 PM and it can be concluded that peak power is obtained around 2:00 PM.

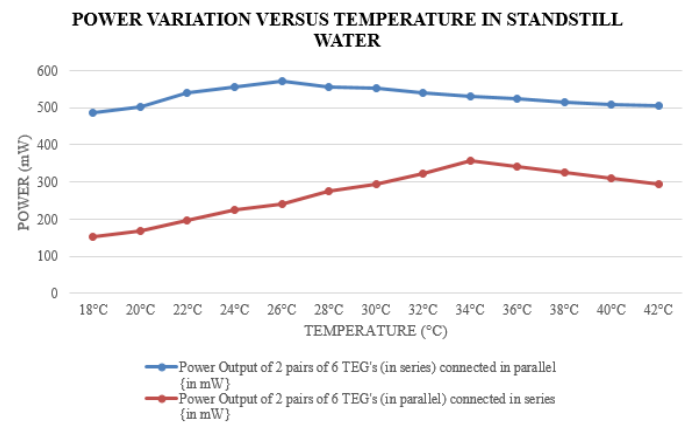

**Chart -1** Power Variation Vs Temperature in Still water

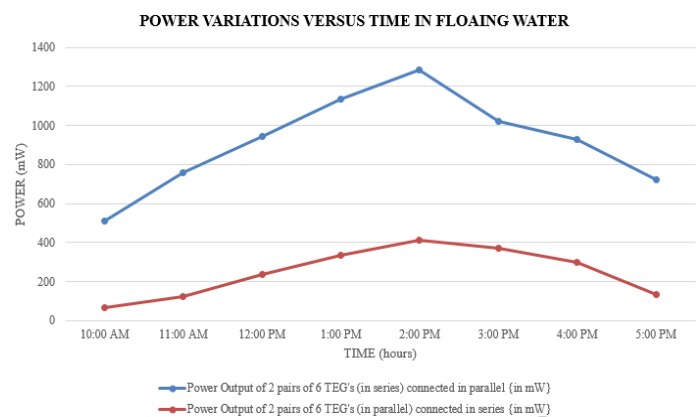

**Chart -2** Power Variation Vs Time In Floating water

## 6. CONCLUSION

The research paper presents a hybrid energy harvesting system employing thermoelectric generators integrated with solar panel. The designed system is able to harness both light as well as thermal energy. The thermoelectric generators are employed at the rear side of the solar panel so as to protect the solar panel from getting heated up and at the same time harvesting the wasted thermal energy. The proposed system has been successfully designed, implemented and experimentally tested for the results. The hybrid energy harvesting system can be employed in dams for keeping check on water levels and generation of electricity for far

away areas. The proposed energy harvesting system is able to harness an electrical output which is effective enough to charge a +12 Volt rechargeable battery.

## ACKNOWLEDGEMENT

We would like to thank Prof. Ekambir Sidhu, Assistant Professor, Punjabi University, Patiala for his worthy guidance, ample support and time to time motivation which helped us in completing this research project.

## REFERENCES

- [1] C. Ugalde, J. Anzurez and I. Lazaro, "Thermoelectric Coolers as Alternative Transducers for Solar Energy Harvesting," Electronics, Robotics and Automotive Mechanics Conference (CERMA), pp. 637-641, 2010.  
doi: 10.1109/CERMA.2010.127
- [2] Arago, N. M., T. M. Amado, and J. W. F. Orillo, "Utilization of cassegrain feed parabolic antenna design in increasing the efficiency of photovoltaic module," 7th IEEE International Conference on Humanoid, Nanotechnology, Information Technology Communication and Control, Environment and Management (HNICEM), 1-6, 2013.
- [3] Yurduseven, O., D. Smith, N. Pearsall, and I. Forbes, "A solar parabolic reflector antenna design for digital satellite communication systems," 8th IEEE IET International Symposium on Communication Systems, Networks and Digital Signal Processing, 1-3, 2012.
- [4] T. Mallik, M. Munna, B. Barua and K. M. Rahman, "A design & implementation of a single axis solar tracker with diffuse reflector," Strategic Technology (IFOST), pp. T. C. Mallick, M. S. Munna, B. Barua and K. M. Rahman, "A design & implementation of a single axis solar tracker w289-293, 2014.  
doi: 10.1109/IFOST.2014.6991124
- [5] S.-U. Khan, T.-u. Rahman and S. Hossain, "A brief study of the prospect of Solar Energy in generation of electricity in Bangladesh," Journal of Selected Areas in Renewable and Sustainable Energy (JRSE), June 2012.
- [6] G. Min and D. M. Rowe, "Conversion Efficiency of Thermoelectric Combustion Systems," IEEE Transactions on Energy Conversion, vol. 22, pp. 528-534, 2007.
- [7] R. Bjork and K. K. Nielsen, "The performance of a combined solar photovoltaic(PV) and thermoelectric generator (TEG) system," Solar Energy, vol. 120, pp. 187-194, 2015.  
doi: 10.1016/j.solener.2015.07.035
- [8] Z. Y. A. Ang, W. L. Woo and E. Mesbahi, "Influence of environmental parameters on the prediction of thermoelectric generator energy generation," 2016 IEEE International Conference on Power and Renewable Energy (ICPRE), Shanghai, China, 2016, pp. 100-104.  
doi: 10.1109/ICPRE.2016.7871181
- [9] R. DM., Thermoelectrics handbook; macro to nano, Boca Raton: CRC/Taylor & Francis, 2006.
- [10] H. Goldsmid, Thermoelectric Refrigeration, New York: Plenum Press, 1964.
- [11] [Online]. Available:  
[https://sailrite.files.wordpress.com/2013/05/2013\\_may\\_29-closefoam.jpg](https://sailrite.files.wordpress.com/2013/05/2013_may_29-closefoam.jpg)
- [12] [Online]. Available:  
<http://www.intechopen.com/books/small-scale-energy-harvesting/three-dimensional-tcad-simulation-of-a-thermoelectric-module-suitable-for-use-in-a-thermoelectric-en>