

E-LICENSE SYSTEM WITH RTO CONTROLE ROOM MANAGEMENT SYSTEM

Mr.C.M.Gaikwad¹, Sumit A. Kokate², Abhijeet T. Ghatage³, Avinash J. Patil⁴

¹Asst professor, Department of E&TC, Sanjeevan Engineering & technology Institute, Panhala, Maharashtra, India.

²³⁴Student, Department of E&TC, Sanjeevan Engineering & technology Institute, Panhala, Maharashtra, India.

ABSTRACT: Driving license system is a very difficult task for the government to monitor. In this project, all the citizens' images will scan and recorded. Whenever a citizen crosses the traffic rules, the police scan his image and can check the license through finger. Again with the help of GPS connected to the RTO control unit the exact location o the traffic police will be located in the control room. The biometric based driving monitoring system is very easy and convenient to monitor.

Keywords: ARM, GPS System, Keypad, GSM modem, Fingerprint module.

1. INTRODUCTION

From the survey it is seen that they implemented a system which is made for verification of driving license. The system consist of ZIGBEE module for transmission or reception of the SMS. The system includes terminal fingerprints acquisition, processing, wireless transmission, fingerprint matching, and verification process. The issues regarding the fake identity have been raised. In order to overcome such problem and to achieve the simple and high real time system, a proposal of low cost and high performance wireless driving license verification function, which provides a new wireless driving license system which will be helpful for traffic police and RTO's.

2. DRAWBACKS IN EXISTING SYSTEM

1. Completed process for getting the license.
2. Time consuming process.
3. We get physical paper or smart card

4. Every time the license paper/smart card need to carry
5. No any Centralized Database for verifying the license so far each state and internally for each district separate offices maintains the database.
6. Corruption chances are there.
7. Problem of physical license/Smart card damaged or lost.

3. BLOCK DAIGRAM

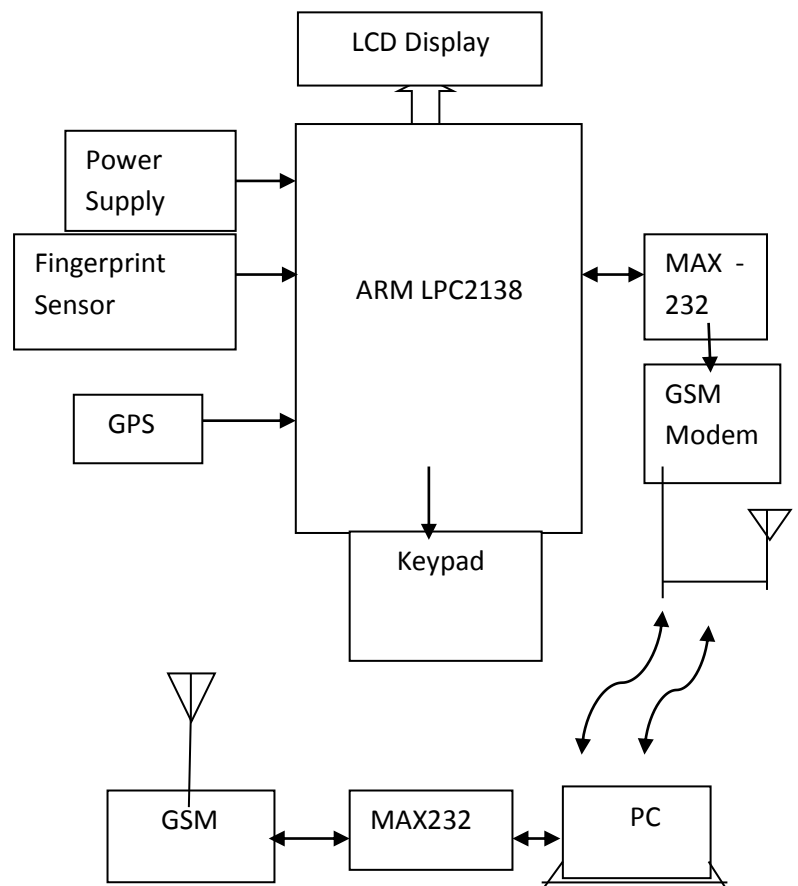

3.1. BLOCK DIAGRAM DISCRPTION

In this Project upper block diagram represents a system which will be carried by traffic police which includes fingerprint module along with GSM module. Whenever traffic police wants to check license of someone he/she will take impressions of which consequences request in terms of message to RTO office. Then details of person will be provided by RTO office to traffic police so that he can check for valid driver. With this system control room will be able to track the location of the Traffic police and can make an effective communication.

There are two sections in this project. First transmitting and other one is receiving.

3.2 TRANSMITTING SECTION

In transmitting section take the fingerprint of the driver. Then the output of fingerprint module will be given to the ARM. GSM is connected to arm using RS232. Then through GSM the data is in the form of hexadecimal is transmitted to the base station. Keypad is interfaced with ARM. Keypad is programmed in such a way that every key is given certain function. Key 1 is pressed then it takes fingerprints . Key 2 for drunk and drive likewise various function are given. The receiver will check for the similar data in database. If it matches the data stored then it will send back the message that license is "VALID". If the fingerprints does not match then it sends back the message as "NOT VALID" to the transmitter. E-LICENSE Again the location of the RTO will be send to the RTO server.

3.3 RECEIVING SECTION

At the receiver side of the system key part is RTO server in which the entire database of all the valid license holders along with fingerprint stored. All the command message of

the fingerprint data will be receive by the GSM at the receiving side. This string will be compare with data stored at the database . And for the valid fingerprint the license details are sent to the RTO unit.

In this System, ARM LPC2148 is used because it has two inbuilt input output ports which are required in this system. Also LPC2148 operates on 3.3v, so power consumption is also less. The GSM module is used in this system which is advanced technique than Bluetooth and ZIGBEE. Fingerprints module R305 is used because it is easily interfaced with the ARM LPC2148 and easily available.

It represents a system which includes fingerprints module along with GSM module. Whenever traffic police wants to check license of someone he/she will take impressions of thumb which sends the request in terms of message to RTO office. Then details of person will be provided by RTO office to traffic police so that he can check for valid driver. Fingerprint module and GSM are interfaced using ARM. ARM will also be interfaced with keypad and LCD display.

4. HARDWARE DESIGN

4.1. ARM LPC2138

The LPC2138 is based on a 16/32 bit ARM7TDMI-STM CPU with real time emulation and embedded trace support, with 512 kilobytes (KB) of embedded high speed flash memory. A 128- bit code wide internal memory interface and unique accelerator architecture enable 32-bit code execution at maximum clock rate.

4.2. FINGERPRINT SENSOR R305

This is a fingerprint sensor module with TTL UART interface for direct connection to ARM or to PC through MAX232 / USB-Serial adapter The user can store the fingerprint data in the module and can configure it in 1:1

or 1:N mode for identifying the person. The FP module can directly interface with ARM. A level converter (like MAX232) is required for interfacing with PC serial Port

4.3. GPS

This design adapts the current leading GPS technology. The receiver has a Serial Communication facility which is used to interface with the external device like PC or ARM controller. The antenna of the GPS receiver receives the signals, transfer the data to ARM controller's serial communication pins for further processing and location identification. The processed data can be transferred to the GSM through serial communication and to the owner

4.4. GSM

Messages sent by the user are received by the GSM module. Micro controller will play important role in sending and receiving commands to GPS. Micro Controller extracts the location name and send the same to the GSM via serial communication. Micro controller will find location and send details to GSM Mobile using serial communication system.

5. SOFTWARE DESIGN

Visual Basic

Visual basic is a third-generation event-driven programming language. The companies will create a server with the help of visual basic software and SMS access for its database.



6. FLOWCHART

6.1 RTO SERVER SIDE

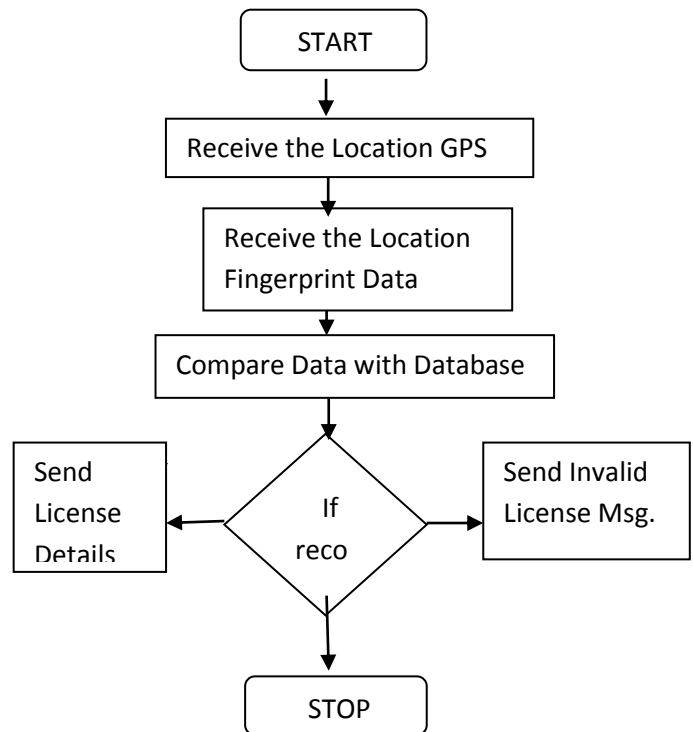

Fig. Flowchart 1

6.2 RTO UNIT TRANSMITTER SIDE

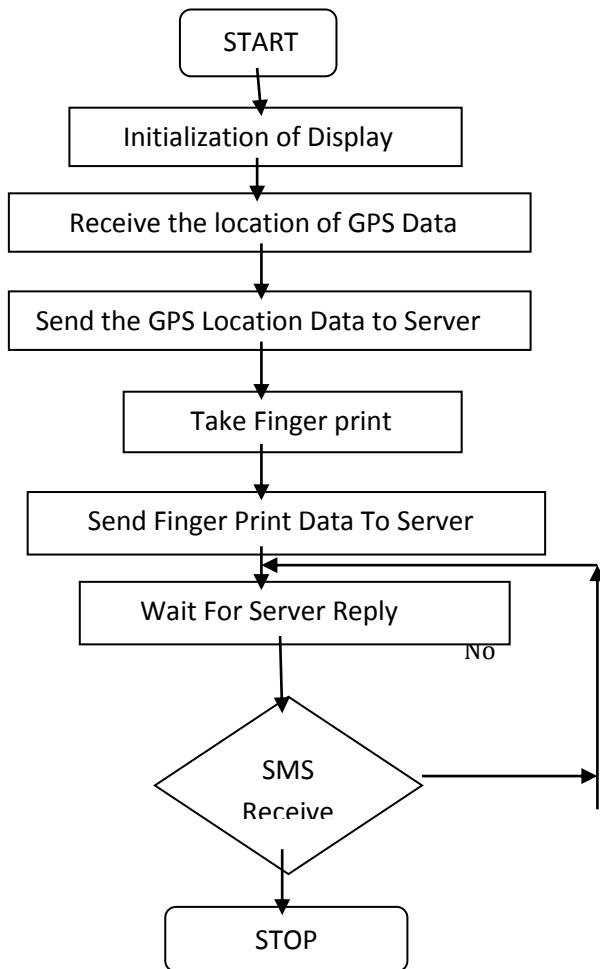
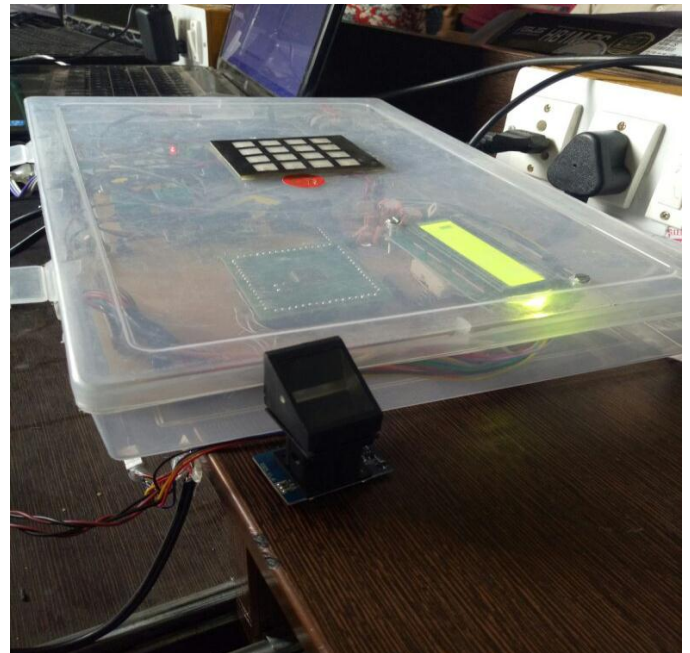
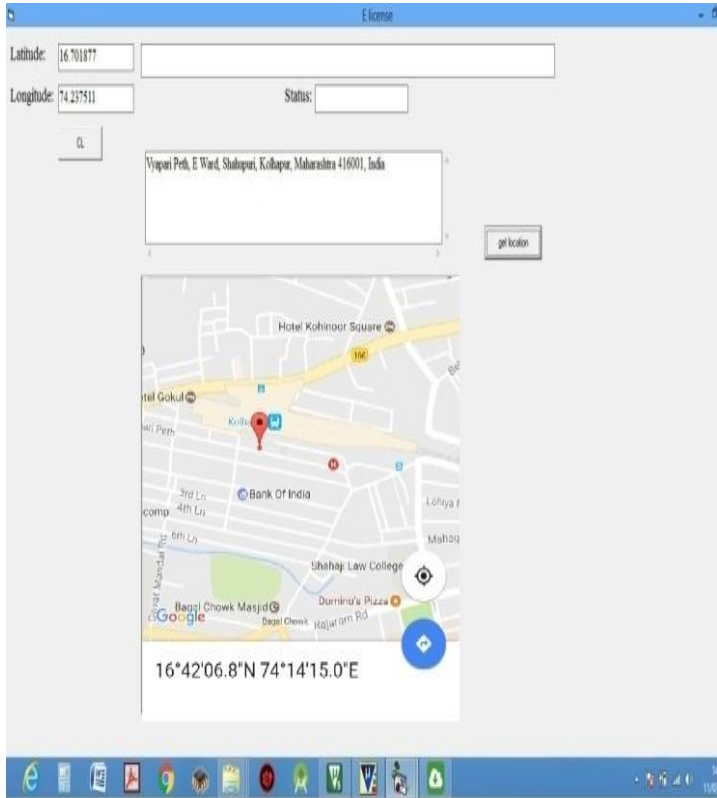

Fig. Flowchart 2

7. RESULT

The RTO control room will create a server with the help of visual basic software and SMS access for its database. Using Fingerprint Module, device takes users fingerprints and sends to the server. These fingerprints scan to the server and sends the signal to the device and device shows "Valid" or "Invalid". The Location of the device is shown in Google Maps. The results snapshot are shown in below.





8. CONCLUSION

E-License system will be the best invention which will definitely helps in maintaining the centralized national database and again as the finger will act as a license it's not required to carry the license. Its also helps in reducing the corruption.

9. ACKNOWLEDEMENT

We express our sincere gratitude to our institute Sanjeevan engineering & technology institute, Panhala. We

are thankful to the almighty for giving us the opportunity for carrying out this work under the guidance of **Mr.C.M.Gaikwad Sir** His encouragement and teaching have helped us grow intellectually in a truly efficient manner.

10. REFERENCES

- [1] National Science and Technology Council Subcommittee on Biometrics Identity Management Biometrics in Government Post-9/11:Advancing Science, Enhancing Operation, Aug 2008.
- [2]A.K.Jain. P.Flynn and A.A.Ross, eds., Handbook of Biometrics, Springer, 2007.
- [3]H.C.Lee and R.EGaensslen,eds., advances in Fingerprint Technology, 2nd,CRC press 2001.
- [4]J.Feng, "Combining Minutiae Descriptors for Fingerprint Matching," Pattern Recognition, Jan.2008,pp-342-352.
- [5]A.A.Ross, K.Nandkumar, and A.K. Jain, Handbook of Multybiometrics, Springer,2006.