

# Real Time Smart City Garbage Collection and Monitoring System Using GSM and GPS

Sonal Chakole<sup>1</sup>, Priya Khadse<sup>2</sup>, Shruti Shinganjude<sup>3</sup>, Prajakta Pimple<sup>4</sup>, Snehal Shahane<sup>5</sup>, Shweta Mokhale<sup>6</sup>

<sup>1</sup>Professor, Dept. Of Computer Science & Engineering, PJLCE, Maharashtra, India

<sup>23456</sup>Student, Dept. Of Computer Science & Engineering, PJLCE, Maharashtra, India

\*\*\*

**Abstract:** In past few years, the growth of cities is rapidly going high. And in coming few years the cities will become developed and smart one. But, the smart city is incomplete without a smart garbage management system. To achieve this, Government of India is also running a campaign. With the existing system, in most of the areas municipality workers do not visit daily to collect garbage which results in spread of diseases.

This project is designed for the effective collection of garbage using Embedded System. The main motto of this application is to inform the officials of municipality, when this garbage reaches extreme level, which will sense by using ultrasonic sensor.

**Keywords-** Smart City, Garbage Management, AT89S52 Microcontroller, Load Cell, GSM, GPS.

## 1. INTRODUCTION

In Day to Day life, we see the pictures of garbage bins being overflow and all the garbage spills out resulting in pollution. This also increases number of infection as large number of pest and mosquitoes breed on it. Hence our problem statement is to plan a System Based on AT89S52 for collecting the garbage from a particular region – the region whose public Garbage Bins are overflowing with previous concern. Solid waste management is a big challenge in urban areas for most of the countries throughout the world. An efficient waste management for uphold a safe and green environment as there are rising all kinds of waste disposal. There are many technologies are used for waste collection as well as for well managed recycling. In this project, we have introduced an integrated system pooled with an integrated system of Global Positioning System (GPS) and Global System for Mobile Communication (GSM). The sensors would be placed in the common garbage bins sited on the public places. When the garbage reaches the level of the sensor, then that signal will be given to AT89S52 Controller. The controller will gives signal to the driver of garbage collection truck as to which garbage bin is completely filled and desires urgent attention. AT89S52 will give indication by sending SMS using GSM technology. Whenever the garbage is full

information can be send to the concerned authority to clean the bin.

## 2. LITERATURE SURVEY

The garbage management in cities has to be effectively and efficiently implemented. The variety of proposals were put self-assured and some of them already implemented. But it cannot be considered as an effective one. So a survey was done among different proposals and this survey includes survey among different methods for smart garbage management in cities using IoT. The Smart Garbage Management in Smart Cities using IoT proposed a method. The level of garbage in the dustbins is detected with the aid of ultrasonic sensors system, and communicated to the authoritative control room through GSM system.

AT89S52 microcontroller is used to interface the sensor system with GSM system. Sensors are use to monitor the desired information related to the garbage for different selected locations. This will help to manage the garbage collection efficiently. Level detector consists of sensors which are used to detect the level of the garbage in the dustbin. The output of level detector is given to microcontroller. Two sensors are used to indicate the different levels of the amount of the garbage collected in the dustbin which is placed in public area. When the dustbin is filled up to the highest level, Distance sensor sense the level of garbage. This output is given to microcontroller to send the message to the Control room via GSM module.

## 3. PROPOSED WORK

Now, let us see the particulars of the various building blocks of the hardware of an embedded system. As shown in Fig. the building blocks are:

### 3.1. Memory:

The memory is categorized as Random Access Memory (RAM) and Read Only Memory (ROM). The stuffing of the RAM will be erased if power is switched off to the chip, while ROM retains the contents even if the power is switched off. So, the firmware is saving in the ROM. When power is switched on, the processor interpret the ROM. The program is executed.

### 3.2. Input devices:

Unlike the desktops, the input devices to an embedded system have very restricted capability. To hand will be no keyboard or a mouse, and hence interrelate with the embedded system is not easy task. Many embedded systems will have a small keypad-you press one key to give a particular command. A keypad could be used to input only the digits. Many embedded systems used in process control do not have any input device for user dealings; they take inputs from sensors or transducers to produce electrical signals that are in turn fed to other systems.

### 3.3. Output devices:

The output devices of the embedded systems also have very limited potential. Several embedded systems will have a few Light Emitting Diodes (LEDs) to indicate the health status of the system modules, or for visual indication of alarms. A small Liquid Crystal Display (LCD) may also be used to display some significant parameters.

### General Description:

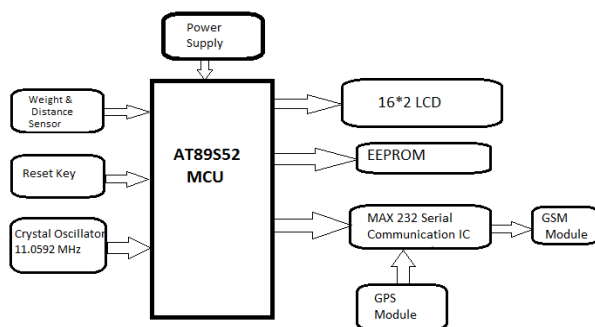

Fig (a): Flow of System

### Power Supply

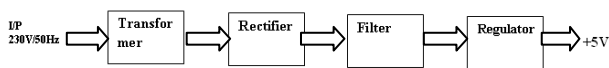

Fig (b): Power Supply

## 4. EXPERIMENTAL SETUP:

### 4.1. Microcontroller:

The microcontroller used in this project is AT89S52. Atmel Corporation introduced this 89S52 microcontroller. This microcontroller fit in to 8052 family unit. This microcontroller has 128 bytes of RAM, 4K bytes of on-chip ROM, two timers, one serial port and four ports all on a single chip. AT89S52 is Flash type 8052. The present project

is put into practice on Keil Uvision. In direct to program the device; Proload tool has been used to burn the program onto the microcontroller.

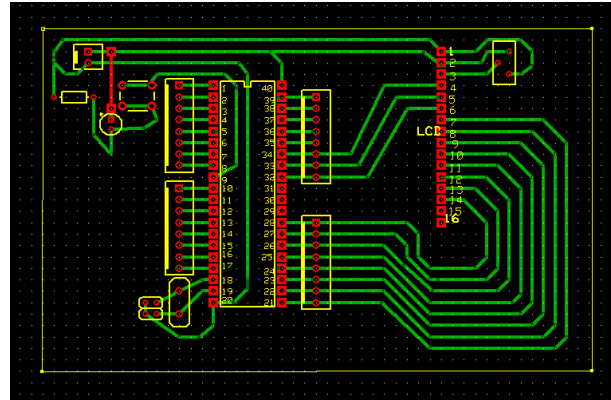

### 4.2. Max 232 IC:

Max232 IC is a particular circuit which makes standards required by RS232 standards. This IC impart best noise rejection and very reliable against discharge sand short circuits. MAX232 IC chips are commonly referred to as line drivers.

### 4.3. Buzzer:

The buzzer subsystem produces an audible tone when powered.

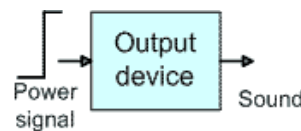

### 4.4. Global Positioning System (GPS)

The Global Positioning System (GPS) is a U.S. space-based global direction-finding satellite system. It provides consistent positioning, navigation, and timing services to worldwide users on a continuous basis in all weather, day and night, anywhere on or close to the Earth which has an unhindered view of four or more GPS satellites. GPS is ready up of three segments: Space, Control and User. The Space Segment is composed of 24 to 32 satellites in Medium Earth Orbit and also includes the boosters necessary to launch them into orbit. The Control Segment is self-possessed of a Master Control Station, an Alternate Master Control Station, and a host of devoted and shared Ground Antennas and Monitor Stations. The User Segment is collected of hundreds of thousands of U.S.



and similar military users of the secure GPS Precise Positioning Service, and tens of millions of civil, business-related and scientific users of the Standard Positioning Service (GPS navigation devices). GPS satellites relay signals from space that GPS receivers make use of three-dimensional location (latitude, longitude, and altitude) plus accurate time.

#### 4.5. Global System for Mobile Communication (GSM)

Global System for Mobile Communication (GSM) is a second generation cellular standard urbanized to cater voice services and data delivery using digital modulation.



#### 4.6. EEPROM:

In the devise of all microprocessors-based systems, semiconductor memories are used as primary storage for code and data. Semiconductor memories are attached directly to the CPU and these are the memory that the CPU first asks for information (code and data). For this reason, semiconductor memories are occasionally referred to as primary memory.

#### 4.7. Liquid Crystal Display (LCD):

LCD stands for Liquid Crystal Display. LCD is finding wider use replacing LEDs (seven segment LEDs or other multi segment LEDs) because of the subsequent reasons: The fading prices of LCDs, the ability to display numbers, characters and graphics. This is in contrast to LEDs, which are restricted to numbers and a few characters. Incorporation of a refreshing controller into the LCD, thereby relieving the CPU of the task of refreshing the LCD. In contrast, the LED must be revived by the CPU to keep displaying the data. Ease of programming for characters and graphics. These components are focused for being used with the microcontrollers, which means that they cannot be activated by standard IC circuits.

#### 4.8. Sensor Used:

##### 8.1. Distance Sensor

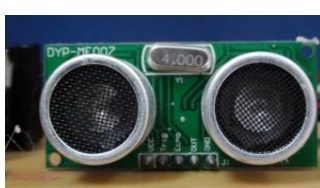

##### 8.2. Weight Sensor



## 5. OUTPUT

### 5.1. Overview of System

Following picture depicting the overall view of the implemented system.



### 5.2. Messages Received

#### 2.1 Received Message of Garbage overweight

The message is received along with the location (i.e. longitude and latitude values) on municipal authority's mobile.

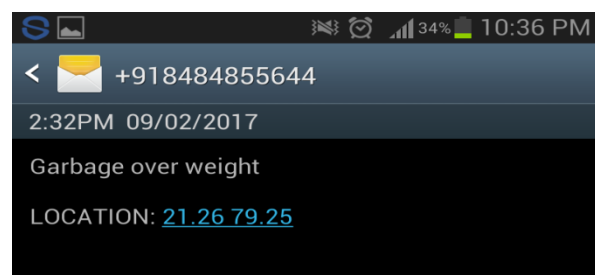

#### 5.2. Received Message of Garbage 90% full

The message is received along with the location (i.e. longitude and latitude values) on municipal authority's mobile.

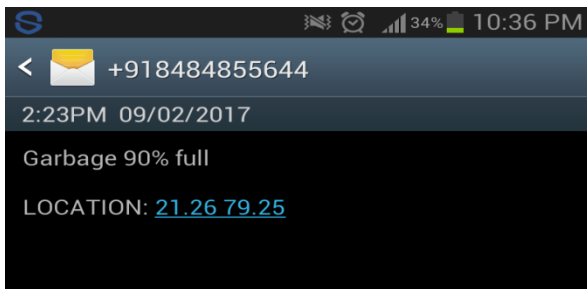

## 6. CONCLUSION

In past few years, the growth of cities is rapidly going high. And in coming few years the cities would become developed and smart one. But, the smart city is incomplete without a smart garbage management system. So, we have designed a system for proper management of garbage. In this project we have studied and implemented concept of Smart City with the help GPS and GSM. This system assures the cleaning of dustbin soon when the garbage level reaches its maximum threshold. The Embedded C technique is enhancing the system to achieve the desired result. We have successfully implemented and tested the proposed system. From this paper, we believe that people get encouraged to build some other systems using different techniques and help nation to become diseases free. Also we believe, encouragement from the side of government can transform the prototype into a product.

## ACKNOWLEDGMENT

The whole process of this project which is presented in this paper was such a difficult task. But the guidance of lecturers made it easy. So, precious thanks to them to make this implementation successful one.

## REFERENCES

- [1] Monika K. A., Nikitha Rao, Prapulla S. B., Shobha G., " Smart Dustbin-An Efficient Garbage Monitoring System", International journal of Scientific and Engineering Research, vol 6, Issue no. 6, pp 7113- 7116.
- [2] Narayan Sharma, Nirman Singha, Tanmoy Dutta, " Smart Bin Implementation For Smart City" International journal of Scientific and Engineering Research, vol 6, Issue no. 9,pp 787-789.
- [3] Prakash,Prabhu,"IoT Based Waste Management for Smart City" International journal of Innovative Research Computer and Communication Engineering, vol 4, Issue no. 2,pp 1267- 1274.

- [4] Pranjal Lokhande,M. D. Pawar," Garbage Collection Management System" International journal of Engineering and Computer Science", vol 5, Issue no. 11,pp 18800- 18805.
- [5] Acharya Kiran Umesh,Jason Vinod D'souza,Johan Roy Tauro, Jeaffry Joseph, "Smart Waste Management System"
- [6] www.howstuffworks.com.
- [7] www.answers.com
- [8] www.WineYard.in
- [9] Electronics for you
- [10] Elektrikindia
- [11] Go Wireless

\*\*\*\*\*