

HYBRID COOLER

Dipali Warhade, Kanchan Gujarmare, Priyanka Gadpale, Sunayana Somkuwar

Department of Electrical, Vidya Niketan College of Engineering & Tech,

Rashtrasant Tukdoji Maharaj University, Nagpur

INTRODUCTION

Solar energy is radiant light and heat from the Sun that is harnessed using a range of ever-evolving technologies such as solar heating, photovoltaics, solar thermal energy, solar architecture, molten salt power plants and artificial photosynthesis. The human body can be considered as thermal machine with 20% thermal efficiency. The remaining 80% heat must be disposed off from the body to the surroundings otherwise accumulation of heat results and causes discomfort. The human body works best at a particular body temperature like any other machine but cannot tolerate wide range of variation in environmental temperature like thermodynamic machines.

AIMS AND OBJECTIVES

Here will a solar panel which will give the output to the battery but sometimes there might be an increase in the intensity of the sunlight so there is a possibility of having damage to the battery. So here controller circuit will be used to provide constant voltage to the battery even when the intensity of the sunlight is high because when the intensity is high the solar panel will give double the voltage than it is required by the battery. This circuit will run pump and there will be filters attached to the pump. A charge controller, charge regulator or battery regulator limits the rate at which currents added to or drawn from electric batteries.

It prevents overcharging and may prevent against overvoltage, which can reduce battery performance or lifespan, and may pose a safety risk. It may also prevent completely draining ("deep discharging") a battery, or perform controlled discharges, depending on the battery technology, to protect battery life. The terms "charge controller" or "charge regulator" may refer to either a stand-alone device, or to control circuitry integrated within a battery pack, battery-powered device, or battery recharger.

NEED OF SOLAR COOLER

Human beings give off heat, around an average of 100 kcal per hour per person, due to what is known as 'metabolism'.

The temperature mechanism within the human body maintains a body temperature of around 36.9 degree C (98.4 degree F). But the skin temperature varies according to the surrounding temperature and relative humidity. Fuel deposit in the will soon deplete by the end of 2020, fuel scarcity will be maximum. Country like India may not have the chance to use petroleum products. Keeping this dangerous situation in mind we tried to make use of non-pollutant natural resource of petrol energy.

DIRECT METHOD OF UTILIZATION OF SOLAR ENERGY

The most useful way of harnessing solar energy is by directly converting it into electricity by means of solar photo-voltaic cells. Sunshine is incident on Solar cells, in this system of energy Conversion that is direct conversion of solar radiation into electricity.

In the stage of conversion into thermodynamic form is absent. The photo-voltaic effect is defined as the generation of an electromotive force as a result of the absorption of ionizing radiation. Energy conversion devices, which are used to convert sunlight to electricity by use of the photo-voltaic effect, are called solar cells.

PHOTOVOLTAIC PRINCIPLES

The photo-voltaic effect can be observed in nature in a variety of materials that have shown that the best performance in sunlight is the semiconductors as stated above. When photons from the sun are absorbed in a semiconductor, that create free electrons with higher energies than the created there must be an electric field to induce these higher energy electrons to flow out of the semiconductor to do useful work. A junction of materials, which have different electrical properties, provides the electric field in most solar cells.

BLOCK DIAGRAM

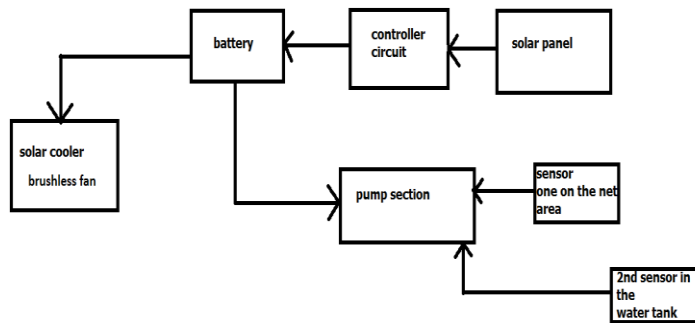

FIG.SOLAR COOLER

PARAMETERS DISCRIPTION

BRUSHLESS DC FAN

Brushless dc fan are usually available at 3 nominal voltages.12 v,24 v and 48v.if the selected which will give the exact performance required.Because the speed and airflow of a typical DC fan is proportional to the voltage supplied to desired airflow.The voltage range that may be applied to the fan to assured satisfactory operation is depend 12 -56 v for 48 units.

CONTROLLER CIRCUIT

Controller circuit can be constructed of discrete components connected by individual pieces of wire, but today it is much more common to create interconnection by photolithographic technique.An electronic controller circuit can usually be categorized as an analog circuit and digital circuit or a mixed-signal circuit.

SOLAR PANEL

Solar panel reference to a panel design to absorb the sun rays as a source of energy for generating electricity. A photovoltaic module is package assembly of typically 6*10 solar cells. Solar photovoltaic Panel constitute the solar array of photovoltaic system that generate and supplies solar electricity in commercial and residential.



WATER PUMP

Some homes have a large water tank on high, then Pumping up the put on hold. When you want to use, just to turn on the tap at the bottom. It does not require all time electricity and also high water pressure. But over here we will run the cooler pump on solar energy.Automatic pump controller circuit can automatically switch ON and OFF the domestic the main advantage of this cooler pump controller circuit is that it automatically controls the water pump without any user interaction.No human effort is required for switching on and off the pump of cooler every time for saving the water. Controller has been provided with two flip flops for the two sensor probes and each two probes to probes to monitor its status.Controller has been provided with two flip flops for the two sensor probes and each two probes to probes to monitor its status.

WORKING

Through the solar panel battery will be charged.The pump controller circuit will run on battery and the sensors attached will sense the level of water in the tank and the motor pump will be on as the level of water goes down and the pump will be off when the tank level is full.The dc fan will continuously run on battery.This will give effective solar energy on the panel and it will boost the charging the battery.The charge controller circuit will protect the battery from damage and also the solar panel.

OBJECTIVE OF THE PROJECT

To make aware of non conventional energy sources to reduce environmental pollutions. This product preferably suitable for villages, because they face lot of power cut problems in summer (around 12 to 14 hrs in day). And for offices and schools which runs in day to which save energy. As air-conditioning and refrigeration consumes more power and mainly cost of refrigerating and air conditioning products are very high. So would like develop product which runs by solar energy and provide cooling effect for house hold food items at lower cost.

WORKING OF SOLAR CHARGE CONTROLLER

The two diodes are attached to positive line to convert ac volt to dc if any, solar gets damaged or its chemical properties is not good the solar panel will supply impure dc so for removing impurity the diodes are attached. Pure positive dc volt will be supplied.

The r1 resistance will supply voltage to the 555 timer ic and ic will be on there is ac1 capacitor attached that will purify the volt and will supply it to gnd that means the pure negative voltage will be there.

Another part there is 8 volt zener diode attached that means the voltage coming from the main supply the zener diode will bypass the voltage to gnd not more 8 volt that is why the zener diode of 8 volt is connected to gnd.

The 2 nd no. Pin of 555 timers ic is triggering pin that will pass the timing pulse to the gnd and the ceramic capacitor is attached.

The base of transistor the r4 resistance is attached for switching on the transistor.

The next zener diode is attached so that positive voltage coming from vcc it should not be more than 8 volt dc and the single 4007 no. Diode is attached.

During night time the battery will discharge and the battery will supply the reverse volt towards the solar panel so for stopping the reverse volt.

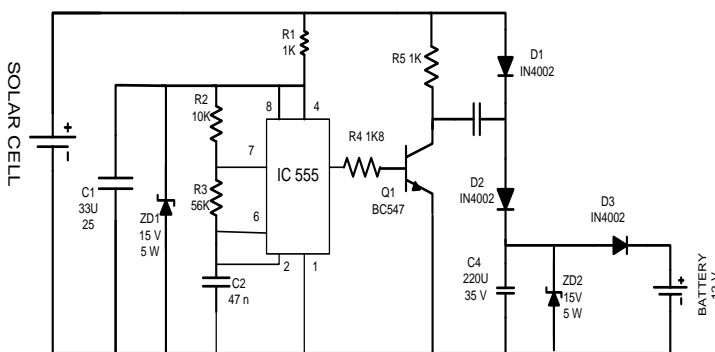

Automatic pump on off system

There will be sensor wires attached on the bottom of the cooler water tank and another sensor will be attached at the upper portion of the net of the cooler.

The upper sensor will detect that the net of the cooler is dry then the pump will automatically on and it will be in the same position till the net is filled with water or wet and it will soon switch off the pump. The high speed brush less fan DC volt denoting in block diagram as solar cooler is also installed.

Advantages

- This process of on off will work continuously.
- No need for manual switching.
- This process or system will save water instead of keeping the pump in on mode till the water is over.
- This system will help in saving the water as it will work on timely condition as detected by the sensor.
- This will also save electricity from the battery as this system is also running on solar energy.

DISADVANTAGE

- Installation cost will be high but one time.

APPLICATIONS

- Will be used as summer ac.
- Summer cooler.

FUTURE SCOPE

Solar tracking function can be installed where the solar panel can be moved from left to right as per the suns direction. This circuit can improved by installing the high quality and industrial, based components for increasing the solar panel capacity and also for running the high current rating components so that the desert cooler or for the industrial application solar based ducting mechanism can be run easily.

CONCLUSION

So as comparing the cost of this product with the existing products in the market is, solar Product appeals better and affordable by Common people. This solar product perfectly Suits for villages, schools and offices and thus Prevention from the power cut problems. It comprises of many attractive features such as Usage of solar energy, cooler and cooling cabin At lower cost. The above method is eco friendly And natural, electricity savers. Durability of our product is more thus Minimizing the cost. No electricity is spent so this product saves the energy and saves Environment from getting polluted.

REFERENCES

1. Alosaimy A S (2013), "Application of Evaporative Air Coolers Coupled with Solar Water Heater for Dehumidification of Indoor Air", International Journal of Mechanical & Mechatronics Engineering, Vol. 13, No. 01, pp. 60-68.
2. Arora S C and Domkundwar S (1988), "A Course in Power Plant Engineering", A Text Book.
3. Farhan Khmamas (2012), "Improving the Environmental Cooling for AirCoolers by Using the Indirect-Cooling Method", ARPN Journal of Engineering and Applied Sciences, Vol. 5, No. 2, pp. 66-73.
4. SERI (1982), "Basic Photovoltaic Principles and Methods", SERI/SP-290-1448, Solar Information Module 6213.
5. Srinivas Reddy B and Hemachandra Reddy K (2007), "Thermal Engineering Data Hand Book", I K International Publishing House.