

# Fractional Frequency Transmission System

Somesh Sadalge<sup>1</sup>, Suraj Bhoskar<sup>2</sup>, Amol Chavan<sup>3</sup>, Rohit Kabaj<sup>4</sup>, P. M. Maskar<sup>5</sup>

<sup>1234</sup>Students, Electrical, Sanjay Ghodawat institute, Atigre, India

<sup>5</sup>Professor, Dept. of Electrical Engineering, Sanjay Ghodawat institute, Maharashtra, India

\*\*\*

**Abstract** -The fractional frequency transmission system (FFTS) is a newly developing concept in power transmission system. In this system, electrical power is transmitted at a reduced frequency (One third of the rated frequency). This approach would be effective in long- distance transmission system of electrical power. Transmitting power at a reduced frequency reduces the electrical length of the transmission line (i.e., more amount of electrical power can be transmitted using the same length of the line at reduced frequency than at rated frequency). This paper introduces the basic concept of FFTS and primary results. The primary objective of this paper is design of frequency converter that is required at each end of the transmission line in order to change the frequency. The experiment uses cycloconverter as a frequency changer, which is used at the sending end to step down the frequency to 50/3Hz. Similarly, at the receiving end another frequency converter is used to step- up the frequency back to 50Hz. The FFTS approach proposes new strategy for expanding the transmission capacity.

**Key Words:** Frequency converter, Fractional frequency Transmission System, Transmission System.

## 1. INTRODUCTION

In the history of the ac transmission system, increasing distance and capacity mainly depends on raising voltage rating of transmission lines. Now day, the highest voltage level of the ac power transmission system in operation is 750 kV. To further upgrade, the voltage level encounters difficulties of material and environmental issues. The transmission and distribution losses in India currently stand at 27% of the total power is generated. Another method i.e., employed to increase the transmission capacity is the high voltage DC (HVDC) transmission system. A HVDC transmits DC power at a very high voltage level. However, at the generation is in AC, it has to employ current converters at transmitting and the receiving ends and these current converters are very expensive device. Apart from that, up to now the HVDC practices have been limited to the point-to-point transmission system. It is difficult to operate a multi- terminal HVDC system. In 1994, the fractional frequency transmission system was developed, which uses lower frequency (50/3 Hz) to reduce the electrical length of the ac transmission line, and thus, its transmission capacity can be increased.

This paper presents the experimental installation of FFTS and primary experimental results. The experiment uses cycloconverter as a frequency changer is used at the sending end to step the frequency down to 50/3Hz. Similarly, at the receiving end another frequency tripler is used to step-up the frequency back to 50Hz.[13] Thus, a another FACTS device is successfully established in this experiment.

## 2. METHODOLOGY

Power transmission using FFTS involves frequency changes at four stages: -

1. In such a system, electrical power is transmitted at a reduced frequency (One third of the rated frequency=50/3 Hz).
  2. Transmitting power at a reduced frequency reduces the electrical length of the transmission line (i.e., more amount of power can be transmitted using the same length of the line at reduced frequency than at rated frequency).
  3. At the sending end, cycloconverter is use for reducing frequency.
  4. Similarly, at the sending end frequency tripler is use for converting frequency back to 50 Hz before feeding to utility grid.
- The basic schematic diagram of FFTS is as shown below:-

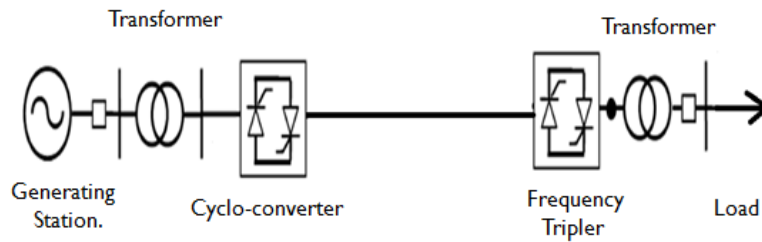

Figure 1.Schematic Diagram of FFTS.

In the schematic diagram it is assumed that the hydro-generator is generating power at frequency of 50Hz. Using a transformer the voltage of the generator is stepped up to a suitable value. At sending end by using cycloconverter we are stepping down the frequency from 50Hz to 50/3Hz. At the receiver end, for stepping up the frequency there is the frequency tripler circuit which may be a saturable transformer or the power electronic AC-AC frequency changer, such as a cycloconverter. For the transformer, since the electric power that has to be stepped up with low frequency, the core section area and the coil turn must be increased. Therefore, the cost of the transformer in FFTS is more than that of the conventional transformer. The conventional transmission line can be used in FFTS without any change.

1) **CONCEPT OF FFTS:**

The phenomenon of FFTS can be established by using the following two concepts-

There are three factors limiting the transmission system capacity of a line-

Thermal limit, Stability Limit, Voltage drop Limit (Voltage Regulation). For long-distance ac transmission, the thermal limitation is not a significant impediment. Its load ability mainly depends on the stability and voltage drop limit. The stability limit of an ac transmission line can be approximately evaluated by-

$$P = \frac{V^2}{X}$$

Where,

V is the normal voltage

X is the reactance of the transmission line.

From the above equation we see that, the transmission power is directly proportional to the square of the voltage level and inversely proportional to the reactance in the transmission line.

The voltage drop ΔV can be evaluated by-

$$\Delta V = \frac{Q}{V^2} \times 100$$

Where,

Q is the reactive power flow of transmission line.

Thus, the voltage drop is inversely proportional to the square of voltage and directly proportional to the reactance of the transmission line. Hence, in order to boost the transmission capability, either the voltage level can be increased or the reactance of the transmission line can be reduced.

The reactance is directly proportional to frequency and is given by-

$$X = 2\pi fL$$

Where,

L is the total inductance of transmission line, calculated by multiplying the inductance per kilometer of the line by length of the line. The inductance per length is calculated based on the type of conductor used. Hence, decreasing the frequency can proportionally to increase transmission capability. Thus FFTS uses reduced frequency to reduce reactance of the transmission system. For instance, when the 50 Hz frequency is reduced by three times, then theoretically, transmission system capability increases.

### 3. HARDWARE DESIGN

#### 1. Cycloconverter-

The circuit uses standard power supply comprising of a step down transformer from 230V to 12V and a bridge rectifier that delivers pulsating dc which is filtered by an electrolytic capacitor. The filtered dc being, IC LM7805 is used to get 5V DC constant voltage level. The regulated 5V DC voltage is further filtered by small capacitor of 10µF for any noise occurred by the circuit. One LED is connected of this 5V in series with a current limiting resistor of 330Ω to the ground. i.e., negative voltage to indicate 5V power supply availability. The unregulated 12V point is used for other applications and when required.

Zero voltage cross detection means the supply voltage profile that passes through zero voltage level for every 10msec of a 20msec cycle. We are using 50Hz ac signal, the cycle time period is 20msec ( $T=1/F=1/50=20\text{msec}$ ) in which, for every half cycle (i.e. 10ms) we have to get zero signal. Here Op-amp is used as comparator circuit. The principle of a comparator is that when non-inverting terminal is greater than the inverting terminal then the output is logically high (supply voltage). The output of this comparator is fed to the inverting terminal of another comparator circuit. Thus we get Zero Voltage Reference (ZVR) detection. This ZVR is then used as input pulses to microcontroller. The output of microcontroller is fed to thyristor SCR's used in full bridge are in anti-parallel with another set of 4 SCR's as shown in the block diagram. Triggering pulses so generated by the MC as per the program written provides input condition to the Opto-coupler that drive the respective SCR. For F/3 the conduction takes place for 30ms in the 1st bridge and another 30ms from the next bridge, such that a total time period of 1 cycle comes to 60ms. Similarly, at the receiving end another cycloconverter is connecting to use step-up the frequency back to 50Hz.

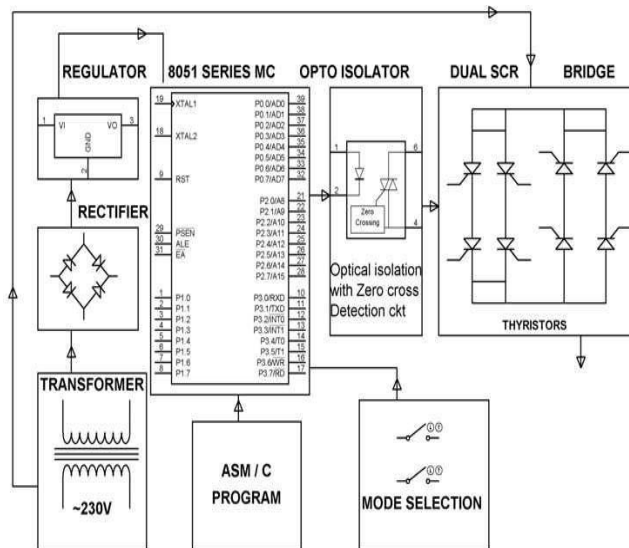

Figure 2. Block Diagram of Cycloconverter

## 2. Frequency Tripler-

At the receiving end, we are use frequency tripler. The purpose of the frequency tripler is to output a sinusoidal signal with a frequency that exactly three times the frequency of the input sinusoid signal. In that tripler circuit we are use bridge rectifier and inverter to step up the frequency. The transmitted one third frequency of transmission line which is connected to the bridge rectifier to conversion of AC/DC. This converted dc line is connected to the DC/AC Inverter to obtain normal frequency (50Hz) ac line. Output of Inverter is connected to load.

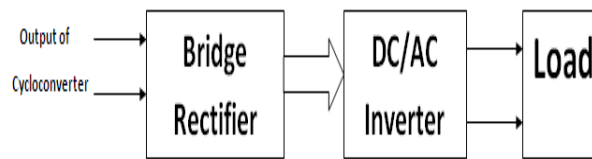
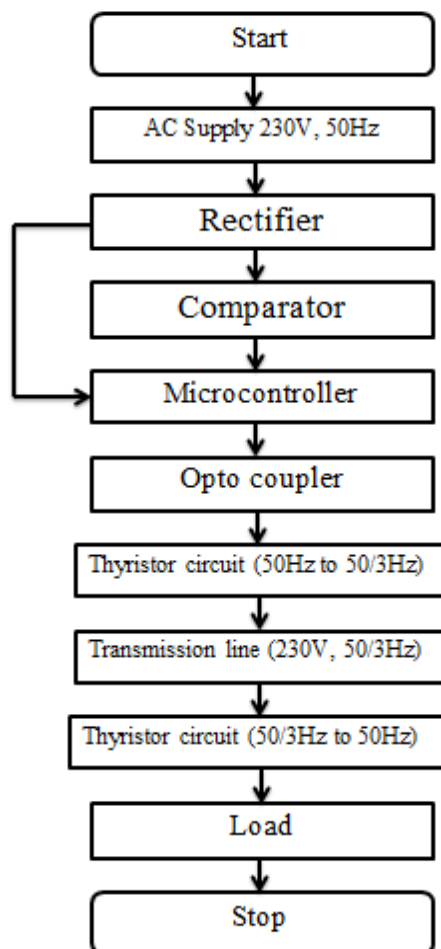

Figure 3. Block Diagram of Frequency Tripler

## 4. FLOW CHART



## 5. RESULT ANALYSIS

### 2) Output Result-

Sr.No	Normal frequency voltage. (V)	Normal Power (W)	Fractional frequency voltage. (V)	Fractional Power (W)
1	300.5	287.43	316	953.55
2	301.5	290.35	318	965.66
3	303	292.24	322	990.11

## 6. CONCLUSION

From the concepts built up about fractional frequency transmission system and the simulation performed, we conclude that:-

1. The electrical length of ac transmission line is reduce and hence the transmission capability is increase to several folds.
2. In FFTS, we use reduced frequency (i.e. one third of the power frequency) for transmission system and therefore losses in the form of skin effect and corona discharge get reduced hence improving stability and performance characteristics.
3. The reduced length of the transmission line leads to minimize the cost of transmission and improvement in the general characteristics.

## REFERENCES

1. Wang Xifan, Cao Chengjun and Zhou Zhichao, "Experiment on fractional frequency transmission system," in *IEEE Transactions on Power Systems*, vol. 21, no. 1, pp. 372-377, Feb. 2006.  
doi: 10.1109/TPWRS.2005.860923
2. Xifan Wang and Xiuli Wang, "Feasibility study of fractional frequency transmission system," in *IEEE Transactions on Power Systems*, vol. 11, no. 2, pp. 962-967, May 1996. doi: 10.1109/59.496181
3. U. S. Satpute, S. H. Jangamshetti and D. R. Joshi, "Feasibility study of Fractional Frequency Transmission System," *2010 Joint International Conference on Power Electronics, Drives and Energy Systems & 2010 Power India*, New Delhi, 2010, p 1-6.  
doi: 10.1109/PEDES.2010.5712507
4. Z. Song, X. Wang, Y. Teng, L. Ning and Y. Meng, "Optimal Control Study for Fractional Frequency Wind Power System," *2012 Asia-Pacific Power and Energy Engineering Conference*, Shanghai, 2012, pp. 1-5.  
doi: 10.1109/APPEEC.2012.6306922
5. T. Yufei, W. Xifan, N. Lianhui, M. Yongqing and S. Zhuoyan, "Unified iterative method to calculate power flow of the interconnected system with Fractional Frequency Transmission System," *2011 4th International Conference on Electric Utility Deregulation and Restructuring and Power Technologies (DRPT)*, Weihai,

Shandong, 2011, pp. 438-443.

doi: 10.1109/DRPT.2011.5993931

6. B. S. Mohan, C. B. Shankaralingappa and R. Prakash, "Fractional frequency transmission system to enhance line loadability in EHVAC & UHVAC long transmission line," *2014 International Conference on Advances in Electronics Computers and Communications*, Bangalore, 2014, pp. 1-6.  
doi: 10.1109/ICAIECC.2014.7002477
7. J. Li and X. P. Zhang, "Small Signal Stability of Fractional Frequency Transmission System With Offshore Wind Farms," in *IEEE Transactions on Sustainable Energy*, vol. 7, no. 4, pp. 1538-1546, Oct. 2016.  
doi: 10.1109/TSTE.2016.2552540
8. S. Sawant, M. Rane and R. Bhosale, "Performance analysis of fractional frequency transmission system using hardware setup," *2015 International Conference on Electrical, Electronics, Signals, Communication and Optimization (EESCO)*, Visakhapatnam, 2015, pp. 1-5.  
doi: 10.1109/EESCO.2015.7253900
9. S. Liu; X. Wang; L. Ning; B. Wang; M. Lu; C. Shao, "Integrating Offshore Wind Power Via Fractional Frequency Transmission System," in *IEEE Transactions on Power Delivery*, vol. PP, no.99, pp.1-1  
doi:10.1109/TPWRD.2015.2