

Squeezing Machine for Autistic Children

Mrs. Saylee Bidwai¹, Ms. Priyanka Yadav², Ms. Pooja Sawant³, Ms. Shital Sawat⁴

Assistant Professor, Department of Electronics And Telecommunication engineering, Annasaheb Dange College of Engineering and Technology, Ashta, Maharashtra, India

Student1, Department of Electronics And Telecommunication engineering, Annasaheb Dange College of Engineering and Technology, Ashta, Maharashtra, India

Student2, Department of Electronics And Telecommunication engineering, Annasaheb Dange College of Engineering and Technology, Ashta, Maharashtra, India

Student3, Department of Electronics And Telecommunication engineering, Annasaheb Dange College of Engineering and Technology, Ashta, Maharashtra, India

Abstract - Deep touch pressure is used as a therapy and according to clinical observations; it is beneficial for children with autistic disorder and sometimes for children with attention-deficit hyperactivity disorder (Special children). This equipment can be assumed under the domain of medical treatment apparatus particularly used for reliving anxiety and bringing calming effects in the autistic children. Regular sessions with the machine have positive effects in handling the traumatic situations better. This squeezing machine model is designed by taking in to consideration the requirements specified by a school of special children.

Key Words: Autism, Deep Pressure Therapy, Music Therapy, calming effects, machine

1. INTRODUCTION

Autism is a neurological developmental disorder typically diagnosed during early childhood. It affects the brain in major areas communication, social skills, sensory systems and behaviour. The Causes arises from genetic and environmental. Autistic people have symptoms such as intolerance to being touched, inability to speak, tantrum, aressivness, and anxiety. Self-injury very severe form of their behaviour that has the highest risk. If they mostly become violent due to some reason then it become difficult to handle them. This violent behaviour can lead to cuts, bruises, dental problems, broken bones, detached retinas.

1.1 Problem Definition

If autistic children become violent due to some reason then it became difficult to handle them. This violent behaviour can lead to cuts, bruises, dental problems, broken bones, detached retinas. If any autistic child become violent generally the traditional methods used to make them calm

down are given them tight hug, roll them tightly in mat, cover up them by heavy blankets, touch therapy by smooth or rough material. But autistic children have problems with oversensitive to touch. They can't tolerate any physical touch.

Most of the designs available in market are inspired by Temple Grandin's 'squeeze machine', which are made up of plywood and capable of applying pressure laterally from both sides of the body of patient. Christopher Morino created a 'Hug Machine' machine for Deep Pressure Stimulation but it was not much popular because it was intimidating in appearance and expensive to manufacture. Tricia Sutton, Ed Minnock and Ken Rolfes refined the Squeeze Machine by providing a squeeze force controller and a compressor. But it made the overall system bulky and noisy (85-105dB). In addition, the user needed training to use this machine.

1.2 Solution and Effects

To overcome this problem we introduce a squeezing machine which deliver deep touch pressure and reduce tantrum and anxiety. In this user don't have to tolerate human touch. This machine will apply specified pressure equally on body for specified amount of time as deep pressure therapy. It is an easy method to control their violence.

Deep Pressure therapy:

Deep pressure touch is one of the therapy used to give the calming effect to the people with autistic disorder and attention-deficit hyper activity disorder (ADHD). Deep pressure simulations such as rolling up in a mat, to hold them tightly, wrapping arms and legs in elastic bandages, sleeping under many blankets even during warm weather are used. But lots of autistic children don't like physical touch, mechanical touch is bit better for them. Having a squeezing machine they don't have to touch people and get sensation.

By squeezing machine we can control the violent behaviour and give them comfort by using deep pressure. It will equally apply pressure on body. It will help them to learn to tolerate touching and to reduce anxiety and nervousness. This applies lateral, inward directed pressure to both aspects of person's entire body, y compressing the user between two panels. In the squeezing machine the user has the complete control over the duration and amount of pressure applied

1.3 Present Theories and Practices

The squeezing machine is invented by Temple Grandin in 1965 at the age of 18. That machine consist of two hinged side boards each 4x3 feet with thick soft padding which form v shape with complex control box and heavy duty tubes using air compressor controlled by the user. A small pilot study published in the American Journal of Occupational Therapy reported that the machine produced a significant reduction in tension, but only a small decrease in anxiety.

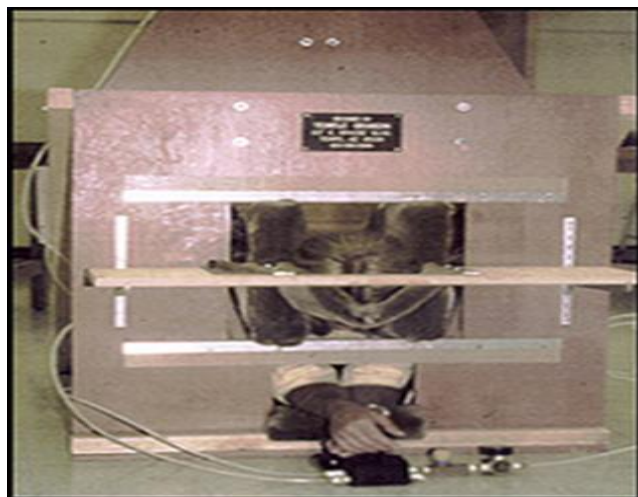

Figure 1.Squeezing Machine Invented By Temple Grandin

For several years in the 1990s,Urban Interventions/artist Wendy Jacob worked with Grandin in developing furniture that squeezes or 'hugs 'users, inspired by Grandins hug machine .In 1991 in research of McClure and Holtz-Yotz found that deep pressure apply by the foam padding on the body which is controlled the behaviour of self-injuries in autistic children.

To overcome the drawback and to develop the squeezing machine which is developed by Temple Grandin in 1965, Wendy Jacob was invented hug machine in the form squeezing chair which apply soothing pressure on the body to reduce anxiety and environmental sensitivity. Which was sponsored by the MIT, List Visual Arts Centre on the campus of MIT, Cambridge.



Figure 2. Squeezing chair by Wendy Jacob

2. PROPOSED WORK

The machine is a bed like structure, on which an autistic child can lie down and pressure can be applied through the fastened wraps by blowing air in it according to the extent of pressure required. The head-rest area is kept uncovered and only a small sidewall is constructed herein small speakers are embedded for listening special music/sounds. An autistic child when suffering from anxiety can be put on this machine.

A comfortable sleeping pad with automatic pressure adjustment and fastening through wraps with inbuilt airbags are provided in the projected machine. A bed like structure gives comfortable posture for children to rest additionally it provides facility to apply pressure on complete body with the help of multiple wraps and fasteners wherein airbags are blown automatically using sensors and microcontroller. Automatic air blowers operating on low voltage avoid manual handling of air pumps.

2.1 Circuit Diagram and Hardware Implementation:

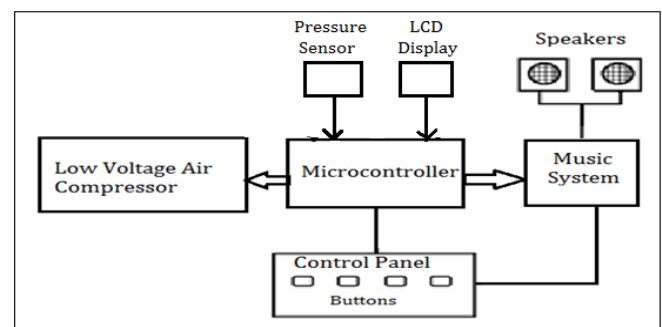

Figure 3: Block Diagram of Electronic Assembly

The electronic assembly consists of a microcontroller, low voltage air compressor, pressure sensor which is used to sense the amount pressure in the airbags. A music system

with two speakers and a control panel to handle all the gadgets. A space will be provided in bed for fitting this assembly where in concealed wiring is done between speakers and controller. Figure-3 shows the conceptual block diagram of the electronic set-up which will be further embedded in different parts of resting bed.

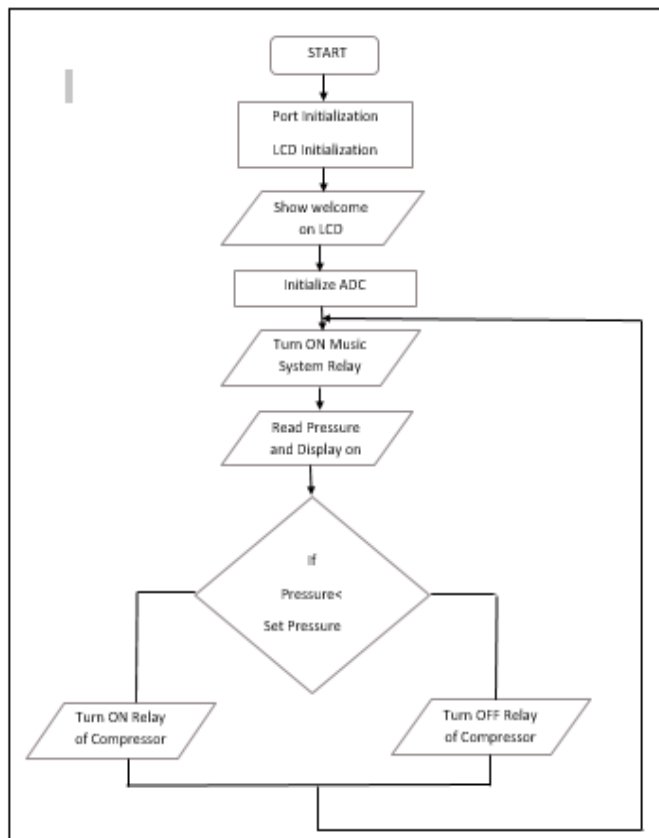

Figure 4: Flowchart



Figure 5: Circuit Diagram

In the System, Pressure Sensor, Air Compressor and Music System are interfaced with Microcontroller. After applying power supply, Air Compressor turn ON through one Relay and Music System switch ON through another Relay. Air compressor blows airbags and pressure sensor sense this pressure and the amount of pressure is instantaneously displayed on LCD. We can vary amount of pressure applied up to 80 PSI. If applied pressure is increased above 80 PSI Air Compressor will automatically turn OFF through Relay. Music System will remains ON until Power Supply is ON and also it can be switched OFF manually as per user requirements.

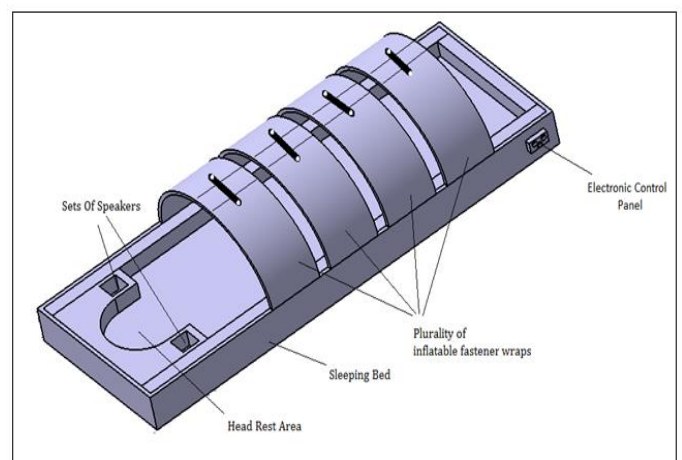

Figure 6: 3D view structure of squeezing machine.

Figure-6 shows a preliminary 3-D view of the machine design. The dimensions of the machine are 6ft X 2.5ft X 1.5ft in length, width and height. The electronic control panel will have buttons for operating music system and automation of air bag blowing and releasing. The garment to be used as cover will be non-inflammable, leakage proof and sturdy. A foam based cushioning will be provided in bed as well as in wraps. Airbags are deployed inside wraps which can be operated automatically from control panel in addition to air pressure adjustment according to need. The head-rest region is surrounded for protection as well as to embed speakers near ears.

A memory chip containing special kind of music will be interfaced with the microcontroller and button will be available for song/ sound selection. Multiple sheets with different textures will be provided to spread on the bed as per the requirement of the child.

3. Results:

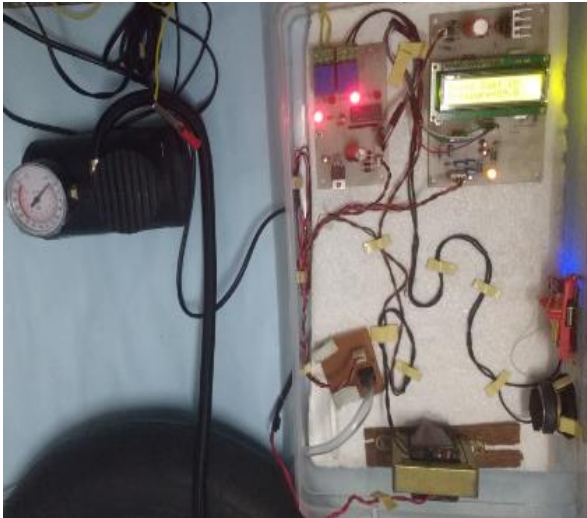

Figure 7: Result of Project

After applying the power, Music system turns ON and Air compressor starts to blow an air in airbags which are presented in a wraps and pressure is applied on body of an autistic children which is displayed on LCD display. After reaching the limit of 80 psi which is sensed by pressure sensor, air compressor automatically turns OFF. And child become calm.

4. Future Scope:

This system will be used in medical field with Artificial Intelligence of database. It consist of an information about children. Name of student, age, required pressure for individual child, how much time pressure will apply etc. information will present in database.

CONCLUSION

This project is applicable to reduce anxiety, tantrum, calm down the children suffer from autism when they become violent. This machine can apply required pressure equally on entire body to give the calming effect. Music therapy is also able to make them mentally stable.

ACKNOWLEDGEMENT

Sincerely, thanks to Mrs Chadda Mam, Principal of Ashadeep special children's school in sangli for giving us permission to interact with the Autistic children, information about the behavioral characteristics of those children.

REFERENCES

- [1] Dr. K V K K Prasad, Embedded/Real-Time Systems: Concepts, Design & Programming, Dreamtech Press
- [2] Global Burden of Disease Study 2013 Collaborators (2015). "Global, regional, and national incidence,

prevalence, and years lived with disability for 301 acute and chronic disease and injuries in 188 countries, 1990-2013: a systematic analysis for the Global Burden of Disease Study 2013". Lancet. 386: 743-800.

- [3] Grandin Temple (1996).Thinking in pictures: Other reports from My Life with Autism.
- [4] Internet.
- [5] JOURNAL OF CHILD AND ADOLESCENT PSYCHOPHARMACOLOGY: Mary Ann Liebert, Inc., Publishers, Volume 2, Number 1, 1992.
- [6] Muhammad Ali Mazzidi. "The 8051 Microcontroller and Embedded Systems: Using Assembly and c"
- [7] Nikolovska, Lira Ackermann, Edith; Cherubini, Mauro (2008). "Exploratory Design, Augmented Furniture?" In Pierre Dillenbourg; Jeffrey Huang; Mauro Cherubini. Interactive Artifacts and Furniture Supporting Collaborative Work and Learning.
- [8] Raj Kamal" Embedded System", McGraw Hill.
- [9] The Squeeze chair Project Wendy Jacob with Temple Gardin.
- [10] The Times of India. Apr 2, 2013

BIOGRAPHIES

1. Mrs Bidwai S.S.: Assistant Professor, Electronic and Telecommunication Department of Annasaheb Dange College of Engineering and Technology, Ashta, Maharashtra, India. M.E. (Electronics), Ph.D. (Registered).
2. Ms. Yadav Priyanka R.: Appeared B.E at Electronic and Telecommunication Department of Annasaheb Dange College of Engineering and Technology ,Ashta, Maharashtra, India.
3. Ms. Sawant Pooja M.: Appeared B.E at Electronic and Telecommunication Department of Annasaheb Dange College of Engineering and Technology, Ashta, Maharashtra, India.
4. Ms. Sawat Shital R.: Appeared B.E at Electronic and Telecommunication Department of Annasaheb Dange College of Engineering and Technology, Ashta, Maharashtra, India.