

“GSM BASED ENERGY METER MONITORING AND LOAD CONTROL”

Mr. Darshit S. Patel, Vadodara Institute of Engineering, Vadodara, India.

Mr. H.B. Patel, Vadodara Institute of Engineering, Vadodara, India.

Abstract: The main aim of our Article is to make the job of electricity board easy and less time consuming, in respect to the monitoring and load control of the consumers' energy meter. As we all know that the ELECTRICITY BOARD use to send the employees to the consumer side for taking the load readings or the consumption readings at the end month or two months, usually this whole process is used to be contracted by the electricity board with the sub-authorities. Hence the employees from the sub-authority will fetch the reading from the consumer houses and use to deliver this data to the board, after which the respective BILLS are issued. But unfortunately this whole process is full of errors and defects. Yet behalf of all this tedious work, we could make it very easy and simple with the application of the project GSM BASED ENERGY METER MONITORING AND LOAD CONTROL. In which just by sending the required message to the specified number we can get the desired feedback within the fraction of seconds. This communication is based on GSM communication system for fast feedback.

Keywords: GSM, Energy Meter, Prepaid Meter, Load Control

I. Introduction

Our Article mainly deals in the channel between the electricity provider and the consumer. Usually the electricity board use to send the employees to the consumer side for taking the meter reading at the end of particular instant. Normally these employees are made on short-term contract basis or are provided from sub authorities on the contract basis only. This job becomes difficult and time consuming because sometimes there may arises the clashes between one or more authorities due to which the misplace of data takes place. These data, which is acquired by the employees, are conveyed to the electricity board and then the final bills are issued and distributed among the consumers. Yet this whole process works effectively but it needs some of the modification as it is so time consuming, costlier, as well as the tedious job. Moreover there are many difficulties for the employees to reach at some of the places depending on the various atmospheric as well as the geographical conditions.

II. Block diagram:

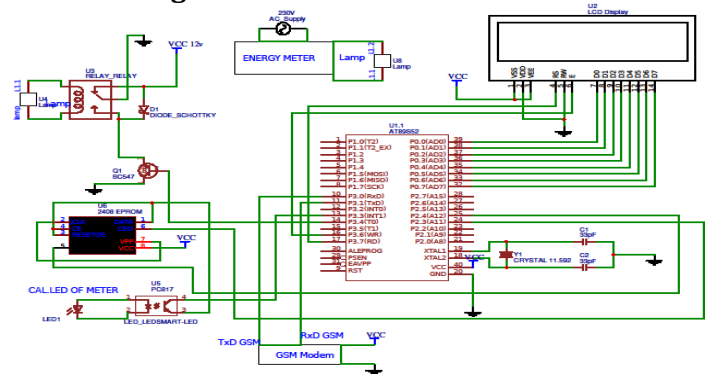

Fig.1: Block diagram

The basic implementation theory includes the step by step processes that should mentioned in the chronological order; the major working parts that should be covered in order for the completion of the project are as mentioned below;

- ❖ Making of the basic microcontroller kit.
- ❖ Making of the power circuit for the microcontroller kit.
- ❖ Taking the pulses out from the energy meter.
- ❖ Interfacing of the energy meter with microcontroller via opto-coupler (PC817).
- ❖ Study of the basic GSM Module.
- ❖ Making of the MAX232 circuit for GSM Modem. Also here in sim300 max232 circuit is provided inbuilt.
- ❖ Interfacing of GSM Modem with microcontroller via MAX232 circuit.
- ❖ Interfacing of the load.
- ❖ Coding/Programming

III. How to take the pulses from the energy meter

Since we have used the **STATIC ENERGY METER** for the project purpose, in that we have to take the pulses out for the calculation of the consumption by the loads. We have coupled the static energy meter with the microcontroller using the **OPT coupler**, the Cal led of the meter is replaced by the optocoupler's led and hence the blinking of the CAL. Led is projected on the transistor of opt coupler.

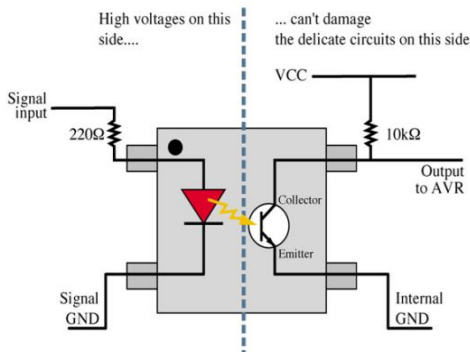

Fig.2: Opt coupler PC817



Fig. 3: Meter 1

Here the dismantled view of the STATIC ENERGY METER is as shown in fig. no 3, since the CAL LED is able to be observed from the right side of the figure. After this, we have replaced the CAL LED by cutting the anode of the LED and connecting it to the opto-coupler LED of the transfer of the pulses, which is as shown in the figure;



Fig.4: Meter 2

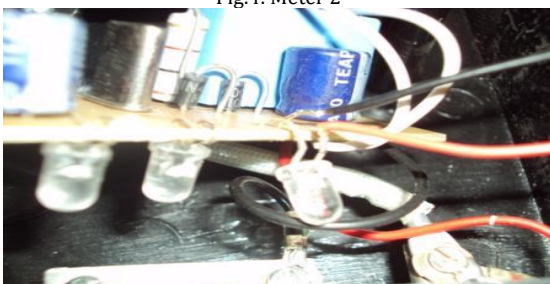

Fig. 5 Meter 3

The below figure shows the soldering of the anode terminal with the opto-coupler. Yet finally the completion of the soldered LED is shown in the below figure.

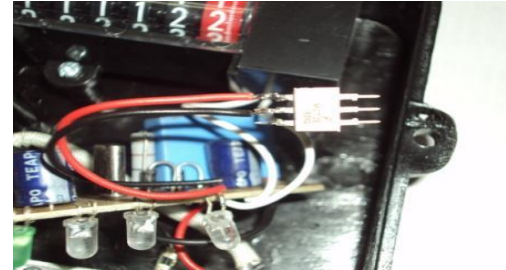

Fig. 6: Meter 4

V. Making of MAX232 circuit

Max232 is used to interface the GSM MODULE and the microcontroller, since the operating voltage of the microcontroller is within +- 5v, whereas the operating voltage of the GSM MODULE varies from +-25v. In order to match the voltage levels with the full efficiency MAX232 is used as a intermediate component.

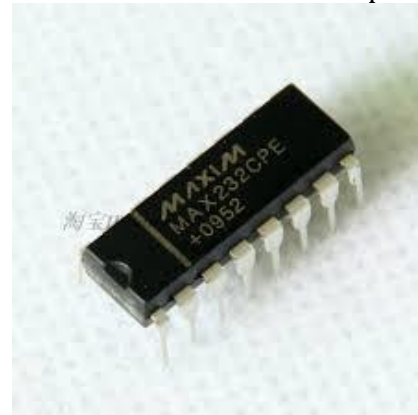

Fig. 7: MAX232

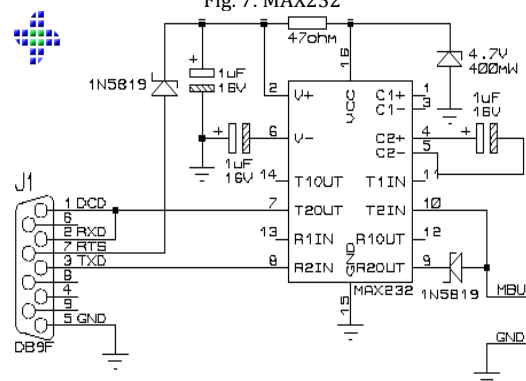

Fig.8: Circuit diagram of MAX232

Interfacing of LCD Display

Here the circuit diagram of the LCD display is as shown below, where as in our project we have used the port 0 for interfacing of the LCD display, also we have given the potentiometer for varying the required intensity. Moreover we have used the 16*2 LCD as the length of the lines which to be displayed are minimum and are

satisfied by the required model, one can also use bigger size of the LCD display for the required use.

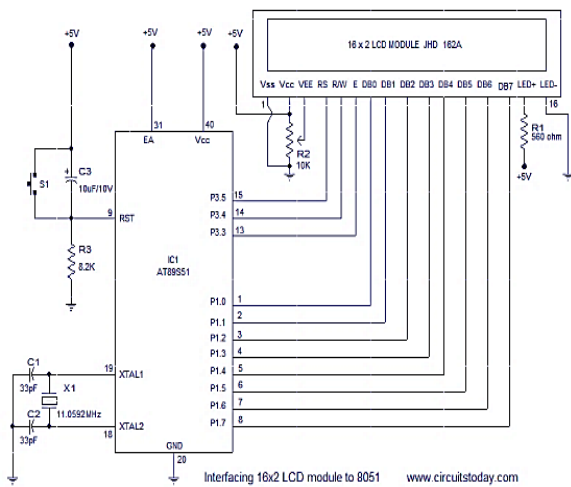

Fig. 9: Interfacing of LCD

VI. Advantages & Disadvantages

Advantages:

- ❖ Positive feedback
- ❖ Less time consuming
- ❖ Automation is achieved
- ❖ A convenient and efficient method to avoid the problem of electricity department sending employees for taking meter reading every month.
- ❖ No human errors in taking the meter readings.
- ❖ Free from outsider interference, entering the private places.
- ❖ Economical and simple to use.

Disadvantages:

- ❖ Network problem.
- ❖ Reduces the number of employees.

VII. Conclusion

Thus with the use of this Article we can make the system easy and less time consuming. Also with this we have reduced the disadvantages of the current system. One can establish user friendly and direct interfacing between the consumer and the distributor without any external interference. Also with this, the accuracy of the system increases as the gross errors, observational errors, etc. decreases. Thus with this we can conclude, that a time efficient, reliable, and accurate system analysis can be obtained which is indeed economical and user friendly.

VII. Future Scope

As there are plenty of ideas and innovation that one could implement, there are also many innovative ideas that can be processed further or extended further in our project. Since here we are concentrating on the provider side, i.e. at the ELECTRICITY BOARD. One can also include the features related to the customer side, ie making the fixed usage manual, thus by making the recharge of a particular amount, customer will be allowed to use the supply depending upon the plan selected as similar to the PREPAID sim card systems, which would enhance the experience of the economic consumer with modern digital utility meter. One can also include the feature of INSTANT BILL, at any instant of the time. By this feature consumer can know his/her bill at any interval of the month, so that an economical consumer can vary his/her consumption. Also a timer control can be provided, which would automatic cut down the system supply, if the payment of bill is not done in the specified time limit.

References:

- [1] Abdollahi, A. Dehghani, M. Zamanzadeh,|| SMS-based Reconfigurable Automatic Meter Reading System|| in Control Applications, 2007.
- [2] Amin S. Mehmood, T. Choudhry, M.A. Hanif, A –Reviewing the Technical Issues for the Effective Construction of Automatic MeterReading System|| in International Conference on Microelectronics, 2005 IEEE.
- [3] Bharath, P.; Ananth, N.; Vijetha, S.; Prakash, K.V.J.; –Wireless Automated Digital Energy Meter|| in Sustainable EnergyTechnologies, ICSET 2008.
- [4] Chih-Hung Wu; Shun-Chien Chang; Yu-Wei Huang; –Design of a wireless ARM-based automatic meter reading and control system|| in Power Engineering Society General Meeting, 2004. IEEE.
- [5] Detailed Project Report - Intelligent Transport System & Ethanol Diesel - KSRTC, Mysore. p. 62.
- [6] Baghyasree T, Janakiraman K, Parkavi D. Efficient remote video monitoring for industrial environment based on LPC2148 and GSM. Indian Journal of Science and Technology. 2014 7(9): 1333– 41.
- [7] Silviya EM, Vinodhini KM, Salai Thillai Thilagam J.GSM Based automatic energy meter system with instant billing. International Journal of Advanced Research in Electrical, Electronics and Instrumentation Engineering. 2014; (3):44–9.

BIOGRAPHIES

Mr. H B PATEL received the DEE degree from TEB, BE degree from VNSGU, ME degree from GTU in Electrical Engineering in 2004, 2009, and 2012 respectively. He is pursuing doctoral degree in Madhav University since 2016. He is an Assisatnt Professor with the Department of Electrical Engineering in Vadodara Institute of

Engineering and Research, Gujarat Technological University, Ahmedabad. His current research interests in Renewable Energy Sources, Power quality, Control Strategy, Power management.



Mr. Darshit Patel received the BE degree from CITC, Changa, ME degree from University of Bridgeport (USA) in Electrical Engineering in 2007 and 2010 respectively. He is an Assisatnt Professor with the Department of Electrical Engineering in Vadodara Institute of Engineering, Gujarat Technological University, Ahmedabad.

His current research interests in Design of Electrical Machine and Power System.