

Efficient Energy Harvesting and Transmission using Wireless Sensor Networks

A.Rehana Fathima¹,S.Sivaranjani²,J.Prem Sagar³,K.Suriya Kumar⁴

¹²³⁴UG Students, Department Of Electronics and Instrumetation,Valliammai Engineering College,Tamil Nadu,India.

Abstract- "Smart energy generation and distribution system is implemented here".Here the energy generator is "Peltier". The Peltier sensor converts the thermal energy into electrical energy. The voltage is generated from the heat produced by the engine of the vehicle and the generated voltage is stored in the external battery. The stored energy is transferred to the local substation. The cost of energy complemented by the individual is added to the user account. The user can use the money for filling up the fuel in petrol bunks. Utilisation of waste heat energy is done here. Wasted heat energy from vehicles is used effectively to produce electricity. Reverse peltier effect is used for the production of electricity from wasted heat energy. Wireless power transmission of voltage is done here. Power contributed by individual is given to them as fuel.

1. INTRODUCTION

Wireless Sensor Networks (WSN) have played an important role in many monitoring and surveillance applications including environmental sensing, target tracking, structural health monitoring. As conventional sensors are powered by batteries, the limited battery capacity obstructs the large-scale deployment of WSN. Although there are many energy-aware approaches developed in the past decade to reduce sensor energy consumptions or balance energy expenditures among sensors, the lifetime of WSNs remains a main performance bottleneck in their real deployments, since wireless data transmission consumes substantial sensor energy. To mitigate the limited energy problem in sensor networks, researchers proposed many different efficient approaches. One method is to enable sensors to harvest ambient energy from their surroundings such as solar energy, vibration energy, and wind energy. However, the temporally and spatially varying nature of renewable energy resources makes the prediction of sensor energy harvesting rates very difficult. For instance, it is shown that the energy generating rates in sunny, cloudy and shadowy days can vary up to three orders of magnitude in a solar harvesting system. Moreover, the harvesting energy sources are intermittent and not always available. Such unpredictability and intermittency pose enormous challenges in the efficient usage of harvested energy for various monitoring or surveillance tasks.

2. ABBREVIATION:

WSN -Wireless Sensor Network

WPT -Wireless Power Transfer

PIC -Programmable Interface Controller

3.GENERAL BLOCK DIAGRAM

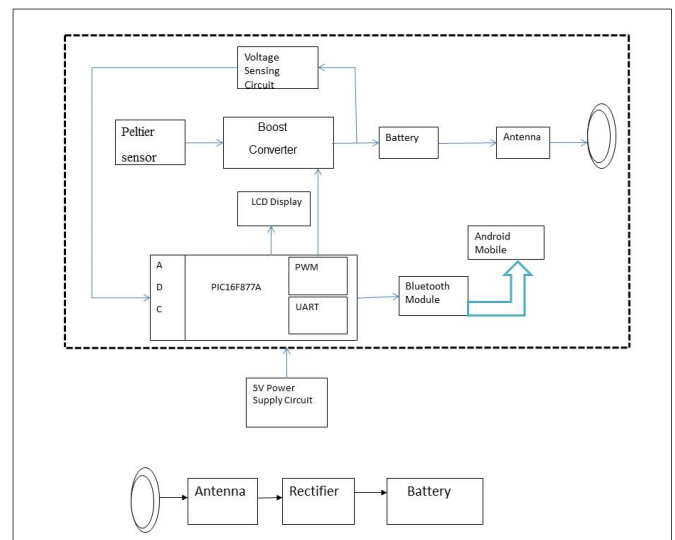

Fig-3:General block diagram

The circuit consists of three main sections

- 1.Transmitter Section
- 2.Receiver Section
- 3.IOT Section

3.1 TRANSMITTER SECTION

"Peltier sensor" placed near the engine area is connected to a "Boost Converter". The boost converter is used to amplify the voltage generated by the peltier. The generated voltage is stored in the battery placed inside the car near the engine. The DC voltage generated is converted into an RF signal and sent to the transmitter antenna.

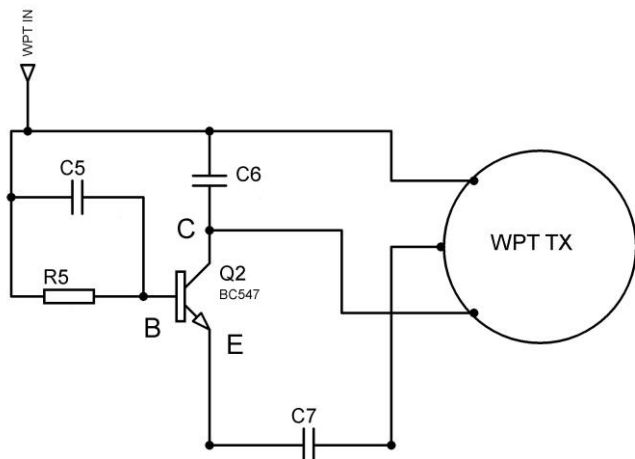

Fig -3.1: Transmission circuit

The transmission circuit consists of two non-polarity capacitors, a transistor and a protection resistance. When output from the boost converter reaches the transmission circuit the capacitor C5 charges and hence the base of the transistor is biased. A current flows via the emitter through the C7 capacitor. Here positive half of the voltage is generated. Now the charging is reversed and the capacitor C6 is charged which generates the negative half of the voltage. This operation converts the dc voltage to the RF signal which is transmitted via an antenna.

3.2 RECEIVER SECTION

The transmitter antenna sends the RF signal to the externally placed receiver antenna by the principal of mutual induction. A rectifier is used to produce the dc voltage since the received signal will have some oscillations. The voltage received is stored in an external battery and it is sent to the EB.

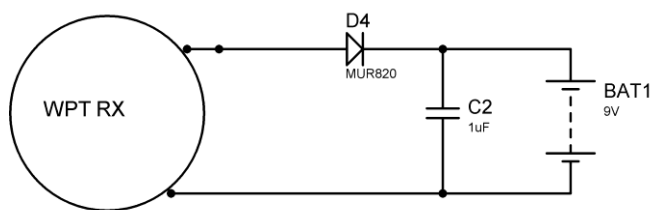

Fig -3.2: Receiver circuit

3.3 IOT SECTION

Internet of Things is like a brain. It can both store the real world data and can also be used to monitor the real world parameters, make meaningful interpretation and even make decision based on the sensed data. It is responsible for data

processing, manipulation and decision making.

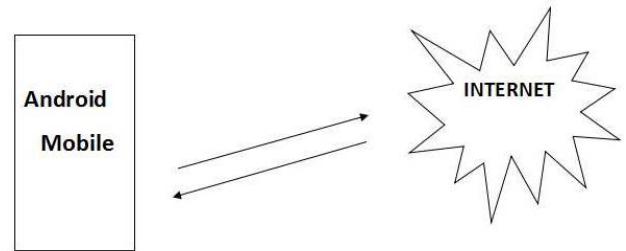

Fig -3.3: Data transfer through IOT

Here the generated voltage range is updated to the server via “Bluetooth module” and the server maintains the details of the data and convert the energy value proportionately to the money for cost free fuel fill up.

4. PELTIER

Peltier sensor is based on the peltier effect. According to the peltier effect the two sides of the peltier sensor can be made hot or cold by changing the direction of the input current. Here no cold is created but the heat energy is pumped from one side to the other. The reverse principle is used for the generation of voltage.

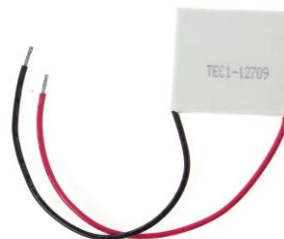

Fig -4: Peltier sensor

The peltier sensor is made up of many p-type and n-type semiconductors which does the pumping of heat from one side to the another side of the peltier sensor. One side of the peltier sensor acts as the cold junction which absorbs the heat and the other side acts as the hot junction which dissipates the heat.

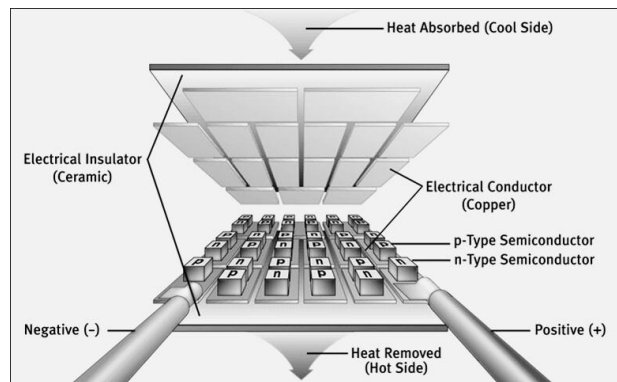

Fig-4.1:Peltier operation

5. BOOST CONVERTER

Boost Converter is used to boost the output voltage than the voltage given by the peltier as its input. By high switching of the MOSFET switch we can charge the inductor and discharge it continuously. A PWM signal is given by the microcontroller in order to switch the MOSFET. The desired time period for the PWM signal and the duty cycle is given by the microcontroller.

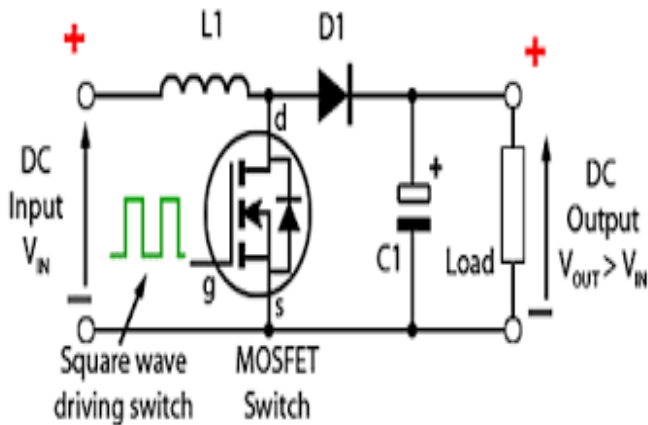

Fig-5: Boost converter

A high period high frequency pulse wave is applied to the gate of the transistor switch such that the transistor conducts and the inductor charges. When the transistor is off the capacitor charges and the output is obtained simultaneously. Again when the transistor is on, the capacitor discharges and supplies the output. This occurs repeatedly and the output is boosted.

Table-1: PWM frequencies

PWM Frequency	1.29 KHz	4.88 KHz	19.5 3KHz	78.1 2KHz	156.3 KHz	208.3 KHz
Timer Pre scaler (1, 4, 16)	16	4	1	1	1	1
PR2 Value	0xFF h	0xFF h	0xFF h	0x3F h	0x1F h	0x17 h
Maximum Resolution (bits)	10	10	10	8	7	5.5

6. VOLTAGE SENSING CIRCUIT

The voltage sensing circuit is nothing but a voltage dividing network which consists of varying resistances connected serially. The voltage generated by the boost converter is given to this circuit in order to split the voltage given to the

pic microcontroller. This is done in order to prevent the microcontroller from damage by high voltage.

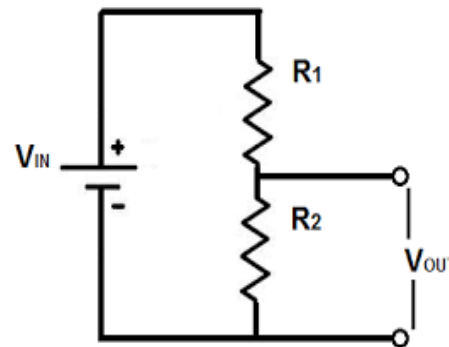

Fig -6: Voltage sensing circuit

7.USART

Universal Asynchronous Receiver Transmitter is used for the Bluetooth communication in the transfer of the digital data. The voltage generated is given via the voltage sensing circuit to the ADC channel of the pic microcontroller. The ADC channel converts the analog signal into the digital data and it is send to the Bluetooth module through USART communication.

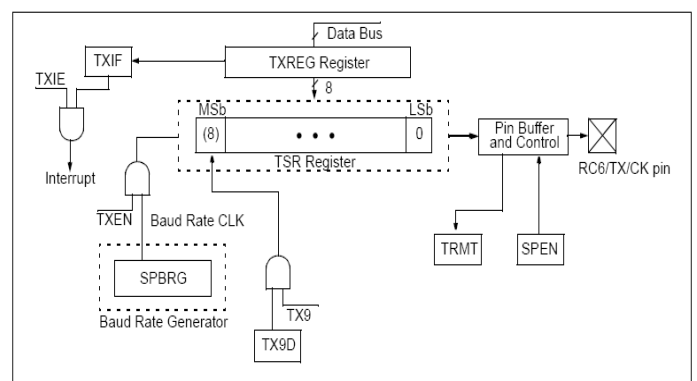

Fig-7.1:USART Transmitter Section

The bluetooth module placed near the engine is paired with an android mobile by turning on the bluetooth communication. The voltage generated is transferred digitally to the mobile continuously. The received information is thrown to the EB via the android application. The resulting cost for the voltage generated is received in the mobile which is used for fuel fill up.

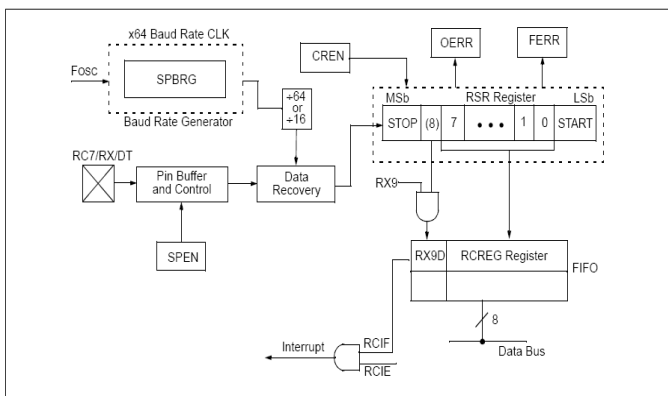

Fig-7.2:USART Receiver section

8. PIC MICROCONTROLLER (1688F7A)

Pic microcontroller has many special characteristics compared with other microcontrollers. It has 256 bytes of EEPROM data, it is self-programming, it has flash memory so that it can be programmed many number of times. It has two 8-bit timers and one 16-bit timer, a 10-bit ADC channel. It has inbuilt USART and PWM generator.

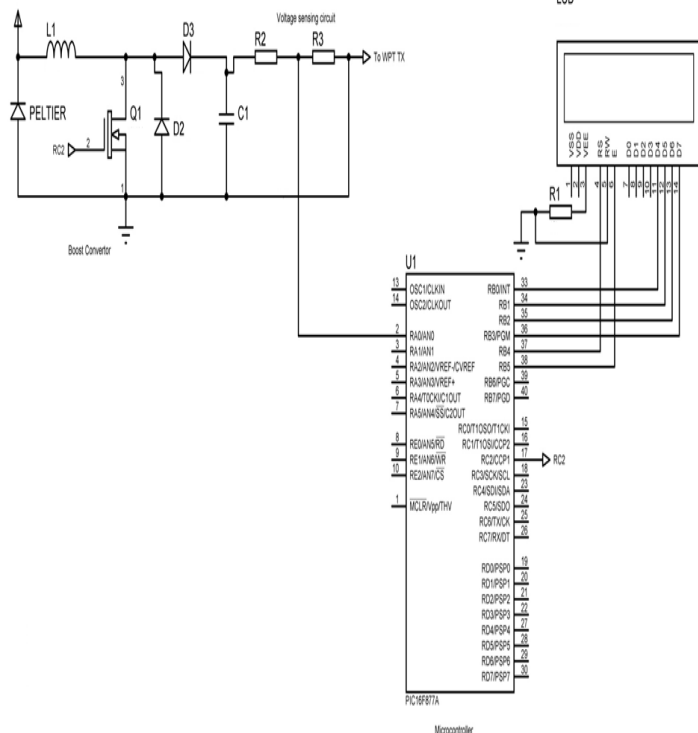

Fig-8:Pic Microcontroller interfacing

The ADC channel of the microcontroller converts the voltage generated by the peltier into the digital voltage. This digital information is given to the Bluetooth module via USART by the microcontroller. A PWM signal generated by the microcontroller is used to switch the mosfet of the boost

converter. Microcontroller controls the time period and duty cycle of the PWM signal.

9.LCD

LCD (Liquid Crystal Display) screen is an electronic display module and find a wide range of applications. A 16x2 LCD display is very basic module and is very commonly used in various devices and circuits. LCDs are economical, easily programmable and have no limitation of displaying special & custom characters and animations. Here the input voltage i.e. the output voltage of the sensor, the boosted voltage by the boost converter and the current is displayed.

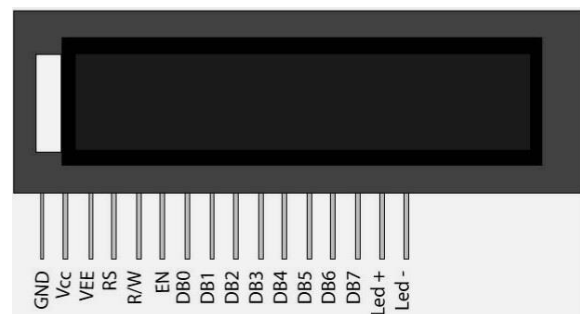

Fig-9:LCD

8.CONCLUSIONS

In this paper we introduce the concept of wireless transmission of voltage generated by the peltier sensor by mutual induction. Here the heat energy is not produced purposely but the utilization of that wasted energy is done effectively. We finally evaluated the performance of the proposed algorithms through simulations and experimental results which showed that the proposed concept is very promising.

REFERENCES

- I. F. Akyildiz, W. Su, Y. Sankara subramaniam, and E. Cayirci, "Wireless sensor networks: A survey," *Comput. Netw.*, vol. 38, pp. 393–422, Mar. 2002.
- G. Anastasi, M. Conti, M. D. Francesco, and A. Passarella, "Energy conservation in wireless sensor networks: A survey," *Ad Hoc Netw.*, vol. 7, no. 3, pp. 537–568, May 2009.
- J. Chang and L. Tassiulas, "Maximum lifetime routing in wireless sensor networks," *IEEE/ACM Trans. Netw.*, vol. 12, no. 4, pp. 609–619, Aug. 2004.
- D. R. Cox, "Prediction by exponentially weighted moving average and related methods," *J. R. Stat. Soc.*, vol. 23, no. 2, pp. 414–422, 1961.
- Green Orbs: A Long-Term Kilo-Scale Wireless Sensor Network System in the Forest <http://www.greenorbs.org>.