

PASSIVE SAFETY SYSTEMS FOR BIKE VIA HELMET

R. REWANTH^[1], M. SAKTHI GANESH^[2]

¹ Student, Department of Automobile Engineering, Sriram Engineering College, Tamil Nadu, India

² Student, Department of Automobile Engineering, Sriram Engineering College, Tamil Nadu, India

Abstract - Multiple active safety systems such as ABS and Stability program are used presently in most two-wheelers. However, there isn't any passive safety system which makes the rider vulnerable during accidents. Even though the helmet which riders use is a passive safety system, most people ignore them as it is optional. The following project design will make the helmet compulsory for a bike while riding past a posted speed limit of 30kmph and prevent the rider from "drink and drive". The helmet has a physical sensor and an alcohol sensor which is connected to the Arduino board using a RF Module as wireless link which communicates between the board and the sensor. If the rider rides past the pre-designated speed limit of 30kmph without wearing the helmet or if the rider is drunk, ignition would turn off, preventing the rider to travel at high speed without protection and will prevent serious injuries in case of any accident. The design consists of a "Helmet Holder" which the component in which the helmet can be placed while the vehicle is at rest. It has an inbuilt lock in the holder, this way the helmet will always be in contact with the bike, so that the rider does not ignore or forget the helmet.

Key Words: Riders safety, Passive safety system, Speed Criteria.

1.INTRODUCTION

In recent times, helmets have been made compulsory in India. Traffic accidents in India have increased year by year. As per section 129 of motor vehicle act 1988, makes it a requirement for every single rider riding a two-wheeling to wear protective headgear following standards of the BIS (Bureau of Indian Standards). In India riding without a helmet is an offence of the motor vehicle act of 1988, which states that the rider will be punished. The main purpose of helmet is to protect us during from head injuries during an accident. In addition, most of them tend to forget their helmet in their homes, therefore in order to make sure that the helmet is always in contact with the bike, there will be a helmet holder placed on the petrol tank will help the rider to place and lock the helmet when the vehicle is parked, so that the helmet is present in the bike at all times.

These are the main issues which urged us to develop this project. The first step is to measure the vehicle speed which is done by connecting a digital

speedometer to the wheel. This will feed data to the Arduino board. The second step is to check whether the helmet is worn or not, hence we use a FSR sensor which will send digital data to the board. An MQ3 alcohol sensor is used to detect whether the rider is drunk or not and it sends the information to the Arduino board.

The above components are controlled by a microcontroller, Arduino Uno and a signal transmission unit using RF concept.

2. TECHNICAL STUDIES

2.1 Force Sensing Resistor (FSR)

Force Sensing Resistor is placed at inside the helmet where the actual human touch is sensed. It determines by helmet unit that whether helmet is worn or not. If this condition will satisfy or not satisfied, then it sends the signal to bike unit. Force Sensing Resistors, or FSRs, are strong polymer thick film (PTF) devices that resistance is inversely proportional to force applied to the face of the sensor. This sensor is used as human touch control in various applications. Such as medical systems, automotive electronics and in robotics and industrial applications. Force sensing resistor is two-wire sensor with a resistance that changes on applied force. The resistor RM is selected to maximize the required force sensitivity range and to limit current. Here we use 10 kΩ of measuring resistor

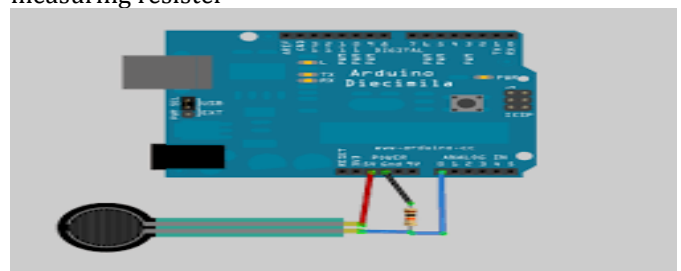

FIG -1: FORCE RESISTING SENSOR

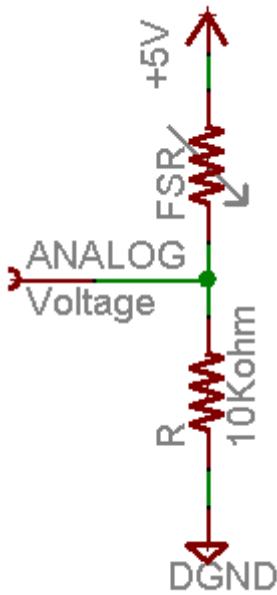

FIG -2: FSR Logic Diagram

2.2 Arduino Uno microcontroller:

Arduino Uno is a microcontroller board based on the ATmega328P ([datasheet](#)). It has 14 digital input/output pins (of which 6 can be used as PWM outputs), 6 analog inputs, a 16 MHz quartz crystal, a USB connection, a power jack, an ICSP header and a reset button. It contains everything needed to support the microcontroller connect it to a computer with a USB cable or power it with a AC-to-DC adapter or battery to power the board.



FIG -3: ARDUINO

2.3 RF COMMUNICATION CIRCUIT

Helmet unit and Bike unit are connected by wireless link of RF. RF communication circuit contains encoder and decoder circuit. Encoder is on helmet side which is using to convert parallel data into serial data. The encoder is capable of encoding message which contains of 12N data bits and N address bits. Each address/data can stay set to with two

logical states. The oscillator frequency is selected by R_{osc} . We choose oscillator frequency is 3 kHz, with R_{osc} of 1M ohms. Minimum transmission of data is 4 words. Decoder is on bike side, it used to decode serial data. It converts this serial data in to parallel. The decoders are capable to receive data that are spread by an encoder and understand it. The first bit's period use as addresses and last 12N bits as our desired data, where N is stands for address number. In this decoder circuit oscillator frequency is 50 times greater than f_{OSCE} (encoder oscillator frequency). f_{OSCD} is 150 kHz, which is select by value of R_{osc} . R_{osc} is 1k ohms.

2.4 MQ3 ALCOHOL SENSOR

MQ-3 gas sensor is right for identifying the alcohol content from breath. It can be positioned just front of the face. The sensor is responds to various gases. It determines by helmet unit that weather the rider is drunk or not. MQ-3 sensor has potentiometer to adjusting different concentration of gasses. We calibrate the detector for 0.4mg/L of Alcohol concentration in air and use value of resistance is 200 K Ω . MQ-3 has supports for both analog and digital. MQ-3 has a 4 pin namely GND, VCC, A_{out} , D_{out} . Here we use digital output of this sensor which is gives output in terms of high or low. It decided by our helmet unit weather rider is drunk.



FIG -4: ALCOHOL SENSOR

2.5 HELMET HOLDER

The helmet holder is a simply a component made of fibre reinforced plastic which has a shape of the helmet's base structure, consisting of a grip and a magnetic lock to attach the helmet to the holder. The helmet and the helmet holder are to be designed specifically for each other in order for them to engage and disengage properly. This simple device would serve as a lock for the helmet in a most convenient manner when placed over the fuel tank. It is attached to the bike using a permanent joint such as rivets or welding to the tank.

2.6 MAGNETIC REED SWITCHES:

The Reed devices are electronic or electromechanical components that work using the technology of the reed contacts, realized for the first time by the Bell. The Reed contact switch is a lamina (normally open) which closes in

the presence of a magnetic field. The reed contacts have found use in the production of various types of sensors. There are two modes of use of these contacts: simple pure contacts, for the detection of a magnetic field; complex equipment, in which the reed contact is used as the transduction element.

3. CONSTRUCTION

3.1 HELMET UNIT

The project consists of two components helmet and the bike. In helmet unit, the force sensing resistor is placed on inside upper part of the helmet where the head of the rider touches the sensor surface. The alcohol sensor is placed near the chin surface of the helmet. A rechargeable battery is mounted on upper side of the helmet.

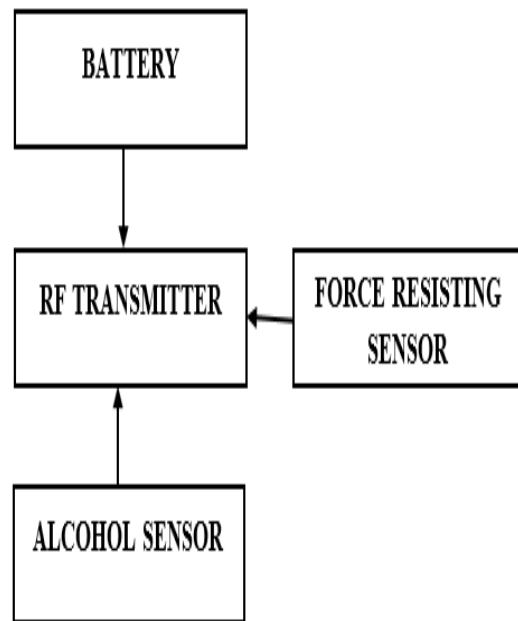

Fig -5: CONTROL UNIT

5. FLOWCHART AND REPRESENTATION

The first step is to initialise all ports, then to initiate communication between the control unit and helmet unit using RF communication. Then the helmet checks for alcohol sensor signal, if the sensor gives positive for alcohol then the vehicle will turn the relay state off. If the alcohol sensor is in off state then the vehicle speed sensor will check for the speed and if the speed is above 30kmph it will check for helmet, if the helmet is worn then the relay will be on. If the helmet sensor is off then the relay state will turn off signalling the ignition to turn off, then the loop continues until the vehicle is on. By this we can eliminate the risk of the rider removing the helmet when he is past 30kmph.

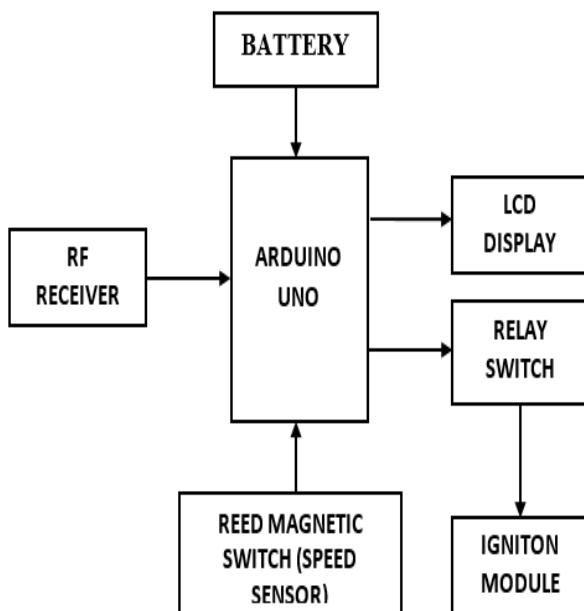

Fig -4: HELMET UNIT

3.2 CONTROL UNIT

The control unit is mounted on the bike. The microcontroller along with relay is connected to the ignition wiring. There is a 16x2 LCD display indicating the vehicle speed along with the relay position. The helmet holder is placed on top of the tank which is used for placing the helmet safely while parking with a lock feature that ensures that the helmet is always present on the bike. By this way, it would be convenient to keep the helmet safe and on the bike at all the times.

5. ADVANTAGES, APPLICATION AND FUTURE SCOPE

5.1 ADVANTAGES

- Prevention of series injuries during high speed accident.
- Option to avoid the helmets while riding less than 30kmph
- Customizable on running solar power also.
- Helmet holder will serve the purpose of a convenient helmet lock
- If helmet is stolen or lost, we can easily customize new helmet with required RF signal.

5.2 APPLICATION

- Prevention of series injuries during high speed accident.
- Option to avoid the helmets while riding less than 30kmph
- Customizable on running solar power also.
- Helmet holder will serve the purpose of a convenient helmet lock
- If helmet is stolen or lost, we can easily customize new helmet with required RF signal.

5.3 FUTURE SCOPE

- Prevention of series injuries during high speed accident.
- Option to avoid the helmets while riding less than 30kmph
- Customizable on running solar power also.
- Helmet holder will serve the purpose of a convenient helmet lock
- If helmet is stolen or lost, we can easily customize new helmet with required RF signal.

6. RESULT

6.1 When the vehicle starts, the bike will check for alcohol sensor and then display "VEHICLE SPEED" and "IGNITION ON"



6.2 When the vehicle is running below 30kmph with or without helmet it displays "VEHICLE SPEED" "IGNITION ON".

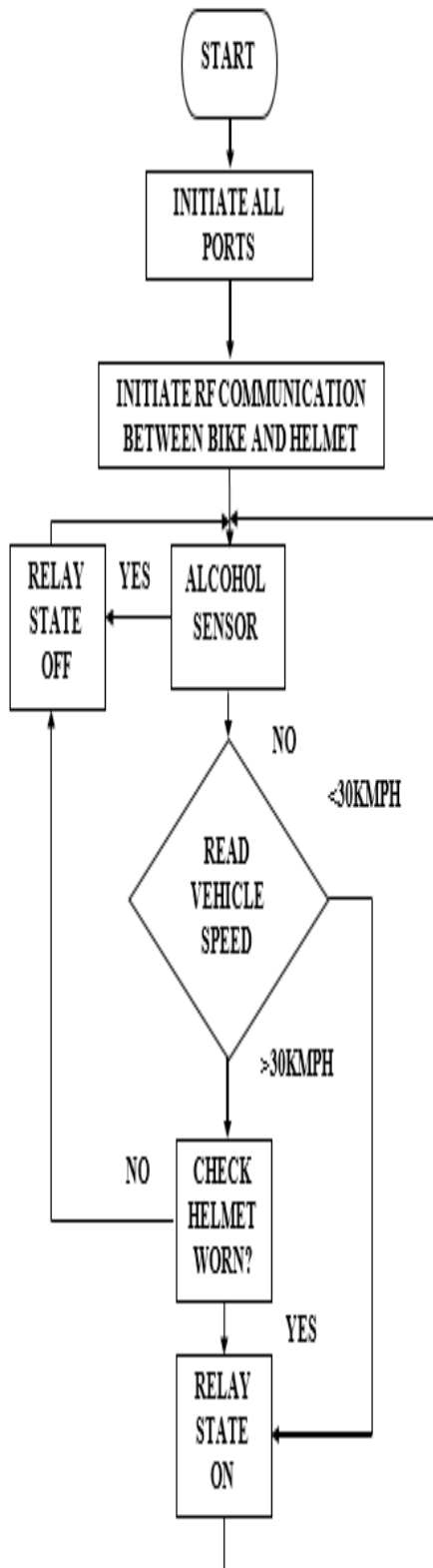



6.3 when the vehicle is running above 30kmph without helmet it displays "VEHICLE SPEED" "IGNITION OFF".



6.4 When the vehicle is running above 30kmph with helmet it displays "VEHICLE SPEED" and "IGNITION ON".



6.5 When the helmet is worn and the rider is drunk.



7. CONCLUSION

The outcome of the project has showed that the ignition will automatically turn off if the helmet is not worn when exceeding the speed limit of 30kmph or when the rider is drunk, this will make sure that the rider is safe.

ACKNOWLEDGEMENT

we would like to thank to our Department of Automobile Engineering, Sriram Engineering college for their guidance and support. Also, we would take this opportunity to thank our friends SURAJ J MOTWANI, BIJOY B JOHN, ARJUN KL and HARIKRISHNAN for helping us in completion of this article. Without helps of the particular that mentioned above, we would face many difficulties while doing this.

REFERENCES

- [1]. Safety measures for "Two wheelers by Smart Helmet and Four wheelers by Vehicular Communication" Manjesh N 1, Prof. Sudarshan raju C H 2 M Tech, ECE-DSCE, JNTUA, Hindupur Email: manjesh405@gmail.com HOD & Asst. Prof. BIT-IT, Hindupur International Journal of Engineering Research and Applications (IJERA) ISSN: 2248-9622 NATIONAL CONFERENCE on Developments, Advances & Trends in Engineering Sciences (NCDATES- 09th & 10th January 2015)
- [2]. Smart Helmet with Sensors for Accident Prevention Mohd Khairul Afiq Mohd Rasli, Nina Korlina Madzhi, Juliana Johari Faculty of Electrical Engineering University Tecnology MARA40450 Shah Alam Selangor, MALAYSIAjulia893@salam.uitm.edu.my)
- [3]. A Solar Powered Smart Helmet With Multifeatures Mr.P. Dileep Kumar¹, Dr.G.N.Kodanda Ramaiah² Mr.A.Subramanyam³, Mrs.M.Dharani⁴ International Journal of Engineering Inventions e-ISSN: 2278-7461, p-ISSN: 2319-6491 Volume 4, Issue 10 [June 2015] PP: 06-11)
- [4]. A Smart Safety Helmet using IMU and EEG sensors for worker fatigue detection Ping Li, Ramy Meziane, Martin J.-D. Otis, Hassan Ezzaidi, REPARTI Center, University of Quebec at Chicoutimi Chicoutimi, Canada Email: Martin_Otis@uqac.ca Philippe Cardou REPARTI Center, Laval University Quebec, Canada Email: pcardou@gmc.ulaval.ca)
- [5]. ISSN 2319 – 2518 www.ijeetc.com Vol. 4, No. 2, April 2015© 2015 IJEETC.
- [6]. Sudarsan K and Kumaraguru Diderot P (2014), "Helmet for Road Hazard Warning with Wireless Bike Authentication and Traffic Adaptive Mp3 Playback", International Journal of Science and Research (IJSR), Vol. 3, No. 3, ISSN (Online): 2319-7064.
- [7]. Vijay J, Saritha B, Priyadharshini B, Deepeka S and Laxmi R (2011), "Drunken Drive Protection System", International Journal of Scientific & Engineering Research, Vol. 2, No. 12, ISSN: 2229-5518.
- [8]. Harish Chandra Mohanta, Rajat Kumar Mahapatra and Jyotirmayee Muduli(2014)", Anti-Theft Mechanism System with Accidental Avoidance and Cabin Safety System for Automobiles", International Refereed Journal of Engineering and Science (IRJES), Vol. 3, No. 4, pp. 56-62.
- [9]. Smart Helmet & Intelligent Bike System Prof. Chitte P.P., Mr. Salunke Akshay S. , Mr. Thorat Aniruddha N. Mr. Bhosale Nilesh T. International Research Journal of Engineering and Technology (IRJET) e-ISSN: 2395 -0056 Volume: 03 Issue: 05 | May-2016