

# Modeling of Solar PV system under Partial Shading using Particle Swarm Optimization based MPPT

Ujjwala Rai<sup>1</sup>

<sup>1</sup> Assistant Professor, Dept. EED, SGSITS College, MP, INDIA

\*\*\*

**Abstract** - This work presents the effects of changing environmental conditions on the solar photovoltaic energy conversion system. Partial shading causes oscillations in output characteristics of the PV (photovoltaic) array and distracts the system to track MPP (maximum power point). In this paper, generalized approximate model of the solar cell is implemented using MATLAB/Simulink software package. In order to track maximum power efficiently from the PV array, evolutionary search technique PSO (particle swarm optimization) algorithm is used. Finally the developed model for PV array is interfaced with DC/DC boost converter using SimPowerSystems tool box to extract stepped up voltage from solar array. The duty cycle of the converter is controlled by the MPPT algorithm and PI (Proportional integral) controller. The PV array model is developed and simulated to produce higher output voltage under partial shading conditions.

**Key Words:** Solar photovoltaic systems, Partial shading, Maximum power point tracking (MPPT), Particle swarm optimization (PSO) algorithm, Boost converter.

## 1. INTRODUCTION

Due to the fact that conventional energy resources are in a state of diminution, there is a call for utilizing renewable energy resources to generate electrical energy worldwide. Solar energy is one of the promising natural resource that is used expansively to produce electricity globally using the concept of solar photovoltaic. Solar cell which is made up of P-N junction diode fabricated in a thin layer of semiconductor material is considered as the main fundamental unit for solar photovoltaic energy conversion system [1]. Since, solar cell alone cannot be used for high power generation, hence they are connected in series-parallel configuration to form modules and further these modules are connected as well to make array to get increased voltage. Solar insolation and temperature are the important factors that affect the output characteristics of the PV cell [2]. However, PV array operations suffer complexity in the output P-V characteristics under partial shading situation caused by the clouding, shadows of trees, obstruction of buildings, bird litters on the array and so forth. The total power in such an array is lower than the sum of the individual rated power of each module. When solar cells are connected in series, all the cells carry the same current. Although, a few cells under shade produce

less current, these cells are also forced to carry the same current as the other fully illuminated cells. The shaded cells may get reverse biased, acting as loads, draining power from fully illuminated cells [3]. The PV plants are being built in a fixed series-parallel configuration and each module is set with bypass diodes in anti-parallel. This is used to bypass the single module, when it may reduce the current of the whole photovoltaic array. The bypass diode across the group of cells will begin conducting when shading causes a cell to go far enough into reverse bias. The bypass diode allows current from part and limits the effects of shading to the only neighboring group of cells protected by the same bypass diode. This solution is easily adoptable and allowed to improve the energy production from the whole PV array. The characteristics of an array with bypass diodes differ from that of an array without diodes [3], [4]. Authors in [5] proposed a novel algorithm based on several critical observations made out of the PV characteristics and the behavior of the global and local peaks under partially shaded conditions. The proposed algorithm works in conjunction with a DC/DC converter to track the GP (global peak). In order to accelerate the tracking speed, a feed forward control scheme for operating the DC/DC converter is also proposed.

Under partial shading, the output P-V characteristic of the array exhibits local multiple peaks with one global peak which leads to a difficult form. Hence, it is necessary to apply MPPT technique as an interface between PV arrays and load so that the PV system always transfers maximum power to the load even in the changing environment. Many methods have been introduced to track the MPP and depend on its implementation complexity, sensed parameters, measurement required, cost, tracking speed, popularity, their application and other factors. Conventional MPPT methods operate very agreeably under uniform irradiance conditions, in which only a single MPP is to be detected. If multiple MPPs exist, these methods can easily be trapped at local maxima. Since the MPP controller detects the local MPP instead of the global MPP, efficiency of the PV system reduced significantly [6]-[7]. In order to solve this problem, a MPPT algorithm based on Particle Swarm Optimization that is capable of tracking global MPP under partial shaded conditions is implemented in this paper. Reference [8] proposed PSO algorithm with the capability of direct duty cycle is used to track the MPP of a PV system under partially shaded conditions. Simulations are being carried out under various insulations and loading conditions and the performance is compared with the Hill climbing method,

then a buck-boost converter is interfaced with the whole PV array. Reference [9] proposed PSO technique to control several PV arrays with one pair of voltage and current sensors. The multidimensional search based technique is able to detect the global MPP and also compared some other MPP techniques with PSO technique. Reference [10] presented a hybrid algorithm of PSO and Artificial Neural Network (ANN) MPPT algorithm for the detection of global peak among multiple peaks occurs in the PV output characteristics. Reference [11] presented PSO and PSO combined with Incremental conductance algorithm to track MPP, modeling of a PV module along with an innovative procedure to optimize the performance and efficiency of the MPPT algorithm and comparison of SPV (solar photovoltaic) panel output with and without optimization is also presented. Reference [12] presented an extraction of maximum energy from SPV array by optimal selection of array size using PSO technique. The algorithm is tested for different set of input insolation and temperature patterns; analysis of various SPVA configurations with respect to environment parameters by developing a more realistic model using MATLAB M-file has been presented. Reference [13] presented complexity in output characteristics of PV array by analyzing different shading situations. This is done by simulation in MATLAB/Simulink and experimentally on two commercial panels. Reference [14] presented a power electronic circuit oriented model with one diode circuit modeling of PV module. The model is realized using power system block set under MATLAB/Simulink. The developed model is integrated with standard power electronic model of DC/DC boost converter. Reference [17] proposed a novel smart-PID controller for optimal control of DC-DC boost converter used as voltage controller in PV systems has been presented.

## 2. SOLAR PV ARRAY MODELING

The equivalent circuit of a solar cell contains a current source in parallel with a diode; in practice no solar cell is ideal, so a shunt resistance ( $R_{SH}$ ) and a series resistance ( $R_S$ ) component are added to the circuit as shown in Fig. 1.

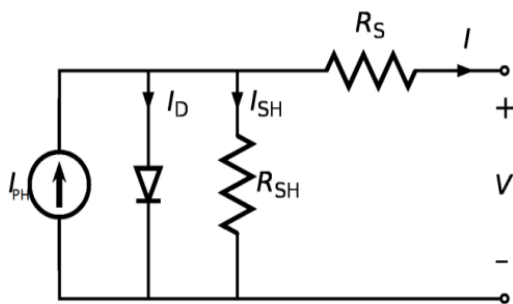

Fig. 1 Equivalent circuit of solar cell

A PV cell generates less than 2W at 0.5V-0.8V. Therefore, for high power generation, PV cells are connected in series

–parallel to form PV module and array. The value of parallel resistance  $R_{SH}$  is generally very large and hence neglected to simplify the model [1]. The circuit diagram for approximate model is shown in Fig. 2.

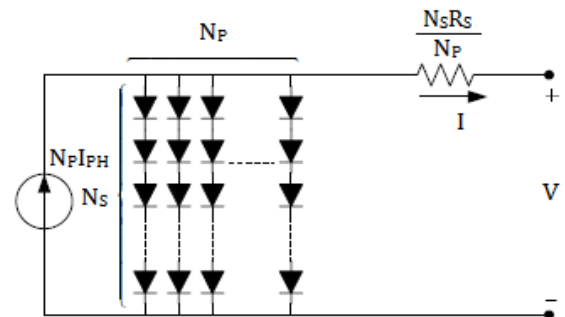

Fig. 2 Generalized approximate array model

The generalized PV module can be modeled mathematically by using MATLAB/Simulink software package by the following equations [1], [2].

Module Photocurrent  $I_{PH}$ :

$$I_{PH} = [I_{SC} + \mu(T_k - T_{ref})] * G/1000 \quad (1)$$

Module Reverse Saturation Current  $I_{RS}$ :

$$I_{RS} = I_{SC} [(exp(qV_{oc}/N_s k A T_k) - 1)] \quad (2)$$

Module Saturation Current  $I_S$  or diode current:

$$I_S = I_{RS} [T/T_{ref}]^3 exp [q * E_g A k \{1/T_{ref} - 1/T_k\}] \quad (3)$$

Module Output Current  $I_{PV}$ : The mathematical equation of output current of PV module for generalized approximate model can be described as:

$$I_{PV} = N_p * I_{PH} - N_p * I_S [exp\{q * (V_{PV} + I_{PV} R_S) / N_s A k T\} - 1] \quad (4)$$

Where,

$I_{PH}$ : Light generated current or photocurrent

$I_{SC}$ : Cell's short-circuit current

$\mu$ : Temperature coefficient for  $I_{SC}$

$T_k$ : Actual cell's temperature in Kelvin

$T_{ref}$ : Reference temperature in Kelvin

$G$ : Solar irradiation ( $W/m^2$ )

$I_{RS}$ : Cell's reverse saturation current at a reference temperature and a solar radiation

$A$ : Ideality factor (1.3) depends on PV technology [1]

$I_{PV}$ : Output current

$V_{PV}$ : Output voltage

$I_S$ : Cell saturation of dark current

$E_g$ : Band-gap energy for silicon (1.1eV)

$q$ : Electron charge =  $1.6 \times 10^{-19}$  C

$k$ : Boltzmann's constant =  $1.38 \times 10^{-23}$  J/K

$R_S$ : Series resistance (0.1 $\Omega$ )

**Table I:** Electrical characteristics data of Solkar 36 W PV module ratings

Rated power	37.08Wp
Voltage at maximum power ( $V_m$ )	16.56V
Current at maximum power ( $I_m$ )	2.25A
Open circuit voltage ( $V_{OC}$ )	21.24V
Short circuit current ( $I_{SC}$ )	2.55A
Temperature coefficient for $I_{SC}$ ( $\mu$ )	0.0017(A/K)
Number of cells in series ( $N_s$ )	36
Number of cells in parallel ( $N_p$ )	1

The electrical specifications are under standard test conditions (STCs) which means an irradiation of 1000 W/m<sup>2</sup> with an AM 1.5 spectrum at 25°C.

Mathematical modeling for PV module is done by using above four equations which takes solar insolation, temperature and PV output voltage  $V_{PV}$  (varies from 0 to  $V_{OC}$ ) as inputs and calculates  $I_{PV}$ . To interface the mathematical PV model with the power system toolbox, PV model output current has been fed to a DC controlled current source and the output voltage has been measured then fed back into the voltage input of the PV panel as shown in Fig. 3.

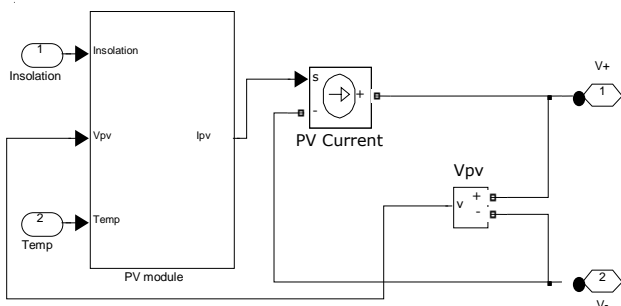
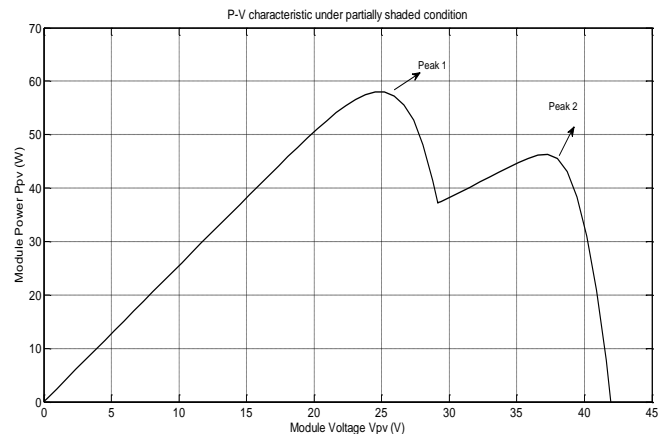

**Fig. 3** Interfacing mathematical PV module model to physical parts

Fig. 4 shows simulation of 2x1 PV array consists of four groups G1A, G1B, G2A, and G2B connected in series. Each one of the groups is connected across one bypass diode in anti-parallel. To study the effect of partial shading, G1A is partially illuminated with 500W/m<sup>2</sup> and other three groups are fully illuminated (receiving 1000 W/m<sup>2</sup>). When the PV modules are connected in series, they will conduct the same current but the voltage across them will be different. Fig. 5 and Fig. 6 shows resulting P-V and I-V characteristic curves having multiple peaks and stairs in curves respectively.

### III. PROPOSED MPPT METHOD

To track the maximum power from the output P-V characteristics of the PV array, Particle swarm optimization algorithm is used and further output voltage from PV array used as DC controlled voltage for the DC/DC boost converter.



**Fig. 5** P-V characteristic curve for 2x1 PV array

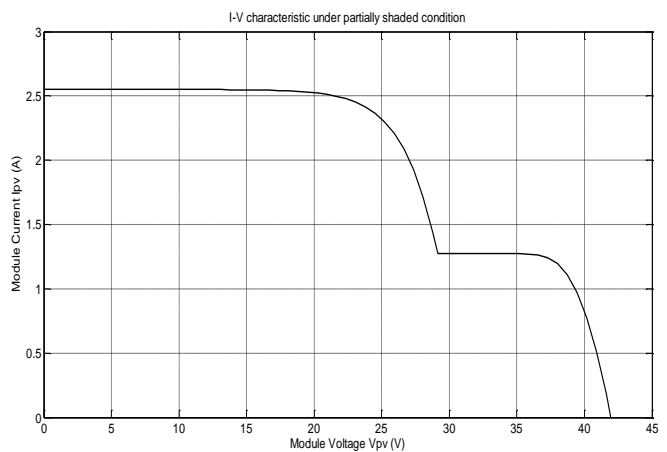

**Fig. 6** I-V characteristic curve for 2x1 PV array

### A. Particle Swarm Optimization

PSO was originally developed by James Kennedy and Russell C. Eberhart in 1995 [15], it is a population-based evolutionary search algorithm. The principle of PSO is inspired by choreography of fish schooling and bird flocking. Natural creatures sometimes behave as a swarm. The PSO maintains a swarm of particles and each particle represents a potential solution in the swarm. PSO determines the required parameters that maximizes or minimizes the objective function in a given search space. Each individual particle has a current position, a current velocity, and a personal best position in search space. The personal best position  $pbest_i$  corresponds to the position in search space where particle had the largest value as determined by the objective function  $F$ , considering a maximization problem. In addition, the position yielding the highest value amongst all the personal best is called the global best position which is denoted by  $gbest$  [16]. The following equations (5) and (7) define how the personal and global best values are updated, respectively.

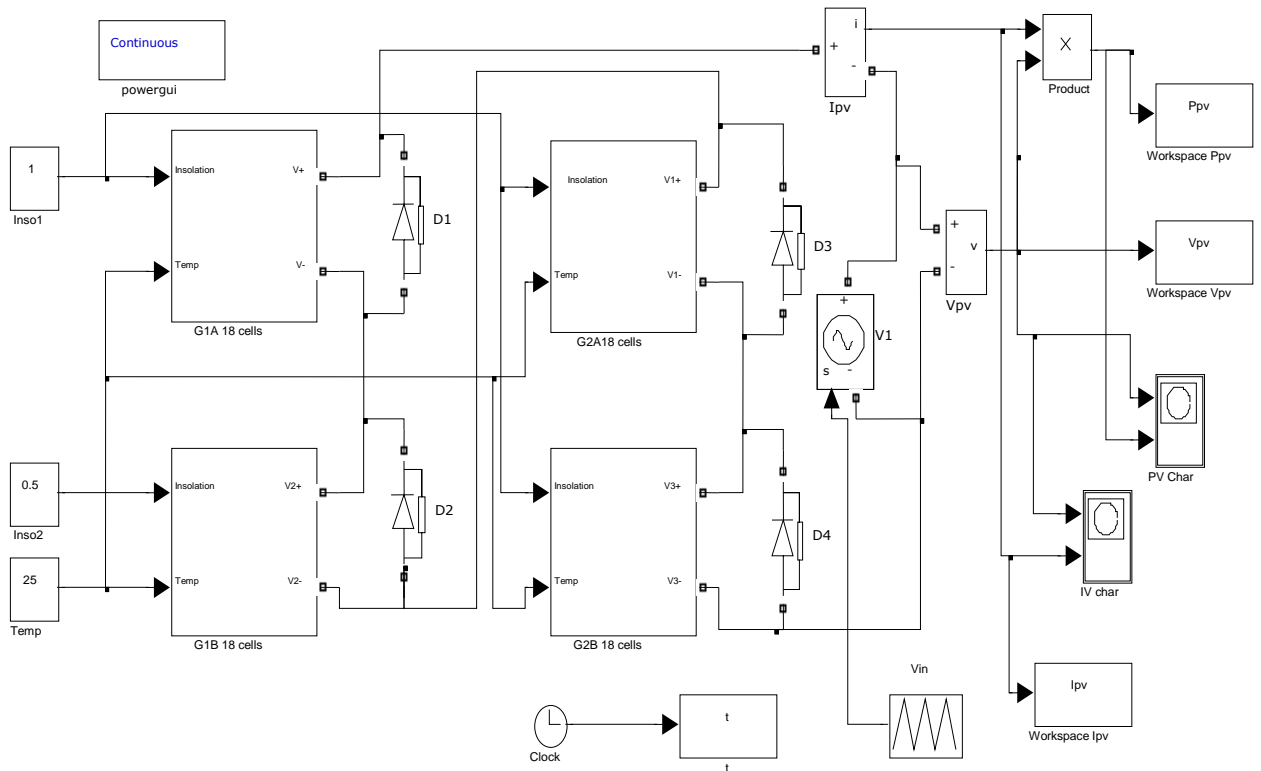

Fig. 4 Simulink model for 2×1 PV array

After that a loop starts to find the optimal solution.  $pbest_i$  is updated as (5) if the condition (6) is fulfilled

$$pbest_i = S^{k_i} \tag{5}$$

$$F(S^{k_i}) > F(pbest_i) \tag{6}$$

Where,  $F$  is the objective function that should be maximized. On the other hand, the global best position is the best position discovered by any of the particles in the entire swarm.

$$Gbest = \max (pbest_i) \tag{7}$$

All particles fly through a multidimensional search space where is adjusting its position according to its own experience and that of neighbors. However, each particle constantly updating a velocity vector based on best solutions found so far by that particle as well as others in the swarm. The velocity and position of the particles will be updated according to equations as follows:

$$V^{k_{i+1}} = \omega V^{k_i} + c_1 r_1 (P^{k_i} - V^{k_i}) + c_2 r_2 (P^{k_g} - X^{k_i}) \tag{8}$$

$$X^{k_{i+1}} = V^{k_{i+1}} + X^{k_i} \tag{9}$$

Where,

- $i = 1, 2, 3, \dots, N$ ,
- $N$ : no. of particles,
- $k = 1, 2, 3, \dots, Iter_{max}$ ,
- $Iter_{max}$ : no. of iterations,
- $X^{k_i}$  or  $S^{k_i}$ : current position of particle,
- $X^{k_{i+1}}$  or  $S^{k_{i+1}}$ : modified position of particle,
- $X^{k_i}$  or  $pbest_i$ : local best position found by particle  $i$ ,
- $P^{k_g}$  Or  $gbest$ : global best position found by particle group,
- $V^{k_i}$ : current velocity of particle,
- $V^{k_{i+1}}$ : modified velocity of particle,
- $r_1, r_2$ : random number between 0 & 1,
- $c_1$ : cognitive coefficient,
- $c_2$ : social coefficient,
- $\omega$ : inertia weight.

Inertia weight  $\omega$  is set according to the following equation

$$\omega = \omega_{max} - (\omega_{max} - \omega_{min}) / Iter_{max} \times Iter \tag{10}$$

Where,  $\omega_{max}, \omega_{min}$  are initial, final weights.

### B. PSO applied to MPPT

The PSO algorithm explained in the earlier section is now applied to realize the MPPT control of the PV system, wherein the P-V characteristic exhibits multiple local MPP. In order to operate a solar array within its MPP, a MPPT method is needed to track and maintain the peak power,

find the voltage or current on which the solar array provides the maximum output power. To start the optimization, a solution vector of module voltages ( $V_1, V_2 \dots V_D$ ) must be controlled, where,  $D$  being the number of modules. Now, non-linear optimization problem can be stated as

$$X = (V_1, V_2, V_3 \dots V_D); F(X) = \text{Array power } P_{PV}$$

Here, PSO is used to find the optimal voltage  $V_D$  for which the objective function  $F(X)$  that is array power has a maximum value, each one of the system modules must be controlled in such a way that their terminal voltages are equal to the corresponding MPPT voltages and their magnitude vary between 0 to  $V_{OC}$ . The PV array voltage  $V_{PV}$  is constrained to  $(0.05 V_{OC} < V_i < 0.85 V_{OC})$ . Where,  $V_{OC}$  is the open circuit voltage of each module and  $i=1,2,3 \dots D$ . The code for PSO has been written in MATLAB, the parameters used for PSO program is presented in table II.

Table II: Parameters used for PSO algorithm

PARAMETERS	VALUES
No. of particles ( $N$ )	10
No. of dimensions ( $D$ )	1 or 2
Maximum velocity ( $V_{max}$ )	2.70
No. of iterations ( $Iter_{max}$ )	80
$\Delta P$	0.15
$c_1$	1.6
$c_2$	1.2
$\omega_{max}$	0.9
$\omega_{min}$	0.4
$r_1, r_2$	$0 < r_1, r_2 < 1$

The objective function  $F$  changes due to varying environmental conditions. Hence, for that condition agents must be reinitialized to search for the new MPP again whenever the following condition is fulfilled.

$$\frac{|P_{(S_{i+1})} - P_{(S_i)}|}{P_{(S_i)}} > \Delta P \tag{11}$$

Where,  $\Delta P$  denotes the change in power whose value is determined by hit and trial. The flow chart for the proposed PSO algorithm is shown in Fig 7.

#### IV. SIMULATION

Modeling and simulation of the system has been done in MATLAB/Simulink. It consists of  $2 \times 1$  PV array, a DC/DC boost converter for which duty cycle is controlled by PSO MPPT technique via PI controller, and a resistive load. Two PV modules are divided into four groups each consists of 18 cells is connected in series. Each group is connected across a bypass diode. Out of the four groups, three are fully illuminated ( $1 \text{ kW/m}^2$ ) and one group is partially shaded receiving solar irradiation of  $0.5 \text{ kW/m}^2$ . Inputs to the PV array are solar insolation, temperature and PV

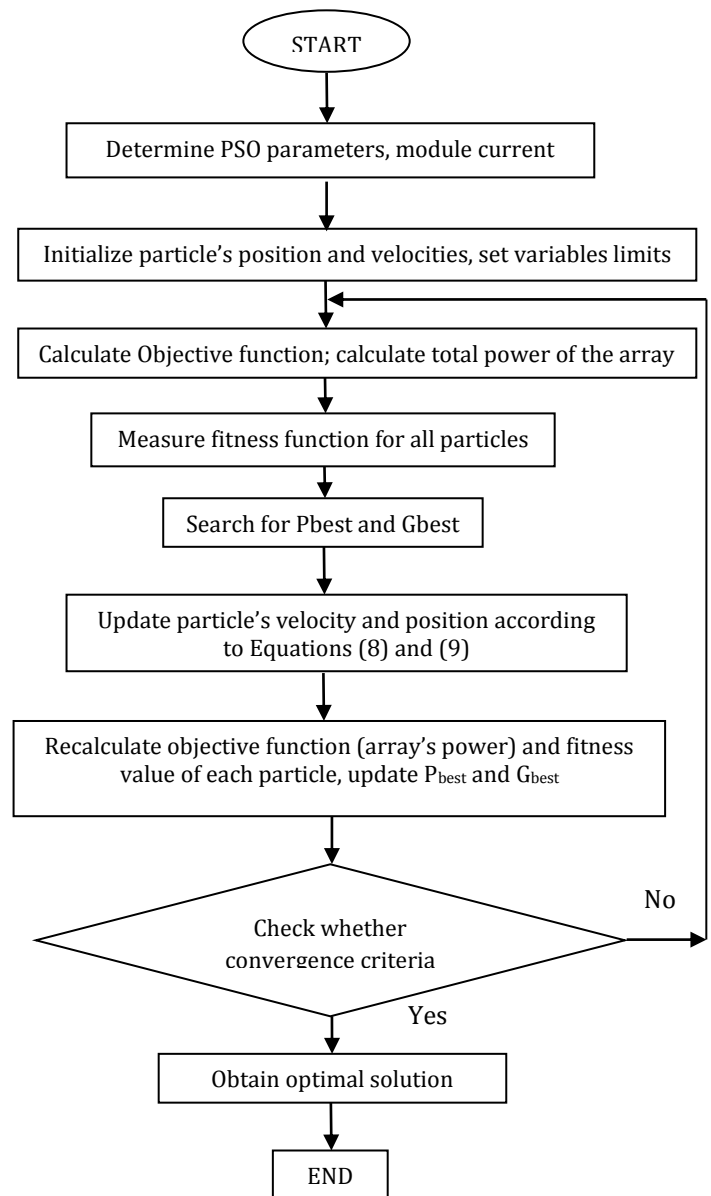

Fig. 7 Flow chart for proposed PSO algorithm

voltage. PV array generates PV voltage  $V_{PV}$  which acts as a controlled voltage source for boost converter. The DC/DC boost converter consists of MOSFET switch, an inductor  $L$  of  $120 \text{ mH}$ , capacitor  $C_2$  of  $750 \mu\text{F}$  and a load resistance  $R$  of  $250 \Omega$ . Another input filter capacitor  $C_1$  of  $15 \mu\text{F}$  is connected across PV array to reduce fluctuations in generated PV voltage. The switch was controlled by a Pulse width modulation (PWM) technique with switching frequency of  $20 \text{ kHz}$ . Inputs to the MPPT block are PV current and voltage. Actual output voltage  $V_{PV}$  obtained from PV panel is compared with the optimal voltage  $V_{optimal}$  obtained from the PSO based MPPT technique so that solar PV panel works with optimal voltage and maximum power. This error signal from the comparator is then inserted to a PI (Proportional integral) controller. The

output from controller which is the control signal is then compared with the high frequency signal of 20kHz to generate the PWM signal which is fed as gate signal to the MOSFET switch S. Fig. 8 shows the proposed model. Meanwhile, the values of  $K_p$  and  $K_i$  are determined by hit and trial method.

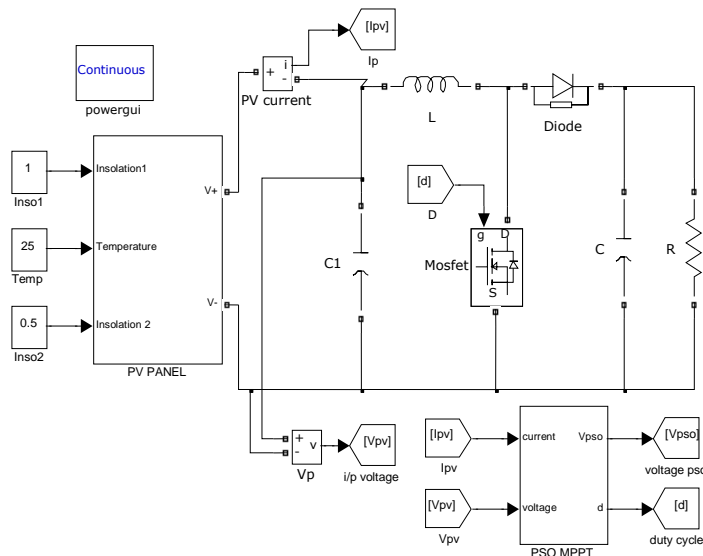

Fig. 8 MATLAB/Simulink model for proposed solar PV energy conversion system

## V. RESULTS AND DISCUSSION

Fig. 9 shows the characteristics curve of PSO power obtained with the iterations from the proposed MPPT. The curve is drawn between the Fgbest value that is maximum power and the iterations carried out. It is observed from figure that in spite of having multiple peaks in PV output power curve, PSO MPPT easily tracks the maximum power of 58.07W after certain number of iterations.

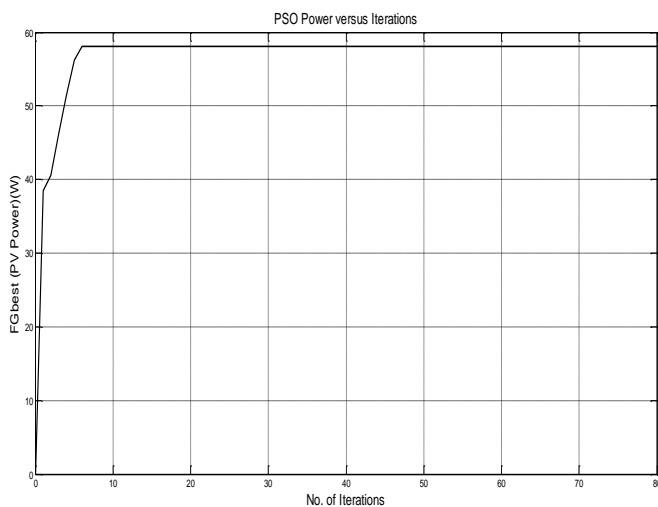

Fig. 9 Power tracking curve from PSO controller

Fig. 10 (a) shows the output waveforms for PV current, PV voltage and power from the PV array. The output voltage obtained is 25.74V, output current is 2.34A, and output power is 58.05W. Figure 10 (b) shows the output waveforms for output voltage, current and power obtained from boost converter. It is shown from figure that increased output voltage obtained is approximate constant DC voltage of 115.7V which accordingly increase the duty ratio of the converter.

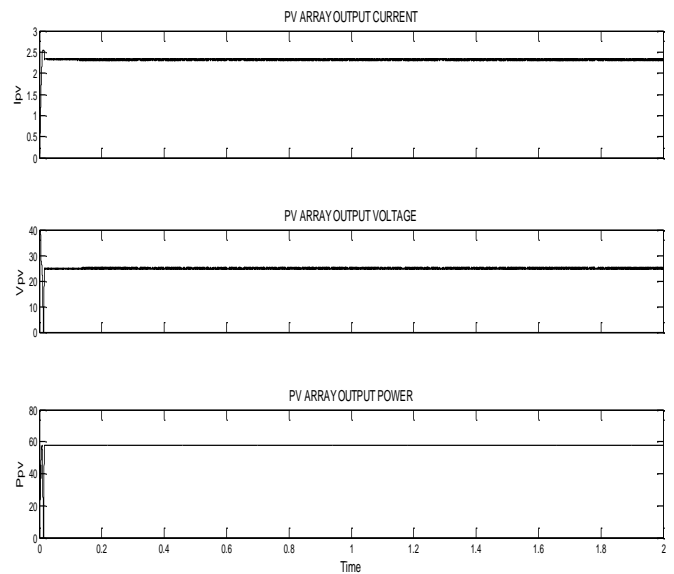

Fig. 10(a) Output waveforms from PV array using PSO algorithm

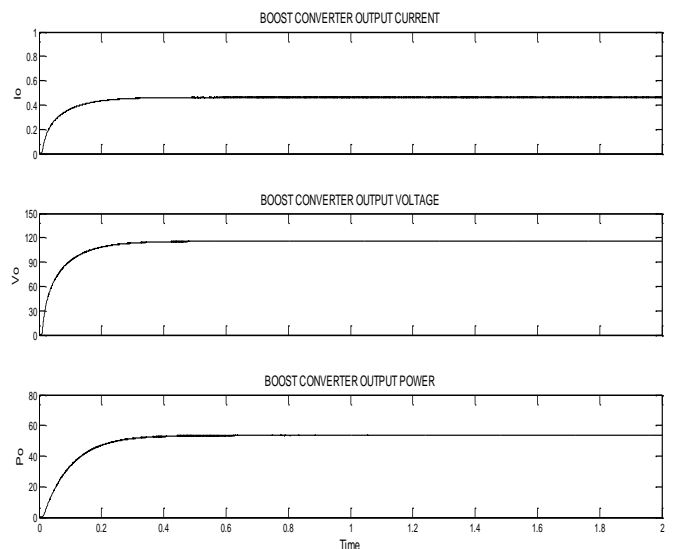

Fig. 10(b) Output waveforms from Boost converter

## VI. CONCLUSION

Proposed work provides an efficient solar photovoltaic energy conversion system under partial shading

conditions. Mathematical modeling of solar PV module using MATLAB/Simulink software package has successfully done. Particle swarm optimization based MPPT is used to track global maximum power from SPVA under partial shading condition. It is concluded that PSO technique is simple, fast and easily adoptable. Outputs obtained concluded that it works efficiently and is able to track correct peak of the power with reliability. Finally, a DC/DC boost converter is interfaced with developed SPVA model, where duty cycle is controlled by PSO MPPT and PI controller. It is observed from output waveforms that PV power remain almost constant and output boost voltage increases. Developed scheme provides an efficient and accurate way to implement high power solar PV array configuration for various loading conditions.

## REFERENCES

- [1] H.L. Tsai, C.S. Tu, and Y.I. Su, "Development of generalized photovoltaic model using MATLAB/SIMULINK," Proceedings of the World Congress on Engineering and Computer Science, October 22 - 24, 2008.
- [2] S. Said, A. Massoud, M. Benammar and S. Ahmed, "A Matlab/Simulink-based photovoltaic array model employing SimPowerSystems toolbox," Journal of Energy and Power Engineering, 6, 1965-1975, 2012.
- [3] H. Patel and V. Agarwal, "MATLAB-based modeling to study the effects of partial shading on PV array characteristics," *IEEE Transactions on Energy Conversion*, 23, 302-310, 2008.
- [4] R. Ramaprabha and B. L. Mathur, "A comprehensive review and analysis of solar photovoltaic array configurations under partial shaded conditions," Hindawi Publishing Corporation International Journal of Photoenergy, vol. 2012, pp. 1-16, February 2012.
- [5] H. Patel and V. Agarwal, "Maximum power point tracking scheme for PV systems operating under partially shaded conditions," *IEEE Transactions on Industrial Electronics*, vol. 55, no. 4, pp. 1689-1698, 2008.
- [6] T. Eram, P. L. Chapman, "Comparison of photovoltaic array maximum power point tracking techniques," *IEEE Transaction on Energy Conversion*, vol. 22, no. 2, pp. 439-449, 2007.
- [7] N. A. Ahmed and M. Miyatake, "A novel maximum power point tracking for photovoltaic applications under partially shaded insolation conditions," *Electric Power System Research*, vol. 78, no. 5, pp. 777- 784, 2008.
- [8] K. Ishaque, Z. Salam, M. Amjad, and S. Mekhilef, "An improved particle swarm optimization (PSO)-based MPPT for PV with reduced steady-state oscillation," *IEEE Transactions on Power Electronics*, vol. 27, no. 8, August 2012.
- [9] M. Miyatake, M. Veerachary, F. Toriumi, N. Fujii, H. Ko, "Maximum power point tracking of multiple photovoltaic arrays: A PSO Approach," *IEEE Transactions on Aerospace and Electronic Systems*, vol. 47, no. 1, 2011.
- [10] M. Shan Ngan, Chee Wei Tan, "Multiple peaks tracking algorithm using particle swarm optimization incorporated with artificial neural network," World Academy of Science, Engineering and Technology, vol. 58, October 2011.
- [11] Raal Mandour, I. Elamvazuthi, " Optimization of maximum power point tracking (MPPT) of photovoltaic system using artificial intelligence (AI) algorithms," *Journal of Emerging Trends in Computing and Information Sciences*, vol. 4, no. 8, August 2013.
- [12] R. Ramaprabha, "Selection of an Optimum Configuration of Solar PV array under partial shaded condition using particle swarm optimization," World Academy of Science, Engineering and Technology International Journal of Electrical, Electronic Science and Engineering, vol. 8, no. 1, 2014.
- [13] Basim A. Alsayid, Samer Y. Alsadi, Ja'far S. Jallad, Muhammad H. Dradi, "Partial shading of PV system simulation with experimental results," *Smart Grid and Renewable Energy*, 4, 429-435, September 2013.
- [14] N. Pandiarajan, R. Ramaprabha, and R. Muthu, "Application of circuit model for photovoltaic energy conversion system," Hindawi Publishing Corporation International Journal of Photoenergy, vol. 2012, pp. 1-14, November 2011.
- [15] J. Kennedy and R. Eberhart, "Particle swarm optimization," Proceedings of IEEE International Conference on Neural Networks (ICNN'95), vol. 4, pp. 1942-1948, 1995.
- [16] X. Li and K. Deb, "Comparing lbest PSO Niching algorithms using different position update rules," in Proceedings of the IEEE World Congress on Computational Intelligence, Spain, pp. 1564-1571, 2010.
- [17] M. Elshaer, A. Mohamed, and O. Mohammed, "Smart optimal control of DC-DC boost converter in PV systems," *IEEE/PES Transmission and Distribution Conference and Exposition: Latin America*, 2010.