

# USING RASPBERRY PI TO SENSE TEMPRATURE AND RELATIVE HUMIDITY

Shah Vatsal<sup>1</sup>, Mehta Bhavin<sup>2</sup>

<sup>1</sup>Student, Dept. Of Mechanical Engineering, CHARUSAT, Changa, INDIA

<sup>2</sup>Assistant Professor, Dept. Of Mechanical Engineering, CHARUSAT, Changa, INDIA

\*\*\*

**Abstract** -This paper presents the detection of real time temperature and relative humidity employing raspberry pi. This is a raspberry pi based temperature and humidity logger that uses DHT22 sensor for measurement and it is unique as it not only reads temperature from sensor but also stores data to mysql database and provide means to read that temperature data with any web enabled device (computer,phone)web browser. Python language is used.

**Key Words:** Python, Raspberry pi, DHT22 temperature sensor, mysql database

## 1.INTRODUCTION

Temperature has an impact on almost all the activities surrounding us[2]. A precise determination of temperature and more importantly relative humidity is a vital factor in countless industries and different fields of science. The temperature monitoring is crucial in lot of industries, like food industry, the workshop and pharmaceutical industry. Analog and digital Temperature sensors are available for sensing temperature for commercial purpose. Temperature sensors possessing temperature-dependent properties that can be measured electrically contain resistors, semiconductor mechanisms such as diodes, thermocouples, thermistors. This project aims at monitoring the real time temperature and relative humidity in a cost effective way. Here the monitoring node is raspberry pi. Programming language used for raspberry pi is Python. The Sensor utilized here is DHT22 temperature sensor. This sensor consists of thermistor and basic advantage of using DHT22 sensor is that it is economical and light in weight. The sensor is interfaced with the raspberry pi using jumper wires. The temperature is sensed using the sensor DHT22 and is read, stored and displayed by the raspberry pi kit.

## 2. Raspberry pi

The Raspberry Pi is a low cost, credit-card sized computer which plugs into a computer monitor or TV, and requires a standard keyboard and mouse. **Raspberry Pi** is a dynamic microcontroller and runs with the **Python** programming language. **Raspberry Pi 2** includes a quad-core Cortex A7 processor CPU running at 900 MHz and 1 GB RAM, Integrated Video core 4 Graphics Processing

Constituent (GPU) capable of frolicking Maximum 1080p Elevated Meaning Blu-Ray Quality Video,512Mb SDRAM, The free, flexible and exceedingly builder approachable Debian GNU/Linux(RASPBIAN)Operating System, 2 x USB Ports, HDMI Video Output, RCA Video Output,3.5mm Audio Output Jack,10/100Mb Ethernet Port for Internet Access, 5V Micro USB Domination Input Jack, Micro SDHC card, MMC,40 gpio pins[2]. It has capability of a little device that allows people of all ages to explore computing. It's capable of doing everything you would expect a desktop/computer to do, from browsing the internet and playing high-definition video to making spreadsheets, word processing, and playing games . The Raspberry Pi has the ability to interact with the outside world, and has been used in a wide array projects like smart home monitoring system, wireless motion sensor activated light and many more.

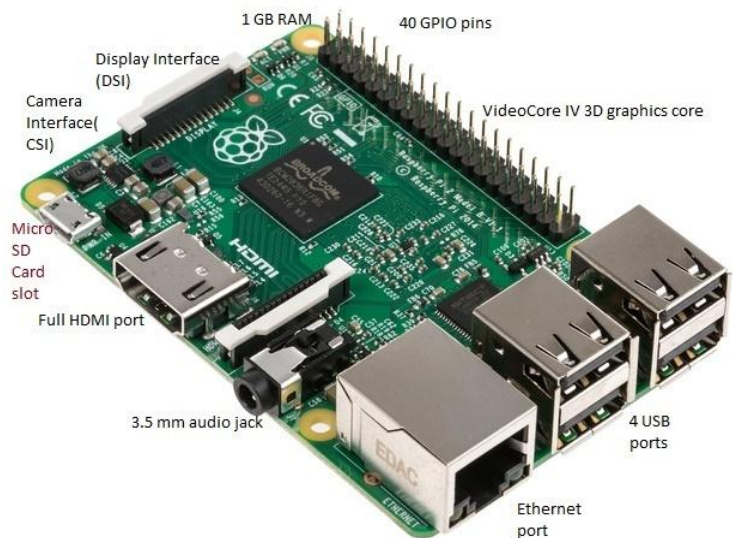
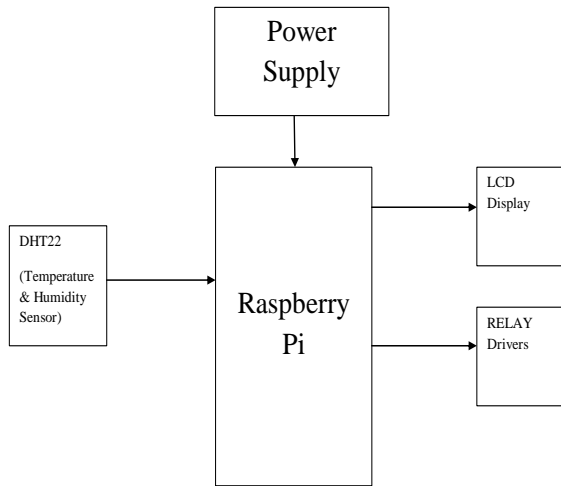

Fig-1: Raspberry pi 2 model b

### 3. Flow chart of Circuit system



### 4. Proposed system

The proposed method aims at continuously monitoring the real time temperature and relative humidity in a cost effective way by polling sensor at fixed interval of time. Here the monitoring node is raspberry pi[1].The Sensor utilized here is DHT22 Temperature/Humidity Sensor.The sensor is connected to the raspberry pi kit using jumper wire.The raspberry pi kit can be used to store and display the real time temperature and relative humidity.The raspberry kit is programmed using python language. The block diagram of the proposed method is shown in figure below.The temperature is displayed in degree celsius or Fahrenheit as required.To know the current temperature and relative humidity at remote location, the user can log in on web browser by entering username and password by the user.Web application opens after entering password and with the output graphical representation can also be obtained. Raspberry pi processed data will be updated continuously on cloud server & user will get to know the stored data on hourly and daily basis.Wireless wifi (mini USB adapter)is attached so that it fetches data with the help of internet and user can access or control temperature and humidity from any part of the world.

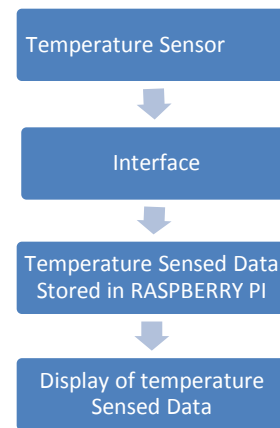

Fig-2:block diagram of proposed system

### 5. Working methodology

#### 5.1 Requirements of the project

This project is built on a breadboard, so no need to worry about soldering, or a designing PCB.

Hardware:

- Raspberry PI 2
- 16 GB micro SDHC(CLASS10) CARD
- USB Power Supply
- USB Cable
- Breadboard & Jumper Wires
- DHT22 sensor
- 10k resistor (one per sensor)

First of all Raspberry pi has to be prepared and for that we require NOOBS. NOOBS, short for New Out of the Box Software. It's an operating system manager that makes it easy to download, install, and set up your Raspberry Pi. When you first boot up NOOBS, you'll get a selection of OSes to choose from.NOOBS makes getting started with Pi easy, and includes a bunch of different operating systems to choose from.The Raspberry Pi itself doesn't come with an operating system,we need to select it while booting of NOOBS.Raspbian is the "official" operating system of the Raspberry Pi. Raspbian has been the standard Raspberry Pi operating system.Raspbian is a version of Linux built specifically for the Raspberry Pi.

Here raspberrypi 2 model b has been used.

### 5.2 NOOBS installation

1. Insert an SD card that is 4GB or greater in size into your computer.

2. Format the SD card using the platform-specific instructions below:

a. Windows

i. Download the SD Association's Formatting Tool from [https://www.sdcard.org/downloads/formatter\\_4/eula\\_windows/](https://www.sdcard.org/downloads/formatter_4/eula_windows/)

ii. Install and run the Formatting Tool on your machine

iii. Set "FORMAT SIZE ADJUSTMENT" option to "ON" in the "Options" menu

iv. Check that the SD card you inserted matches the one selected by the Tool

v. Click the "Format" button

3. Extract the files contained in this NOOBS zip file.

4. Copy the extracted files onto the SD card that you just formatted so that this file is at the root directory of the SD card. Please note that in some cases it may extract the files into a folder, if this is the case then please copy across the files from inside the folder rather than the folder itself.

5. Insert the SD card into raspberry Pi and connect the power supply.

Raspberry Pi will now boot into NOOBS and should display a list of operating systems that you can choose to install.

If your display remains blank, you should select the correct output mode for your display by pressing one of the following number keys on your keyboard:

- 1. HDMI mode - this is the default display mode.
- 2. HDMI safe mode - select this mode if you are using the HDMI connector and cannot see anything on screen when the Pi has booted.

### 5.3 Download the Python program that will poll the sensor(s) dht22.py

**dht22.py** is used for monitoring temperature and humidity using the DHT22 sensor. Once your Raspberry Pi is up and running we setup Python to talk to the GPIO pins. The GPIO pins are our interface to the DHT22 Temperature/Humidity sensor. Not all the libraries we need to make this project are pre-loaded on the Raspberry Pi. We require the Adafruit GPIO Python library and the Adafruit DHT22 library. For more details visit following link.

<http://projects.privateeyepi.com/home/home-alarm-system-project/temperature-and-humidity>

### 5.4 Building the circuit

- Connect Pin 1 of the sensor to 5V GPIO (Pin 2).
- Connect Pin 2 of the sensor to and free GPIO pin e.g. GPIO4 (Pin 7).
- Ignore pin 3.
- Connect Pin 4 of the temperature gauge to ground (Pin 6).
- put the resistor between pins 1 and 2 [3].

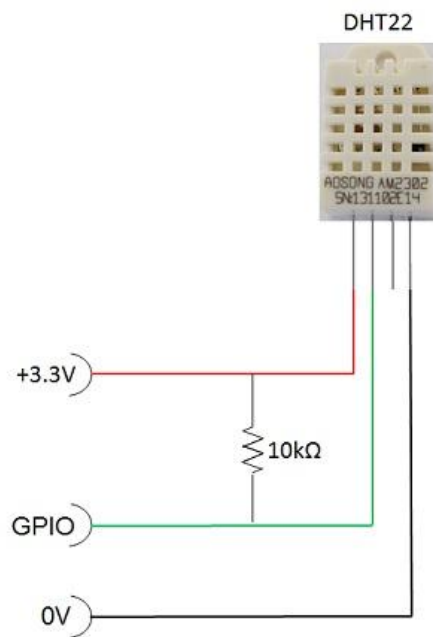



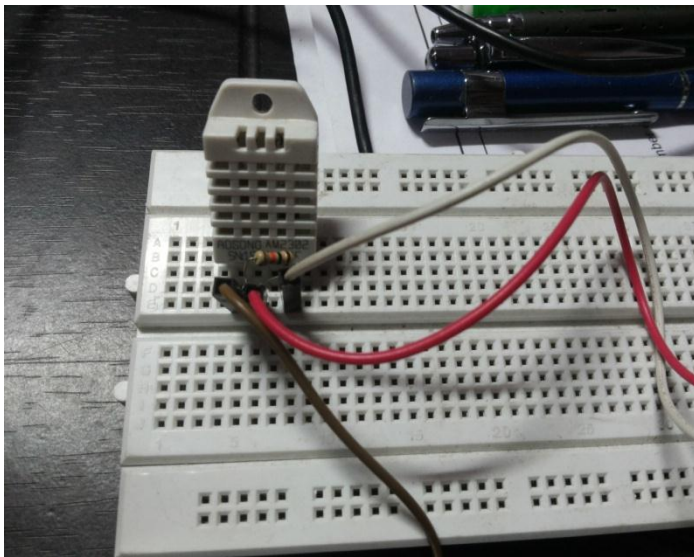

Fig-3:connection of sensor with raspberry pi

### 6. About GPIO Pins

We are keeping the circuit simple and building it on a breadboard using our components and jumper wires. Before connecting anything to your Raspberry Pi, disconnect the power.

Warning - you can destroy your Raspberry Pi with a short circuit from a wrong connection. Just be careful and double check everything before powering back on.

All the connections were carefully checked and connected. Since, a little careless mistake may short-circuit the RaspberryPi circuit.

The DHT 22 has 4 Pins. Pin 1 is VCC, Pins 2 is Data, Pin 3 is NOT USED, Pin 4 is Ground.

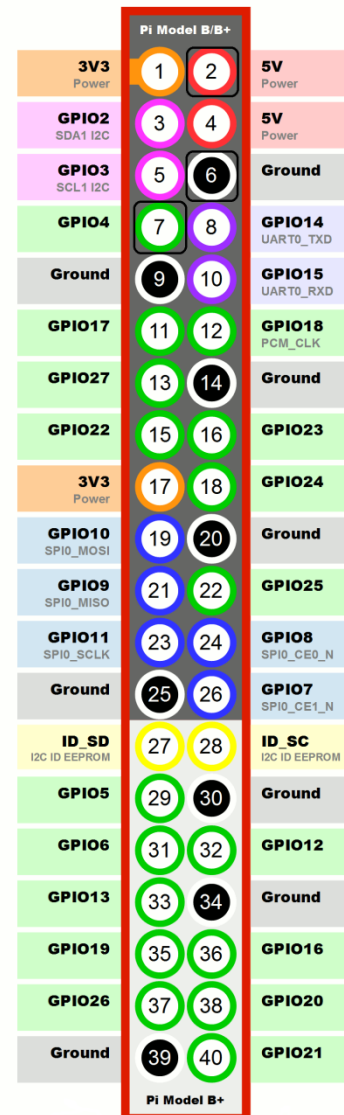

Fig-4:General Purpose Input Output(GPIO)pin schematic diagram

### 7. Why python

Also other languages like C language,C++,JAVA can be used but python is used for current application as it has following advantages:

Python programs are typically 3-5 times shorter than equivalent Java programs. This difference can be attributed to Python's built-in high-level data types and its dynamic typing.Python is designed to be highly readable . Python is a simplest, dynamic, interpreted, object oriented language[4]. Python interpreters allowing Python code to run on a wide variety of systems.

### 8. RESULTS and CONCLUSIONS

With the proposed methodology, we were able to interface and synchronize the Raspberry Pi. Consequently, we with help of privateeyepi software, we were able to observe the requisite graphs and results. Therefore, a novel method of Sensing Temperature and humidity was reviewed.

Hourly Sensor Report <span style="float: right;">2017-01-26</span>					
Hour	Sensor	Temperature	Humidity	Logs	Alarms
5 PM	Temperature Gauge	27.50C to 28.20C	35.50% to 38.10%	5	
6 PM	Temperature Gauge	27.20C to 27.50C	35.30% to 36.60%	12	
7 PM	Temperature Gauge	22.60C to 27.20C	29.10% to 38.30%	12	
8 PM	Temperature Gauge	22.00C to 24.60C	30.50% to 36.30%	7	

```

File Edit Tabs Help
https://www.privateeyepi.com/alarmhostr.php?u=svatsal96@yahoo.com&p-Maha
function=21&opcode0=0
7.Temperature Gauge.29.6./n
[[7, 'Temperature Gauge', '29.6']]
Location Description = Temperature Gauge
Reading DHT22 sensor on pin 7
Temperature = 28.2
Humidity = 38.1
Host Update: https://www.privateeyepi.com/alarmhostr.php?u=svatsal96@yahoo
-Mahavir@123&function=14&opcode0=28.2&opcode1=0&opcode2=7&opcode3=38.1

Reading DHT22 sensor on pin 7
Temperature = 28.0
Humidity = 36.9
Host Update: https://www.privateeyepi.com/alarmhostr.php?u=svatsal96@yahoo
-Mahavir@123&function=14&opcode0=28.0&opcode1=0&opcode2=7&opcode3=36.9

Reading DHT22 sensor on pin 7
Temperature = 28.0
Humidity = 35.5
Host Update: https://www.privateeyepi.com/alarmhostr.php?u=svatsal96@yahoo
-Mahavir@123&function=14&opcode0=28.0&opcode1=0&opcode2=7&opcode3=35.5
    
```

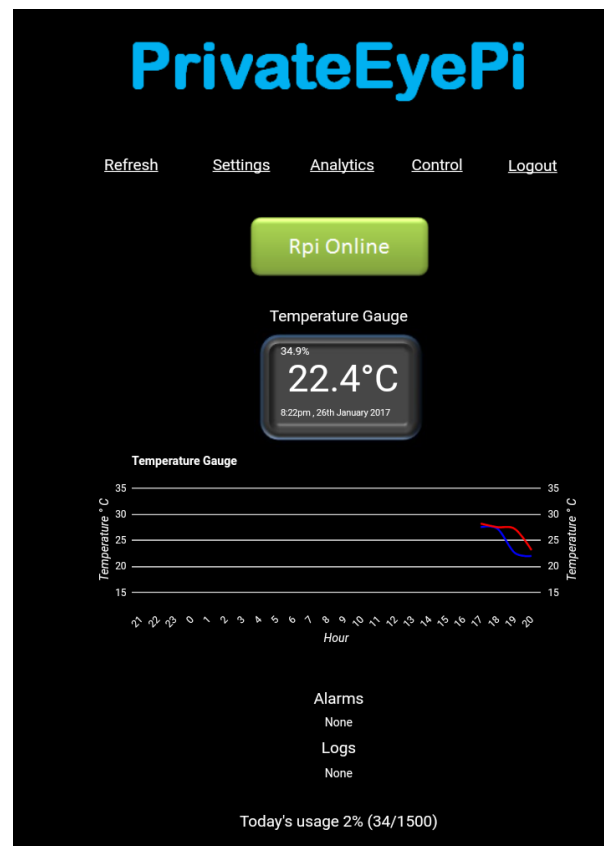
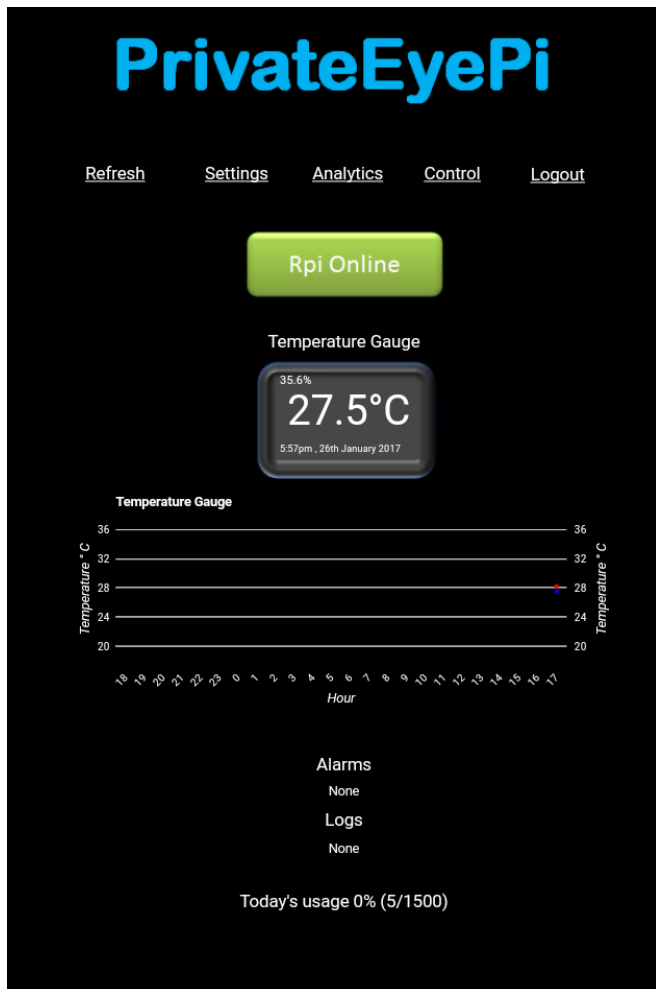

Fig-5: results and graphs

## REFERENCES

- [1] International Journal of Advanced Research(IJAR) in Computer and Communication Engineering-Vol. 5-October 2016` Raspberry Pi Based Weather Monitoring System  
Meetali V. Rasal, Prof. Jaideep G. Rana.
- [2] International Journal for Innovative Research in Science & Technology (IJIRST)-Volume 1-May 2015' The Real Time Temperature Sensing using Raspberry Pi.
- [3] <http://www.projects.privateeyepi.com/home/home-alarm-system-project/temperature-and-humidity>.
- [4] <https://www.python.org>
- [5] Official site of raspberry pi  
<https://www.raspberrypi.org>
- [6] <http://lifehacker.com/the-best-operating-systems-for-your-raspberry-pi-project-1774669829>
- [7] <http://www.instructables.com/id/Raspberry-PI-and-DHT22-temperature-and-humidity-lo/>
- [8] Raspberry Pi Projects Book by Mike Cook and W. Andrew Robinson
- [9] Learning Python with Raspberry Pi Book by Alex Bradbury and Ben Everard
- [10] Lee, CY; Lee, GB. Humidity Sensors: A Review. *Sens. Lett* **2005**, 3, 1-14.
- [11] BeagleBone and Raspberry Pi accessories: Adafruit Industries. <http://www.adafruit.com>

## BIOGRAPHIES



Vatsal D. Shah is pursuing Btech. In the stream of mechanical engineering from Charotar university of science and technology(CHARUSAT).