

# Speed Synchronisation Of Multiple Motors And Variable Flow Controlling Of Motor

Mr. Aditya Dharmadhikari<sup>1</sup>, Mr. Babaso Garale<sup>2</sup>, Prof. Mr. Ankit Chourasia<sup>3</sup>

<sup>1&2</sup>Electrical Department, SKN Sinhgad Institute of Technology and Science, Lonavala, Maharashtra, India

<sup>3</sup>Professor, Electrical Department, SKN Sinhgad Institute of Technology and Science, Lonavala, Maharashtra, India

\*\*\*

**Abstract** - In this venture, another control approach for ongoing pace synchronization of numerous enlistment motors amid speed increasing speed and load changes is produced. The control technique is to settle speed following of every motor while synchronizing its movement with other motors' movements so differential speed blunders among various motors merge to zero.

In industry many procedures required speed synchronization of more than one motors required all the while. Speed control of motor is imperative particularly in the fields including mechanical applications, apply autonomy, material factories, and so on. In all these application motor speed synchronization is animate in transport line driven by different motors. Sudden changes in load cause chasing and oscillatory conduct in DC machine. This conduct can be unsafe to the procedure. There are such a variety of strategies which is utilized for controlling the DC machines. Among all these strategy ace slave synchronization is a broadly utilized method. The ADC is accessible in microcontroller chip which make criticism circle. A driver circuit is utilized to drive the motor. In this strategy, the direction of motor's speed is accomplished by changing the voltage of the motor which is balanced by the obligation cycle of PWM

## 1. INTRODUCTION

There are distinctive sorts of motors utilized as a part of ventures, preparing mills and so forth. The fundamental issue is to keep up the distinctive speed (RPM) of various motors i.e. control over the speed for each motor.

To overcome the problem of control over speed for different motors we designed a single controller which can vary the different motor's speed at a time from one place. It decreased the use of different controllers to control the speed for different motors. In this project we are dealing with speed (RPM) of motor which has a variable water supply. Our aim is to provide a constant flow of water at output side of motor whether the flow of water at input has increased or decreased. Pumping of motor is controlled using motor speed controller, accordingly to the change in flow which in turn increases or decreases the motor speed. There is a facility of relay used to switch off the motor when the water flow goes below the minimum level to prevent from burning/damage.

## 1.1 Need of Speed Synchronisation

The real issues in applying a customary control system in speed controller are the impacts of non-linearity in a DC motor. The non-direct qualities of a dc motor, for example, immersion in erosion could embarrass the execution of customary controller. In material industry, moving of dress ought to be synchronized with the speed of weaving axle to evade harm. Substantial load varieties cause chasing or oscillatory conduct in DC machine.

In the most recent couple of years has made it conceivable to apply cutting edge control innovation to control productive and solid operation of numerous applications, for example, the paper mills, journey, electric vehicles, materials factories, floor mills and mechanical technology. Huge numbers of these operations including electric motors and in this way there is a requirement for practical successful control techniques with advanced control of these motors. In customary procedures motors are synchronized through mechanical transmission framework comprising of a line shaft gears, pullers. So for variable load condition speed control is vital to accomplish a hearty framework. This venture displays the plan and usage of microcontroller based speed control of motors. For PWM era Arduino microcontroller is utilized.

## 2. LITERATURE SURVEY

**[1] "Speed Synchronization of Multiple Motors by Using Microcontrollers"** Gauri R. Shinde<sup>1</sup>, Ashwini T. Deshmukh<sup>2</sup>, Prof. R. V. Katre<sup>3</sup>

In textile industry many processes required speed synchronization of more than one motors involved in the process. Speed control of motor is very important especially in the fields including industrial applications, robotics, textile mills, etc. In all these application motor speed synchronization is invigorate in conveyor belt driven by multiple motors. Sudden changes in load cause hunting and oscillatory behavior in DC machine. This behavior can be harmful to the process. There are so many methods which is used for controlling the DC machines. The synchronization is done by using microcontroller chip which controls the master slave whose speed is followed by the other motors which all have to be synchronized.

[2] "Speed Synchronization of Multiple Bldc motors In Textile & Paper Mills Using Micro Controller" Ankur Shukla<sup>1</sup>, Ankit Kumar<sup>2</sup>, Anil Kumar Rajak<sup>3</sup>, Vivek Kumar Singh<sup>4</sup>, Santhosh S<sup>5</sup>

Multiple motor setup has vast application in industries. The application can be in textile mills, paper mills and robotics. In these all application the synchronization is must between the motors to perform certain task. Speed synchronization is very essential in these all operation to avoid damage to the product. The synchronization is done by using microcontroller chip which controls the master slave whose speed is followed by the other motors which all have to be synchronized.

3.ARCHITECHTURE OF THE SYSTEM

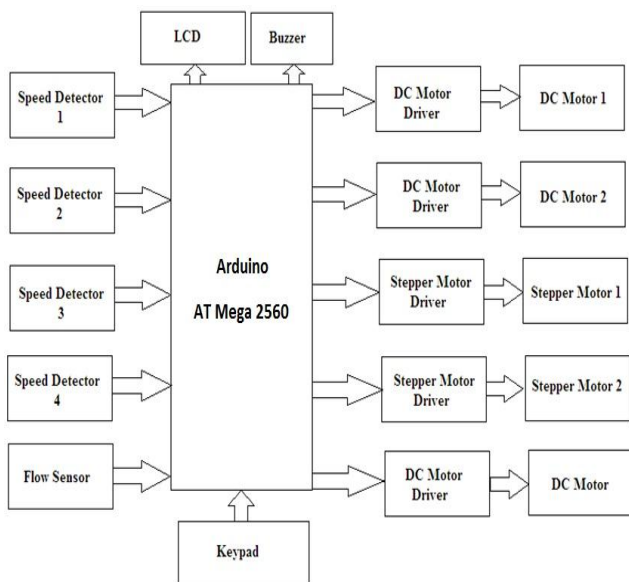

Hardware:

- Speed sensors
- Flow sensors
- Arduino controller
- Keypad
- LCD
- DC motor and Stepper motor Driver
- DC motor and Stepper motor
- Buzzer

3.1. Hall effect Speed sensors

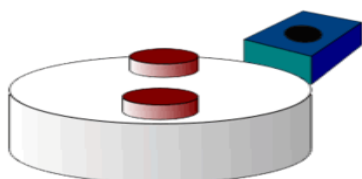

Fig.3.1.Hall Effect Speed sensor

Materials for Hall effect sensors

A Hall Effect sensor is a transducer that shifts its output voltage in light of an magnetic field. Lobby impact sensors are utilized for vicinity exchanging, situating, speed location, and current detecting applications.

Working guideline

At the point when a light emission particles goes through an magnetic field, strengths follow up on the particles and the bar is diverted from a straight way. The stream of electrons through a conductor is known as a light emission transporters. At the point when a conductor is put in an magnetic field opposite to the heading of the electrons, they will be avoided from a straight way. As an outcome, one plane of the conductor will turn out to be adversely charged and the inverse side will turn out to be emphatically charged. The voltage between these planes is called Hall voltage.

The key factor determining sensitivity of Hall effect sensors is high electron mobility. As a result, the following materials are especially suitable for Hall effect sensors:

- gallium arsenide (GaAs)
- indium arsenide (InAs)
- indium phosphide (InP)
- indium antimonide (InSb)
- graphene

Advantages

A Hall effect sensor may work as an electronic switch.

- Such a switch costs not exactly a mechanical switch and is a great deal more solid.
- It can be worked up to 100 kHz.
- It does not experience the ill effects of contact bob on the grounds that a strong state switch with hysteresis is utilized as opposed to a mechanical contact.
- It won't be influenced by natural contaminants since the sensor is in a fixed bundle. In this way, it can be utilized under extreme conditions.

On account of direct sensor (for the attractive field quality estimations), a Lobby effect sensor:

- can measure an extensive variety of attractive fields
- is accessible that can quantify either North or South shaft attractive fields

Disadvantages

Hall effect sensors give much lower measuring precision than fluxgate magnetometers or magneto resistance-based

sensors. Additionally, Hall effect sensors float altogether, requiring compensation.

M12DC inductive Proximity switch/sensor 2mm/4mm Flush / nonflush

### 3.2 Hall effect Flow sensor

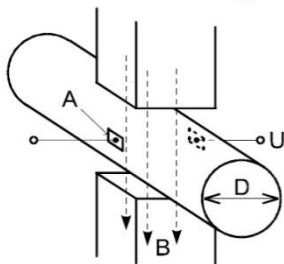

Fig.3.2.Hall Effect flow sensor

This sensor sits in line with your water line and contains a pinwheel sensor to measure how much liquid has moved through it. There's an integrated magnetic hall effect sensor that outputs an electrical pulse with every revolution. The hall effect sensor is sealed from the water pipe and allows the sensor to stay safe and dry.

The pulse signal is a simple square wave so its quite easy to log and convert into liters per minute using the following formula.

$$\text{Pulse frequency (Hz) / 7.5 = flow rate in L/min.}$$

#### Working principle

When a beam of charged particles passes through a magnetic field, forces act on the particles and the beam is deflected from a straight path. The flow of electrons through a conductor is known as a beam of charged carriers. When a conductor is placed in a magnetic field perpendicular to the direction of the electrons, they will be deflected from a straight path. As a consequence, one plane of the conductor will become negatively charged and the opposite side will become positively charged. The voltage between these planes is called Hall voltage.

### 3.3 CONTROLLER (Arduino Mega 2560)

The Arduino Mega 2560 is a microcontroller board in light of the ATmega2560. It has 54 digital i/o pins (of which 14 can be utilized as PWM outputs), 16 simple data sources, 4 UARTs (equipment serial ports), a 16 MHz crystal oscillator, an ICSP header, a power jack, a USB connection , and a reset key. It contains everything expected to support the microcontroller; just associate it to a PC with a USB link or power it with an AC to DC connector or battery to start. The Mega is perfect with most shields designed for the Arduino Duemilanove or Diecimila.



Fig.3.3.Arduino controller

#### Features

Parameter Name	Value
Microcontroller	ATmega2560
Operating Voltage	5V
Input (recommended) Voltage	7-12V
Input Voltage (limits)	6-20V
Digital I/O Pins	54 (of which 14 provide PWM output)
Analog Input Pins	16
DC Current per I/O Pin	40 mA
DC Current for 3.3V Pin	50 mA
Flash Memory	256 KB of which 8 KB used by bootloader
SRAM	8 KB
EEPROM	4 KB
Clock Speed	16 MHz

### 3.4 LCD(2x16)

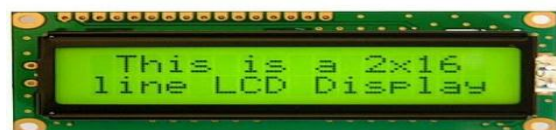

Fig.3.4.LDC Display

LCD (Liquid Crystal Display) screen is an electronic display module and locate an extensive variety of uses. A 16x2 LCD display is exceptionally fundamental module and is regularly utilized as a part of different gadgets and circuits. These modules are supported more than seven parts and other multi divide LEDs. The reasons being: LCDs are economic; effectively programmable; have no constraint of displaying unique and even custom characters (not at all like in seven fragments), animation and so on.

A 16x2 LCD implies it can display 16 characters for every line and there are 2 such lines. In this LCD every character is displayed in 5x7 pixel framework. This LCD has two registers, to be specific, Command and Data.

The command register stores the charge guidelines given to the LCD. A command is a guideline given to LCD to do a predefined undertaking like instating it, clearing its screen, setting the cursor position, controlling presentation and so on.

### 3.5 DC motor -High Torque Mini 12V DC Gear Motor, 200 rpm

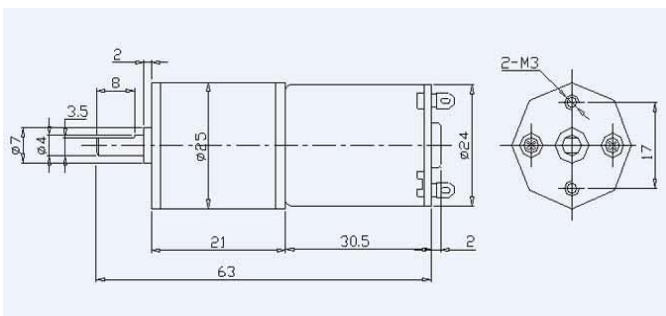

Fig.3.5.DC motor

#### Working Principle-

The principle of **working** of a **DC motor** is that "whenever a current carrying conductor is placed in a magnetic field, it experiences a mechanical force". The direction of this force is given by Fleming's left hand rule and it's magnitude is given by  $F = BIL\sin\theta$

### 3.6 Stepper motor-

stepper motor is an electro mechanical device which changes over electrical pulses into discrete mechanical output. The pole or shaft of a stepper motor turns in discrete step increases when electrical order pulses are connected to it in the best proper sequence. The motors rotation has a few direct connections to these applied input pulses. The speed of the motor shafts rotation is specifically identified with the frequency of pulses and the length of rotation is directly identified with the quantity of input pulses send. The arrangement of the applied pulses is directly related to the direction of motor shafts rotation.

#### Advantages

1. The rotation angle of the motor is proportional to the input pulse.
2. The motor has full torque at standstill (if the windings are energized)
3. Precise positioning and repeatability of movement since good stepper motors have an accuracy of 3 – 5% of a step and this error is non cumulative from one step to the next.
4. Excellent response to starting/stopping/reversing.

#### Disadvantages

1. Resonances can occur if not properly controlled.
2. Not easy to operate at extremely high speeds.

### 3.7 DC and STEPPER motor driver (L293D)

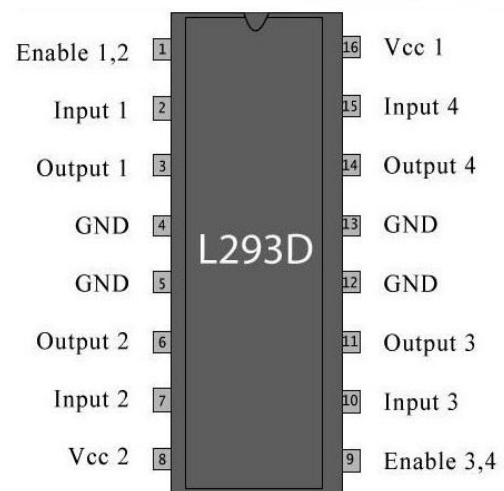

Fig.3.7.DC & Stepper Motor driver(L293D)

The L293 is designed to give bidirectional drive current of up to 1 Amp at voltages from 4.5 Volt to 36 Volt. The L293D and L293 gadgets are quadruple high momentum half-H drivers. The L293D is designed to give bidirectional drive current of up to 600-mAmp at voltages from 4.5 Volt to 36 Volt. Both devices are intended to drive inductive loads, for example, solenoids, relays, DC and bipolar stepper motor, and additionally other high-current/high-voltage loads in positive supply applications.

### 3.8 Buzzer

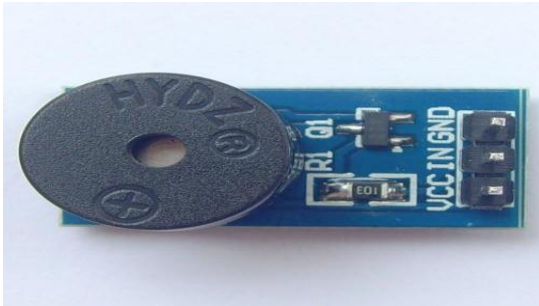

Fig.3.8.Buzzer

#### General Description:

Buzzer is an integrated structure of electronic transducers, A buzzer or beeper is a sound signaling device, which might be mechanical, electromechanical, or piezoelectric. Normal use of buzzers and beepers incorporate alert device, timer and confirmation of user input, for example, a mouse click or keystroke.

Buzzer is a coordinated structure of electronic transducer.

#### 4. CONCLUSION

The problem in process industry is to achieve speed synchronization of multiple motors ,which can be resolved by using single microcontroller (Arduino) instead of separate microcontrollers. In older days single controller was used for the controlling purpose, which is the quite difficult task for the synchronize speed of motors for the process.

We are using the arduino controller to overcome this problem. Single controller can achieve desired speed synchronization and control over all equipment's and sensors used in industry. Use of single controller is feasible that use multiple controllers for multiple motors. Thus this technique is useful and economic for controlling purpose. Also we have more control areas where we are using same controller i.e. we use this controller for flow monitoring in pipes, temperature control of furnace and process, light intensity control and much more areas which are controlled by the arduino

#### 5. REFERECES

- [1] "Speed Synchronization of Multiple Motors by Using Microcontrollers". Gauri R. Shinde<sup>1</sup>, Ashwini T. Deshmukh<sup>2</sup>, Prof. R. V. Katre<sup>3</sup>
- [2] "Speed Synchronization of Multiple BLDC motors In Textile & Paper Mills Using Micro Controller". Ankur Shukla<sup>1</sup>, Ankit Kumar<sup>2</sup>, Anil Kumar Rajak<sup>3</sup>, Vivek Kumar Singh<sup>4</sup>, Santhosh S<sup>5</sup>
- [3] Wenxin Liu, Li Liu, Il-Yop Chung, David A. Cartes, Wei Zhang "Modelling and detecting the stator winding fault of permanent magnet synchronous motors" Simulation Modelling Practice and Theory 27 (2012) 1–16.
- [4] Mohamed S. Zaky "A self-tuning PI controller for the speed control of electrical motor drives ", Electric Power Systems Research 119 (2015) 293–303
- [5] F. Beltran-Carbajala, A. Valderrabano-Gonzalez, J.C. Rosas-Carob, A. Favela-Contreras Universidad "An asymptotic differentiation approach of signals in velocity tracking control of DC motors" Electric Power Systems Research 122 (2015) 218–223
- [6]. MOTOR SELECTION for BELT-CONVEYOR DRIVES by Garry E. Paulson, P. Eng.
- [7]. Unique Conveyor Problems and Solutions :- Fenner Dunlop