

# Re-Designing the elements of manually operated paper recycling machine for longer life and improved conditions

Ambati Dheeraj Goud<sup>1</sup>, Bharath Turlapaty<sup>2</sup>

<sup>1</sup>M.Tech Student, Department of Mechanical Engineering, Aurora Technological and Research Institute Hyderabad, India. Email-Id:dheerajgoud.777@gmail.com

<sup>2</sup>Design Engineer, Cyient, Hyderabad, India. Email-Id:turlapaty.bharath@gmail.com

\*\*\*

**Abstract** – Paper recycling has a prime importance as the whole world expresses its concerns for the deforestation and increased pollution on the earth. Securing natural resources and improvement of the green count on the earth for the next generation has a critical reception in the current world. Recycling is a codicil for the production of new paper. This process actually helps in reduction of deforestation which would have a direct impact on preservation of the natural resources on earth clouting the adverse affects of pollution. The innovation targeting the recycling of the paper, portable manually operated recycling machine is a highly appreciable step ahead promoting the decreased conservation of the earth's resources. The byproducts in the process of paper recycling also could be used for various other purposes and in industries as raw material. Acknowledging the existing idea of the portable manually operated paper recycling machine, the objective of our project is to improve the reliability, sustainability and the life of the paper recycling machine by improving the design elements of the machine performing structural analysis on the various elements and identifying the element on whose change in design could be implemented for the improvement in the life of the machine.

**Key Words:** Paper recycling, Preservation of natural resources, Structural Analysis, Improved design, longer life

## 1. INTRODUCTION

The paper recycling machine mainly consists of the pulp feeding system, pulp transferring system, calendaring system and driving mechanism whose functions are as the titles of the systems convey. The major setup of the machine is manufactured with mild steel due to its lower cost, higher weld ability, better toughness, higher ductility and malleability. The line diagram of the machine layout (motor, gear box, belt and pulley excluded) is as follows:

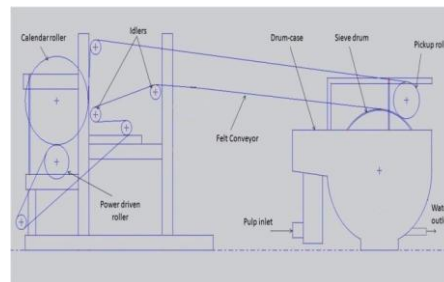

Fig -1: Layout of paper recycling machine

## 2. METHODOLOGY

The pulp feeding system being the most crucial component in the paper recycling machine and which is at a higher risk considering the stress acting on the machine, the pulp feeding system has been chosen as the area of interest to perform the analysis on. The methodology for the whole process has been defined as follows:

- Design Calculations of the various parts of the pulp feeding system would be performed with the data available from the literature.
- With evolved dimensions, the individual parts of the system and a 3D assembly would be modeled in CAD software.
- The 3D models would be imported into analysis tool.
- Detailed structural analysis would be performed on the individual components of the pulp feeding system.
- The stresses induced in these components obtained from the analysis program are to be plotted and documented.
- A crucial component affecting the stress and deflection would be chosen to intend a change in the design and trials have been made continuously with a variation in the dimensions.

- A detailed analysis would be performed on the component again that had been modified to achieve the requirement of increased factor of safety.
- Increase in life would be achieved with an improvement in the factor of safety.

### 3. PROCESS OF OPTIMIZATION

The components of the pulp feeding system have been modeled and an assembly of the pulp feeding system has been created in UG NX. The 3D assembly of the pulp feeding system is as follows:

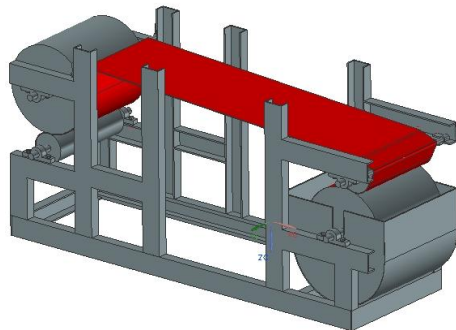

**Fig -2:** Assembly of the pulp feeding system

The individual components have been imported into ANSYS and a detailed structural analysis has been performed and the values are as follows:

**Table -1:** Stresses induced in various components

Stresses induced in various components of the pulp feeding system (In MPa)				
Component	Stress in X	Stress in Y	Stress in Z	Von Mises Stress
Sieve Drum Case	29.76	45.18	54.85	243.93
Sieve Drum	4.48	1.33	4.44	4.05
Big Calendar Roller	0.71	0.30	0.77	0.96
Small Calendar Roler	0.22	0.26	0.20	0.26

Evaluating the obtained results and analyzing the induced stresses, it had been observed that the sieve drum case is the component that needs an improvement in the design to increase the life and quality of the product. With the existing dimensions, the

sieve drum case has an excessive stress at the corners which could lead to buckling. Also the mounting point of the sieve drum case is weaker which could lead to increased chances of failure of the machine. We have implemented an increase in the thickness of the walls of the sieve drum case from 2mm to 3 mm and haven't observed the desirable results. Also, analysis has been performed considerably increasing the thickness of the walls to 4mm and 4.5 mm. But the desired results haven't been obtained. We have later performed an analysis by increasing the thickness value to 5mm. We have obtained an optimum stress value with a considerable increase in the factor of safety which was be a desired output expected.

The comparative data of the existing and proposed sieve drum cases are as follows:

**Table -2:** Comparison of existing and modified sieve drum cases

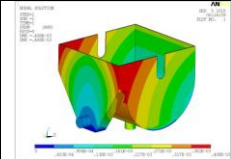
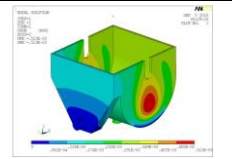
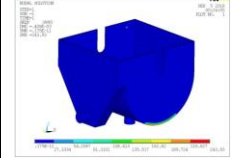
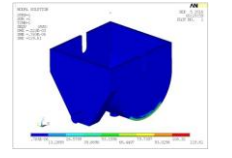
Comparison of existing and modified sieve drum cases		
Parameter	Existing Sieve Drum Case	Modified Sieve Drum Case
Thickness of walls	2mm	5mm
Yield Strength	240 MPa	240 MPa
Stress in X dir	29.76 MPa	8.74 MPa
Stress in Y dir	45.18 MPa	14.4 MPa
Stress in Z dir	54.85 MPa	17.16 Mpa
Von Mises Stress	243.93 MPa	119.61 MPa
Max Displacement Distribution		
Von Mises Stress distribution		
Factor of Safety	0.984	2.06

### 3. CONCLUSIONS

The Von Mises Stress has been reduced from 243.9 MPa to 119.61 MPa and the yield strength constrained to 240 MPa which is quite larger than the working stress of the proposed sieve drum case. Hence according to the Maximum Yield Stress Theory, the Von Mises stress being lower than the yield strength of the material is a desirable characteristic in a design. From results of static analysis, both Sieve drum and Calendar rollers have stress values within limits. But in case of Sieve drum case, the Von misses stress is proved to be beyond the limit of yield strength of material used. So, modifications were done to the design of Sieve drum case. From results, the modified sieve drum case has Von Mises stress within limits of the yield strength of material used. So, the proposed model of the sieve drum case has been proved to have better working conditions in comparison to existing sieve drum case with an improvement in Factor of Safety from 0.984 to 2.06.

### REFERENCES

- [1] Vrushabh R. Rathod, Saurabh R. Rathod, Nitin H. Wankhede " Design of Manually Operated Portable Paper Recycling Machine"
- [2] M. A. OLUTOYE "Design of a Manually Operated Paper-Recycling Machine" ISSN 1583-1078, Issue 7, July-December 2005 p. 49-54.
- [3] Prof. Kusekar S.K, Morajkar C.E, Kashid S.N, Hipparkar K.S, Deshpande V.S " Design & Development of Plastic Recycling Machine by Using FEA" e-ISSN: 2395-0056 Volume: 02 Issue: 02,May-2015.
- [4] Scott M. Kaufman "Analysis of Technology and Infrastructure of the Paper Recycling Industry in New York City". (Submitted in partial fulfillment of requirements for M.S. thesis in Earth Resources Engineering)
- [5] Mahendra R.Doshi and Jeffrey M.Dyer "Paper recycling challenge (Volume-ii)". ISBN-13: 978-0965744706, ISBN-10: 0965744701
- [6] Ochor Spencer Chidi "design and construction of waste paper recycling plant" ISSN: 2304-9693, Vol. 4 No. 6 August, 2015"
- [7] James Ian Mathews "Home Paper Recycling Machine". (In Partial Fulfillment of the Requirements for the Degree)
- [8] Prof. Bhojraj N. Kale, Aditya Guhe, Ghanshyam S. Bodkhe, Vishal Kuril, Pranav Waghmare "Waste Paper Recycling - An Approach to Sustainability" IJSART - Volume 2 Issue 4-april 2016 ISSN [ONLINE]: 2395-1052
- [9] Aperebo E.M, Onilude M.A and Komolafe O.O "Design of Waste Paper Recycling Machines", (ISSN: 2141-7016),2016