

Automatic Power Factor Controller(APFC) with GSM

Prof. S.M.Chaudhari¹, Pooja Beek², Varsha Padalkar³, Rupali Barge⁴, Aishwarya Bhavsar⁵

¹ HOD of Electrical Engineering, AISSMS' IOIT, Maharashtra, India

^{2,3,4,5} Student (B.E.), Dept. of Electrical Engineering, AISSMS' IOIT, Maharashtra, India

Abstract - In the present technological revolution power is very precious. So we need to find out the causes of power loss and improve the power system. Due to industrialization the use of inductive load increases and hence power system loses its efficiency. So we need to improve the power factor with a suitable method. In case of fixed loads, power factor correction can be done manually by switching of capacitors, but in case of rapidly varying loads it becomes difficult to maintain a high power factor by switching of capacitors. This drawback is overcome by using an APFC panel. In this thesis we describe the design and development of microcontroller based automatic power factor correction along with GSM. When required power factor is not attained message is sent to the user via GSM.

Key Words: Power factor, Capacitor banks, Power factor correction, PIC microcontroller, GSM module

1. INTRODUCTION

Power factor is the ratio of true power to apparent power. Power factor is a measure of how effectively electrical power is used to perform an useful work. The ideal power factor is unity. If the power factor is less than 1 it means that excess power is required to perform actual work.

Advantages of PF improvement:

- Reduction of I²R losses in transformer and distribution equipment.
- Efficiency increases due to reduction of power consumption.
- Reduction of electricity bills.
- Extra KVA available from same existing supply.

1.1 Methods Of Power Factor Correction:

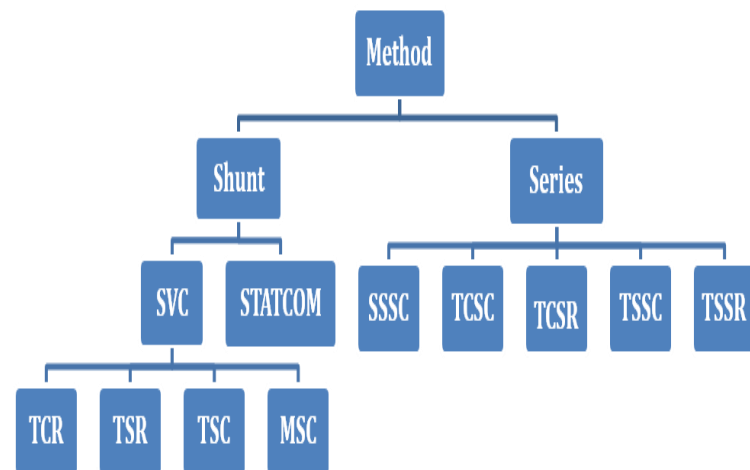

Fig 1: Methods Of Power Factor Correction

Focused Method:

APFC Method :

A. Main components :

Main components used in this scheme for automatic power factor correction using microcontroller includes following components.

1. Auxiliary power Supply:
 - Transformer
 - Bridge rectifier
 - Voltage regulator IC 7805
2. Microcontroller (AT-mega328p)
3. LCD Display
4. Capacitor Bank
5. Potential transformer & current transformer

B. BLOCK DIAGRAM:

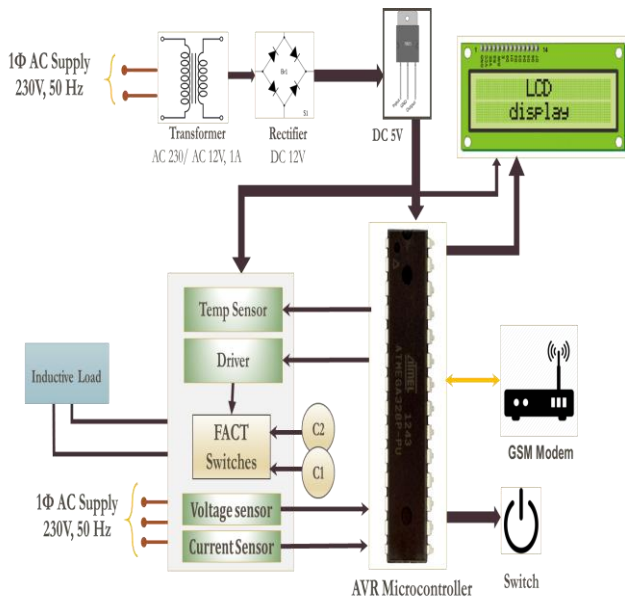

Fig2: Block Diagram Of APFC System

Fig2 shows the block diagram of APFC system.

The input to the circuit is given from the regulated power supply. The AC input i.e. 230V from the mains is step down by transformer to 12V and is fed to the rectifier. The output obtained from the rectifier is a pulsating DC voltage. So in order to get a pure dc voltage, the output voltage from the rectifier is fed to a filter to remove any AC components present even after rectification. The supplied voltage and current signals taken through potential transformer and current transformer. The two sinusoidal waveforms are given to ADC pins of microcontroller and active and apparent power is calculated and thus power factor is calculated. It controls the capacitor bank as required to compensate for leading or lagging power factor.

If required compensation is not obtained after adding the capacitors, an alert is sent to the users mobile via GSM.

1.2 Case Study of Inductive Load

Given:- 400V,50Hz,3ph,100HP(74.6KW)
0.75p.f lag, efficiency 93%

Solution:-

Original p.f: $\cos\phi_1=0.75$ lag,
Desired pf : $\cos\phi_2 =0.95$ lag
Input P = 80KW

Leading kVAR taken by capacitor bank
= $P(\tan \phi_1-\tan \phi_2)$
= 44.25 kVAR

Phase current of capacitor ,

$$I_{cp} = 2\pi f C V_{ph}$$

$$= 125600 C \text{ Amp}$$

$$kVAR/phase = \frac{V_{ph} I_{cp}}{1000}$$

$$= 50240 C$$

$$C = \frac{kVAR}{kVAR/ph}$$

$$= 293.4 \mu f$$

1.3 SIMULATION AND OBSERVATIONS

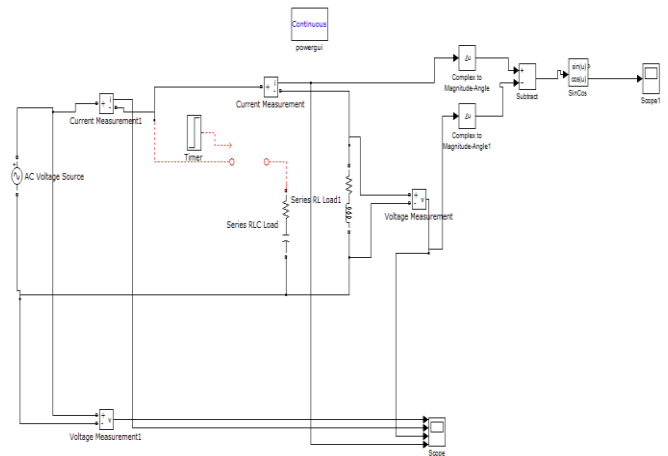
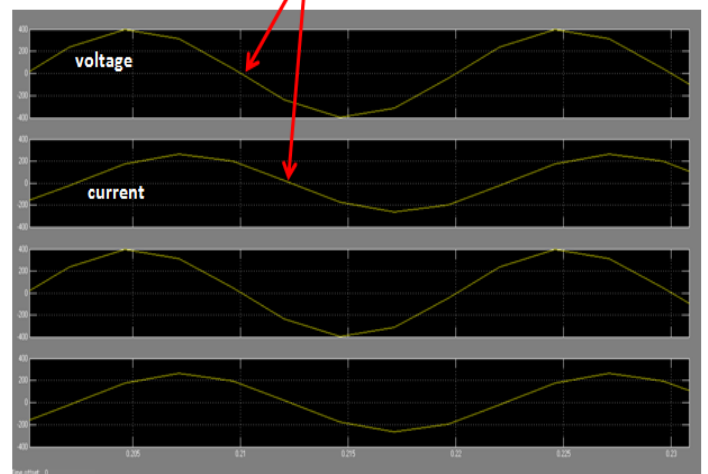

Fig3: Simulation of Inductive Load Without Capacitor Bank

**SIMULATION RESULT OF SYSTEM:
(WITHOUT CAPACITOR BANK)**

p.f=0.75 hence $\phi = \cos^{-1}(0.75)=41.40^\circ$ (pf angle)



Circuit diagram of system (with capacitor bank)

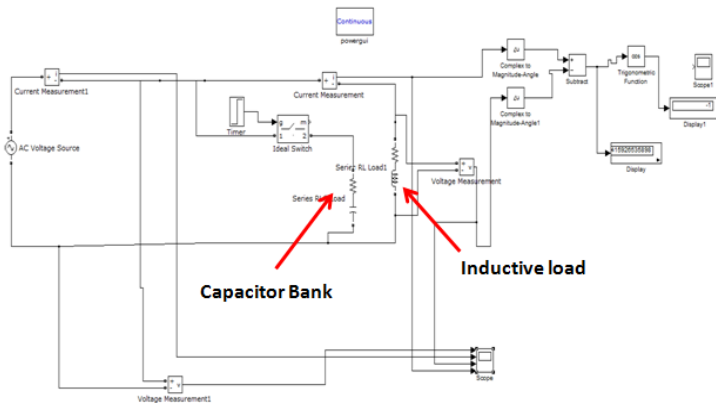

- National Institute of Technology ,Rourkela Automatic Power Factor Correction By Microcontroller 8051
- Power Factor Compensation ABB Capacitors

Fig4: Simulation of Inductive Load With Capacitor Bank

SIMULATION RESULT OF SYSTEM (WITH CAPACITOR BANK)

Desired $p.f=0.95$ hence $\phi = \cos^{-1}(0.95)=18.19^\circ$ (p.f angle)

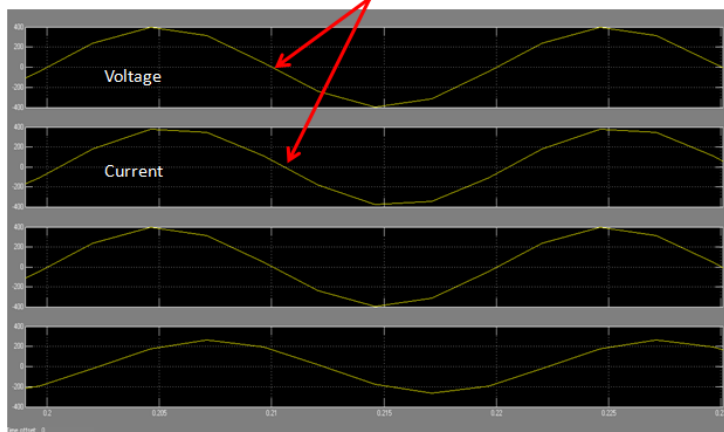

2. Conclusion:

This thesis work is an attempt to design and implement the APFC system using PIC microcontroller. PIC continuously monitors the power factor and then according to the lagging and leading power factor it takes the control action. This thesis also gives the further modification of GSM system. When required compensation is not achieved, message is sent to the user via GSM and corrective action is taken accordingly.

3. References:

Books:-

- Reactive Power Management by **D.M.Tagare**
- Principles of Power System by **V.K.Mehta**

Papers:-

- International Journal of Engineering and Innovative Technology (IJEIT) Volume 3, Issue 4, October 2013 Power Factor Correction Using PIC Microcontroller