

# EVALUATION OF METAL MATRIX COMPOSITION FOR STEERING KNUCKLE USING MEDIUM LEADED BRASS UNS C34000

M.Ramesh<sup>1</sup>, J.Kavikko<sup>2</sup>,A.Muhammed Shiek Madhar<sup>3</sup>,M.Raghul<sup>4</sup>

<sup>1</sup>.Assisant Professor, Department of Mechanical Engineering, Sri Ramakrishna Engineering College

<sup>2</sup>.Final Year Student, Department of Mechanical Engineering, Sri Ramakrishna Engineering College

<sup>3</sup>.Final Year Student, Department of Mechanical Engineering, Sri Ramakrishna Engineering College

<sup>4</sup>.Final Year Student, Department of Mechanical Engineering, Sri Ramakrishna Engineering College

\*\*\*

## ABSTRACT:

To improve the life time of the steering knuckle, we have improved its yield strength of the steering knuckle, for that we are going for metal matrix process to improve the life time of the material. We know that Brass is the abundant, material available with good properties and low cost, and by taking the Brass as matrix component we have made a suitable change to the steering knuckle material composition with medium leaded brass of the type UNS C34000. The yield strength of brass alloy composition is 103MPa by adding the composite alloys and heat treatment process the yield strength has been increased to 414MPa

**Keywords:** steering knuckle, stress, factor of safety, Brass, matrix composition

## INTRODUCTION:

Steering knuckle is that part which contains the wheel hub or spindle, and attaches to the suspension components. Steering knuckle works on various load condition in automobile vehicles, the knuckle should withstand the various load conditions without any failure its service life time [1]. The load acting on the steering knuckle varies based on the type of the vehicle and the weight of the vehicle. This system also means in keeping the vehicle stable on of irregularities in movement in the surface over which the vehicle is travelling. The failure in this will result in the loss of working of the model [2]. The wheel spindle in the centre is connected to steering

parts and the wheel hub assembly from the other. Steering knuckle should withstand high fatigue rate. During the process of cycling and variation of speed.

## MATERIAL SELECTION:

Martial selection is based on the high yield strength, elastic modulus [11], optimum in manufacturing ways. The matrix component of steering knuckle majorly consist of Aluminium. Aluminium and brass alloy were of less cost compared to the other alloys.

In the aluminium composition and brass composition[18] the best one is selected using their property criteria and so we can choose the aluminium [10] and brass as matrix component. The brass has composition of

high yield strength compared to aluminium composition, the yield strength of aluminium is improved by doing the hot working and cold working process on the state of working like aniline and hardness types with T6,T7 so that we can improve strength[13], but brass has comparatively high yield strength compared to the aluminium composite material, but the bras composite material has been chosen as medium leaded brass UNS C34000 [17] have high yield strength of 103to 414MPa

**Table 1 Property**

Material	Medium leaded brass UNS C34000
Density	8.47g/cm <sup>3</sup>
Elastic modulus	117 GPa
Tensile strength	324-607MPa
Yield strength	103-414 MPa

**MODELLING**

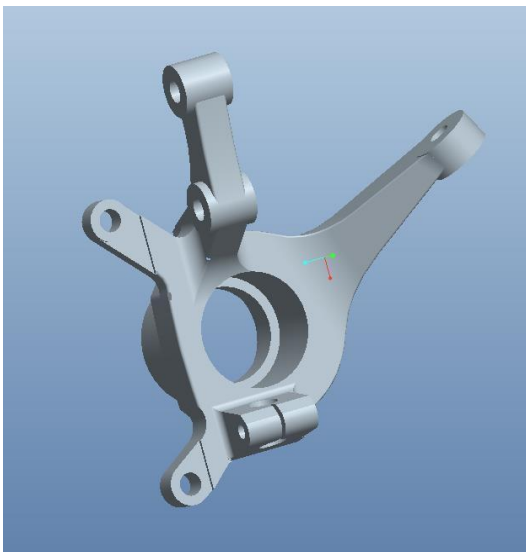

**Fig 1 Creo Model**

The drawing has been carried out with the help of creo 2.0 software where the required geometry is obtained. The modelled diagram is then imported from the cero software to the analysis software. The analysis software used here is ANSYS 15.0 WORKBENCH [14]. This software helps to find the required solution for the given material. The mesh model is then checked for its static condition [1]. After completing mesh, the loads are specified to check the resisting condition of the material. For brass the load applied is 4500N [12] it gives the stress analysis and safety factor. The loads are generally applied all around the steering knuckle but here it is applied on the steering arm as it is in motion with the spindle. The spindle moves along with the wheel. Next load is applied in struct mount [6] where the load acts in downward direction. Here the arm is not fixed it has lot of constraints.

**MESH MODEL:**

The mesh model depicts the load acting on the material in the direction in the brass area. The trace formation [10] depicts the number of nodes acting on it. The number of nodes acting is 977900. The total elements from mesh would be 675052. The meshing is carried out from the IGES file. The whole model consists of steering arm [11], suspension arm and break calliper. The meshing has been done using ANSYS 15.0 WORKBENCH software as it has

easy access to clearly identify the areas. The material property plays a huge impact in it. The Element should be of good resistance to load applied. Geometry clean-up was performed prior to [7] meshing of model. The meshed model could show as the accurate possible load applying condition. The steering knuckle imported from IGES format has been put under all required or circumstantial loading condition through meshing [15]. This helps in identifying at fillet position the accuracy and its level of occurrence.

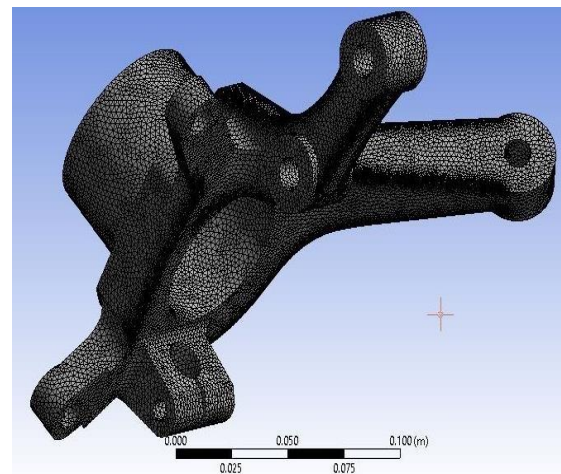

**Fig 2 Mesh Model**

**Table 2 Mesh Specifications**

Type	Medium Triace
Nodes	977900
Elements	675052

**LOAD ANALYSIS:**

The load analysis is a part where the load applied are subjected. The major load is applied at the steering arm as it has the weight acting [4] on it because the steering load and our load acts on it. from steering arm the load is sent to the tyres where it goes with the same load applied or the load gets reduced or increased will all depend upon the calculations yield strength [8] and tensile strength corresponding to it. The bending stress along with torque [5] is considered into main account for the load acting on the arm to the wheels

[16]. The next level of load gets acted on the suspension arms i.e., struct mount and lower ball joint here the load results give us a view about its suspension strength to withstand the force exerted on it. von mises stresses [3] are considered to make a fatigue level of load. There could be no constraints because the load could be acted at all points without any loss in strength. The loads at the struct mount will make the suspension of the wheels not to get damaged as it has a tolerance level of how much it could suppress.

The above figure shows the analysis carried out using ANSYS workbench. It is carried out using static analysis type which will be more suited for it. The load acting points would be in the range of sustainable up to 4500N where the safety of factor is above 1 so the material could be suitable to sustain load. The stress from this load will be maximum at the spindle rotation where a lot of stress occurs and it could be minimum in the back area of the break calliper region.

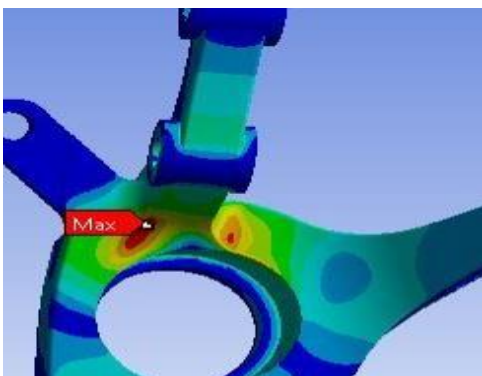

**Fig 3 Maximum Stress**

The above figure shows the maximum stress [9] acting on a steering arm which is used to control the whole movement of the automobile. Considering the factor of safety of the metal matrix component is greater than 1 so that the design is

safe. But the real fact has to be the resistance of the automobile part to withstand all the external forces acting on it. The effect of suspension arm makes the maximum stress acting on it. The load acting depends on three main parameters i.e., braking, accelerating, cornering. And so general load acting has been considered

**FACTOR OF SAFETY**

Brass UNS C34000 material has a good reliability with the factor of safety around 2.3 which is obtained from our analysis the figure has been shown up to gain a clear view. The factor of safety [11] for any component with the required material should be above 1 for the safe model. Here our metal matrix composition with a material of brass has a safety factor of 2.3 which is greater than 1 so the chosen composition could be safe for working.

**RESULT AND DISCUSSION**

The creo model has been taken as the optimized design dimension and model has been created using the creo 2.0 software, the created part model has been used as input for the analysis software.

The brass UNS C34000 brass alloy composition has been taken by considering the high elastic modulus, tensile strength and yield strength

The brass alloy is chosen for matrix component under the consideration of less weight, good properties in composition

Before using the brass alloy composition the metal matrix has been done using aluminium composition

Factor of safety is 2.3 for brass alloy composition is higher compared to the aluminium composition

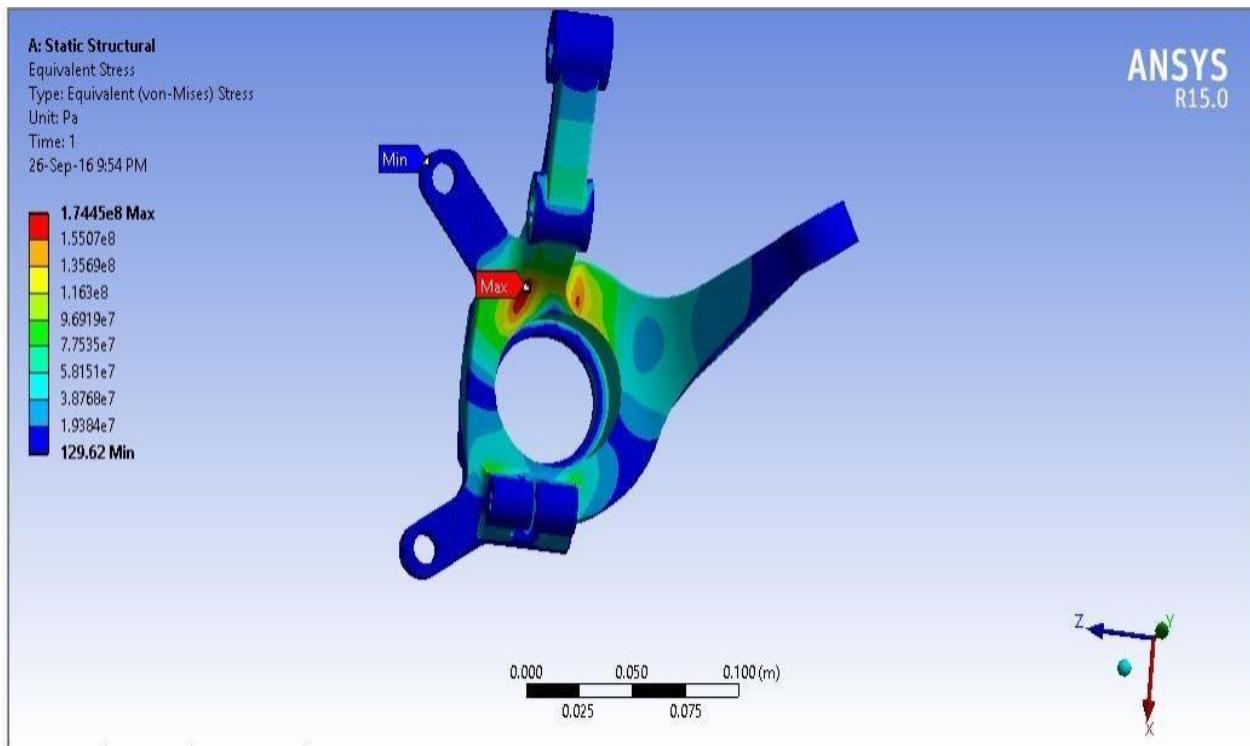

Fig 4 Analysis For Stress

### SAFE DESIGN

#### Front View

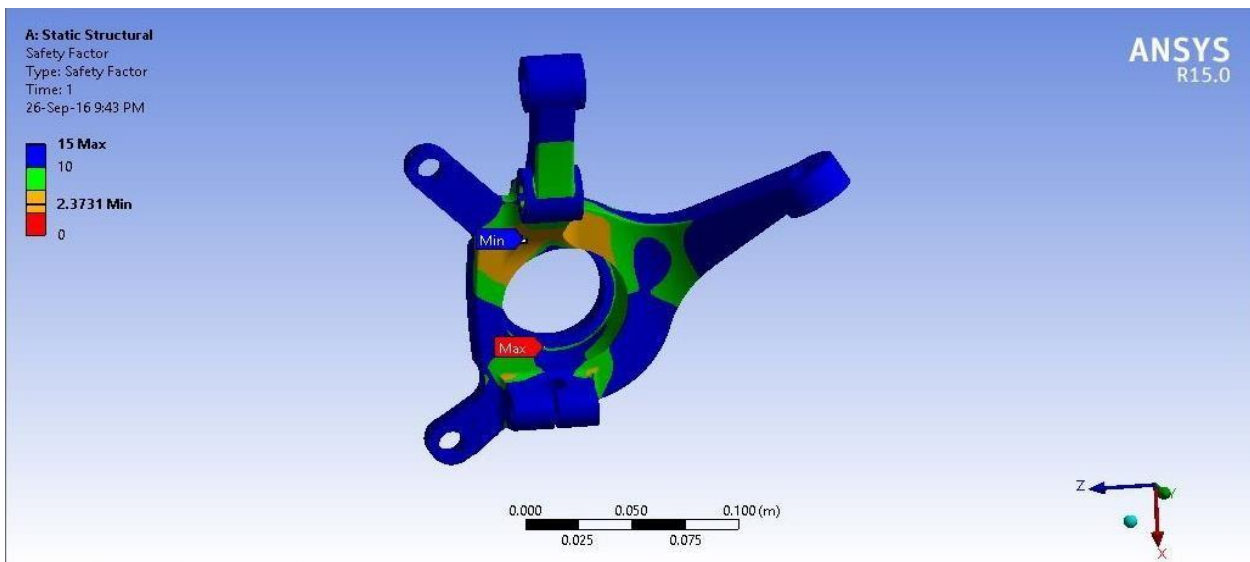
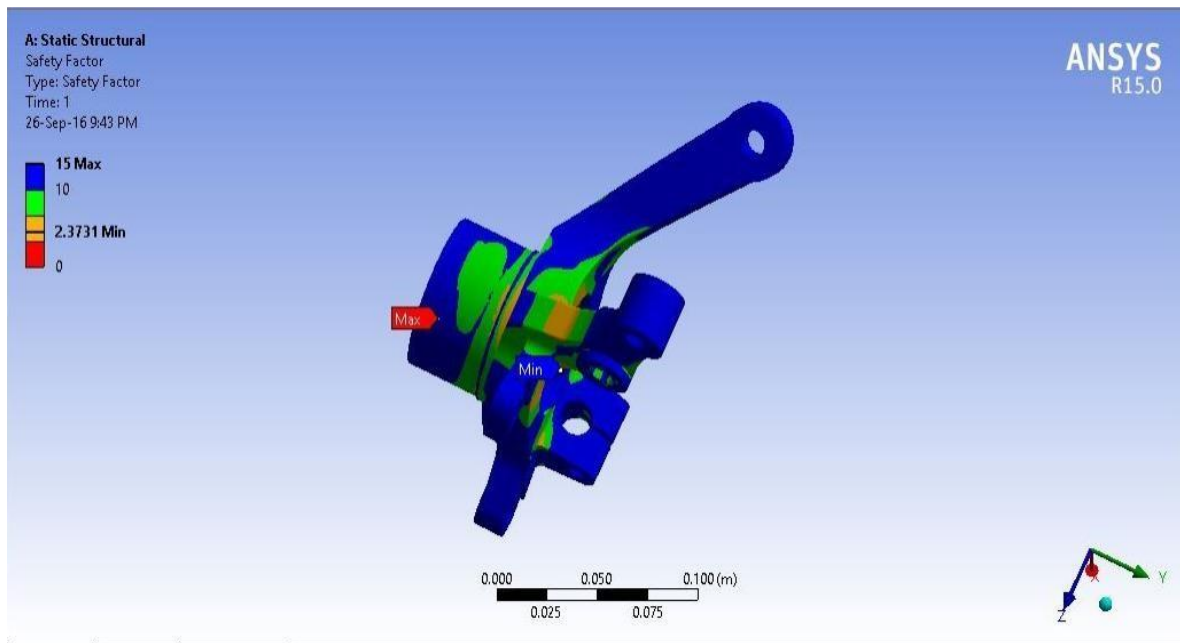

Fig 5 Analysis For Load

#### Side View



**Fig 6 Analysis For Load**

**REFERENCES:**

- 1.Evaluation Of Fatigue Life Reliability Of Steering Knuckle Using Pearson Parametric Distribution Model By E.A.Azrulhisham, Y.M. Asri,A.W.Dzuraidah,N.M.Nik Abdullah,A.Shahrum And C.H.Che Hasan .
- 2.Design And Analysis Of Steering Knuckle Component By Sanjay Yadav,Ravi Kumar Mishra,Varishansari And Shyam Bihari Lal .
- 3.Static Analysis Of Steering Knuckle And Its Shape Optimization By Mahesh P.Sharma,Dinesh S Mevawala, Harsh Joshi,Devandra A.Patel .
- 4.Structural Analysis Of Steering Knuckle For Weight Reduction By Purushottam Dumbre, A.K.Mishra ,V.S. Aher .
- 5.Satigue Life Analysis And Optimization Of A Passenger Car Steering Knuckle Under Operating Conditions By V. Sivananth And S.Vijayarangan .

- 6.Static Analysis And Topology Optimization Of Steering Knuckle By Using Finite Element Method By R.Prem Raj And K.Palpandi .
- 7.Design And Analysis Of Suspension And Steering Components Of F1 Prototype By Tushar Joshi And Vaibhav Joshi .
- 8.Fea & Optimization Of Steering Knuckle Of Atv By Ameya Bhushari, Aditya Chavan, And Sushrut Karmarkar.
- 9.Structural Analysis Of Steering Knuckle For Weight Reduction By Purushottam Dumbre,Profa.K.Mishra,V.S.Aher,Swapnil , Kulkarni .
- 10.Effect Of Loading On Various Point Of Steering Knuckle By Akash A.Patel,Prashant S.Bajaj .
- 11.Stress Analysis On Steering Knuckle Of The Automobile Steering System By B.Babu,M.Prabhu,P.Dharmaraj And R.Sampath.
- 12.Introduction To Material Selection Charts From Advanced Physics.
- 13.Materials Selection In Mechanical Design By M.F.Ashby And D.Cebon.

14.Design And Shape Optimization Ofa Steering Knuckle Of An Off-Road Vehicle Using Solidworks And Ansys Workbench By Jatin Agarwal.

15.Fea Of A Steering Knuckle For Life Prediction By Sharad Kumar Chandrakar,Dheeraj Lal Soni And Shohel Gardia.

16.Fatigue And Impact Analysis Of Automotive Steering Knuckle Under Operating Load Cases By V.Sivananth S.Vijayarangan And R.Aswathaman.

17.Design And Development Of Steering Knuckle With Spindle And Its Optimiztion –A Review By Ankur V.Kamble, Prof S.S. Patil, Prof M.L Harugade, Prof P.S.Pol.

18.Material Composition By Azom.