

## DATA TRANSMISSION THROUGH LI-FI

**Prof. Prajakta Jadhav<sup>1</sup>, Shazia Khatib<sup>2</sup>, Kaisahemd Maner<sup>3</sup>**

<sup>1</sup>Assistant Professor & TC, Dr.D.Y.Patil Institute of Engg. Management and Research, Pune, Maharashtra, India

<sup>2</sup>Student, E&TC, Dr.D.Y.Patil Institute of Engg. Management and Research, Pune Maharashtra, India

<sup>3</sup> Student, E&TC, Dr.D.Y.Patil Institute of Engg. Management and Research, Pune Maharashtra, India

\*\*\*

**Abstract** – The following paper clarifies the use of visible light spectrum for data communication. In particular, it will show how Li-Fi enhances VLC by using light emitting diodes (LEDs) to implement fully networked wireless system. Li-Fi can be a new contribution in one of the efficient wireless data transmission systems. Due to its excellent speed feature it holds a great scope in future application. Using the concept of Li-Fi we are implementing a module wherein a buggy is being drove based on commands sent through LED light.

**Key Words:** VLC (visible light communication), LED (light emitting diodes, Li-Fi(Light fidelity),Wi-Fi(wireless Fidelity).

### 1. INTRODUCTION

Due to the escalating use of wireless data communication, the present radio spectrum below 10 GHz (cm-wave communication) is getting saturated. Researchers in wireless technology have responded to this problem by considering the upper layer of the spectrum i.e. the VLC spectrum .Li-Fi is a newly emerged wireless technology that has the scope of providing efficient and best connectivity within indoor network environment. The prior essence of this technology is that it enables us to send the information with the help of light illumination. At the University of Edinburgh in an ongoing conference, Prof. Harald Hass showed how vlc can be used for data communication. He demonstrated this by sending a HD video within just a few seconds with the help of light illumination .The term Li-Fi was thus coined by him i.e. light fidelity. He foresees a future where a normal led bulb in a room could be used for data communication for devices like mobile phones, laptops, computers etc. Additional boon to this technology is security as light cannot be seen therefore data cannot be accessed.

#### 1.1 VLC (Visible Light Communication):

That part of the VLC spectrum which is visible to the human eye is the visible light spectrum.The visible light is the electromagnetic radiation in this range of wavelengths. The band width of this spectrum corresponds to 430-770 THz

Imagine that how a flash light can be used to send the mores code. If the flash light is made on and off very quickly according to the binary data of user requirement we get a system wherein there is communication plus illumination.

This can now be defined as visible light communication. For this just the provision of transreciever is need to be done which is not at all a difficult part. Thus we can see the light but not the data. This gives us an idea of what VLC specifies or is meant.



**Fig -1:** Visible Light Communication.

#### 1.2 objective:

The main objective is to make data transmission through light with the help of LI-FI . In this system there two are modules one of which is sender and other is receiver. At the sender side a circuit modulates light current and illuminates the LEDs according to the data we wish to transmit. At the receiver side there is a decoder circuit which actually consists of an octo-coupler. Initially it will sense the flicker in light and give information to the controller so that controller can drive dc motor according to the data received.

### 2. Analogy

Table below shows the the parameter of Li-Fi analogues to Wi-Fi. It highlights the key features of Li-Fi.

**Table -1:** Features of Li-Fi & Wi-Fi.

Parameter	LI-FI	WI-FI
Speed	High	High
Spectrum	Wider 10000 times	Relatively much narrow
Data Density	High	Low
Security	Much secure coz light cannot pass through solid objects	Not that secure coz this system is more transparent.
Reliability	Medium	Medium
Bandwidth	High due to broad spectrum	Low
Ecological Impact	Low	Medium
Obstacle Interference	High	Low
Bill of Material	High	Medium
Market Maturity	Low	High
Latency	In microseconds	In milliseconds

### 3. Scope of Li-Fi:

Li-Fi is still in its incipient stages and thus offers tremendous scope for future research and innovation. The following is a brief review of research being conducted in the field and future scope of this technology. Researchers are developing micron sized led's .which flicker 1000times faster than normal LED's. They provide faster data transfer and also take up less places. Moreover 1000 micron led's can fit into area required 1sq mm large single led. A 1 sq. mm sized array of micron sized LEDs could hence communicate 1000×1000 (i.e. a million) times as much information as a single 1mm LED. Speed more than 10gbps is possible to be achieved. In the Heinrich Hertz Institute in Berlin, Germany, researchers have achieved data rates of over 500 megabytes per second by just using a standard white led.

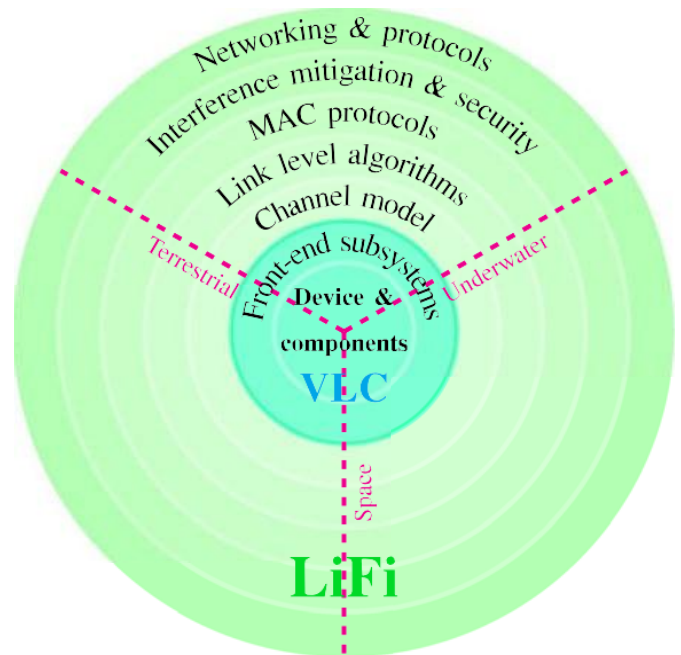

**Fig -2:** The principal building blocks of Li-Fi and its application areas

### 3. Proposed Work

The proposed plan of action is to make a system working on optical wireless communication. This model should effectively be able to transmit data from one device to another using LEDs. The system block diagram to be used in is as follows it consist of transmitter and receiver section.

#### 3.1 Transmitter section:

The transmitter section consist of the data input which is fed into the raspberry pi via the Wi-Fi system which is inbuilt in the raspberry pi-3. The data inputs is nothing but the commands that are built into the android app. the raspberry pi controls the flickering of the interfaced LEDs according to the command (data) fed into it with the help of the Li-Fi transmitter circuit.

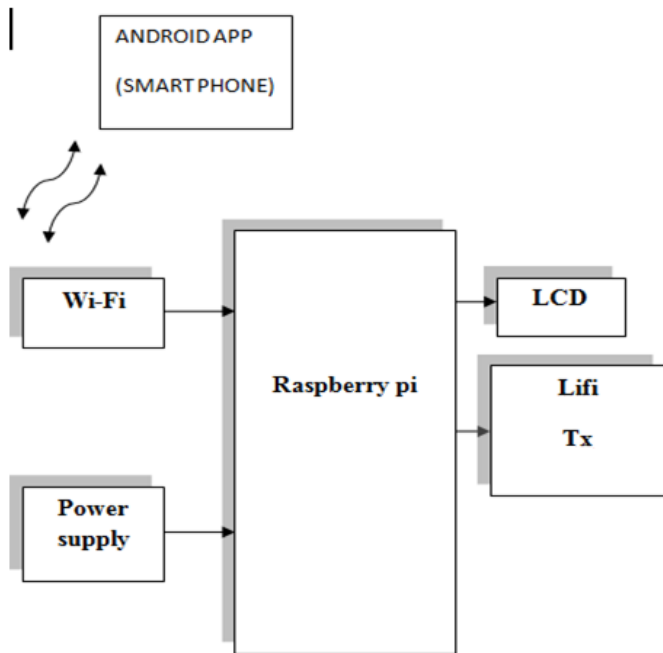

Fig -3: Li-Fi transmitter section

### 3.2 Receiver section:

The flickering of the LEDs is detected by the photo diode on the receiving circuit of the Li-Fi. This modulated data is then fed into the microcontroller (i.e. PIC 16f877). The controller then controls the gestures of the interfaced motor with the help of motor driver according to the given command (data).

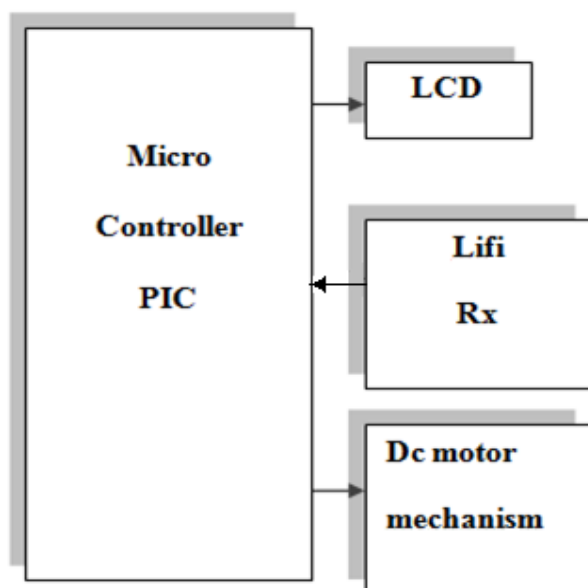
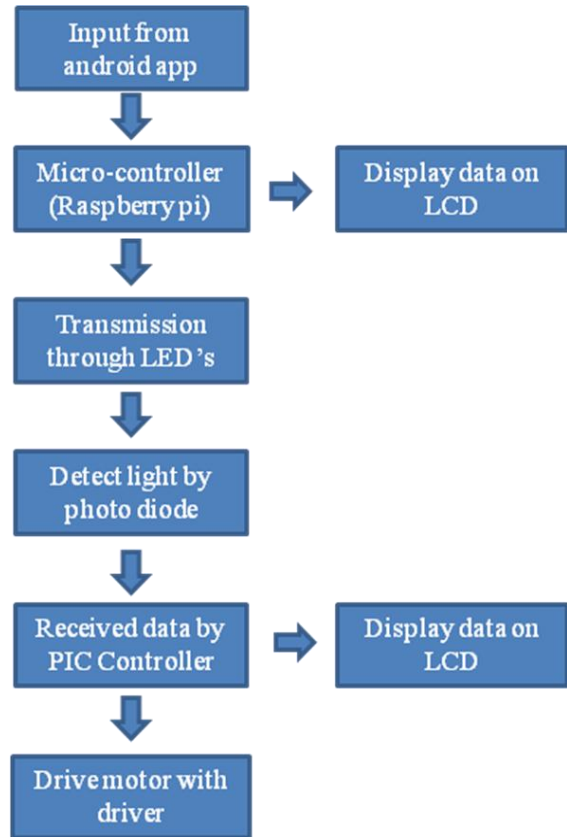

Fig -4: Li-Fi receiver section

### 3.3 Flowchart:

The work flow of the project is as follows



### 4. Advantages:

- Visible light spectrum is 1000 times wider with compare to the radio wave spectrum.
- Li-Fi is a harmless alternative as compared to radio waves (RF), because in RF waves the electromagnetic interference takes place in environments such as in mines and petrochemical sectors.
- Li-Fi makes use of a free band that does not need any licensing high speed it offers theoretical speed in the order of gigabits/sec.
- Wi-Fi does not work underwater but Li-Fi does and hence can be used for undersea explorations.
- LED lights eat less energy and are very competent. As it uses less energy it is economical and easy to use.

### 5. Disadvantages:

- The major disadvantage of this technology is that light cannot pass through obstacles. Therefore it cannot pass through walls and many such objects and can be blocked easily. We can seamlessly change back over to radio waves in such a case.

- The signal will be cut out if the receiver gets covered completely.

## 6. Applications:

- Light waves don't emit radiations as that of radio waves. So it is less harmful as compared to the RF waves. Therefore they can be used where radiation is the critical parameter.
- Street lights can be used in future as Li-Fi hotspot. They can also be used to control and monitor the data.
- Li-Fi is extremely useful in communication where security is the major aspect. These involve various military applications.
- Wi-Fi is often prohibited in aircrafts. However, since aircrafts already contain multiple lights, thus Li-Fi can be used for data transmission.

## 7. CONCLUSION

Using the concept of Li-Fi this model can be implemented which depicts how light can be used for transfer of data. Many such applications are possible using Li-Fi coz of its great future scope and multiple benefits. Li-Fi enhances the new technology to extract the maximum benefits out of it.

## REFERENCES

- [1] Mrs.Padmini Mishra, Mrs Jyoti Potadar, Mrs.Sonu Priya "A review of LIFI:green WI-FI" MARCH 2016 IRJET(International research journal of engg and tech).
- [2] M.Afgani, H.Haas, H.Elgala and D.Knipp, "Visible Light Communication using OFDM" in Proc. of the 2nd International Conference on Test beds and Research Infrastructures for the Development of Networks and Communities (TRIDENTCOM), Barcelona, Spain, March 1-3 2006, pp. 129-134
- [3] Dhakne Vikas, Ravi Nibalkar "Light fidelity: A reconnaissance of future tech" Nov 2013, IJARCSSE (International Journal of Advance Research in Computer Science and Software engineering.)
- [4] R.Kartika, S.Balakrishnan, "Wireless communication using Li-Fi tech", s3 march 2015 IJECE(International Journal of Electrical and Computer Engineering)
- [5] M.Afgani, H.Haas, H.Elgala and D.Knipp, "Visible Light Communication using OFDM" in Proc. of the 2nd International Conference on Test beds and Research Infrastructures for the Development of Networks and Communities (TRIDENTCOM), Barcelona, Spain, March 1-3 2006, pp. 129-134.
- [6] H. Haas, "Wireless data from every light bulb", TED Website, Aug. 2011. [Online]. Available: [http://bit.ly/ted\\_vlc](http://bit.ly/ted_vlc).
- [7] H. Elgala, R. Mesleh, and H. Haas, "Indoor Optical Wireless Communication: Potential and State-of-the-Art", IEEE Communications Magazine, vol. 49, no. 9, pp. 56-62, Sep. 2011, ISSN: 0163-6804.
- [8] [technopits.blogspot.com/technology/cgap.org/2012/01/11/a-lifi-world](http://technopits.blogspot.com/technology/cgap.org/2012/01/11/a-lifi-world)
- [9] <http://www.extremetech.com/computing/152740-researchers-create-3gbps-lifinetwork-with-led-bulbs>
- [10] Li-Fi (Light Fidelity)-The future technology In Wireless Communication Neha Singh, International Journal of advances in computing & communications, vol. 1, 2013 www.ijacc.org
- [11] [seminarprojects.com/s/seminar-report-on-li-fi](http://seminarprojects.com/s/seminar-report-on-li-fi)
- [12] [the-gadgeteer.com/2011/08/29/li-fi-internet-at-the-speed-of-light](http://the-gadgeteer.com/2011/08/29/li-fi-internet-at-the-speed-of-light)
- [13] "Visible-light communication: Tripping the light fantastic: A fast and cheap optical version of Wi-Fi is coming", Economist, dated 28Jan 2012.
- [14] International Journal of Applied Engineering Research, ISSN 0973-4562 Vol.7 No.11 (2012) <http://www.ripublication.com/ijaer.html>