

# Sensitivity of the MEMS based Piezoresistive Wind Speed Sensor with Comparative Study of Different Shapes of Paddles

Amandeep Kaur Dhonkal<sup>1</sup>, Vimal Agarwal<sup>2</sup>, Kanchan Sengar<sup>3</sup>

<sup>1</sup>Scholar, Dept. of ECE, JECRC University, Jaipur, Rajasthan, India

<sup>2</sup>Associate Professor, Dean Academics, Apex Institute of Technology, Jaipur, Rajasthan, India

<sup>3</sup>Assistant Professor, Dept. of ECE, JECRC University, Jaipur, Rajasthan, India

\*\*\*

**Abstract** - MEMS (Micro-Electro-mechanical System) technology is one of the prominent technologies which has many advantages such as high accuracy, low cost and small size. Conventional rectangular beam cantilever are based on detection of the surface stress of the beam, generated due to the speed of the wind. Stress induced in the microcantilever beam is affected by the area of the cantilever. In this paper we have designed a piezoresistive microcantilever based wind speed sensor. The finite element method (FEM) is used to investigate the shape distortion and stress dissemination. The software Comsol multiphysics 4.4 is used to examine the linking characteristics between the material and the fluid. A comparative study for different shapes of paddle such as hexagonal, rectangular and triangular has been performed. The effect of different shapes on the stress induced has been compared, keeping the area of the shapes constant. The simulation results show that the triangular shaped paddle results in higher sensitivity of the sensor. The sensitivity of the respective wind speed sensor comes out to be 0.20402825 mV/ms<sup>-1</sup>.

**Key Words:** MEMS, FEM, Microcantilever, Paddles, Differential pressure.

## 1. INTRODUCTION

Microcantilever is a component which is widely used in micro system devices and provides a good platform for various sensitive sensors. A cantilever is a device which is fixed on one end and movable on the other [1, 2]. Load is applied at the free end of the cantilever that results stress at the surface of the cantilever. A micro cantilever detects the change occurred in stress when the cantilever bends or change in the frequency due to vibration, hence widely used as physical, chemical or biological sensor. Micro cantilevers have become so popular from past few years because of their selectivity, high sensitivity and flexibility of on-chip circuits and ease of fabrication. It provides a wide range in industrial applications due to convenience to regulate and readily adjustable into unified electromechanical system. Micro cantilever sensors can be used in any medium such as air, vacuum or liquid.

This paper provides details about the finite element method (FEM) to acquire the accurate performance of microcantilever sensor with different shapes of paddles such as hexagon, rectangle and triangle. Finite element method (FEM) is used for simulations and analytical calculations for various shapes and geometries of the cantilever paddles [3, 4]. Different shapes of paddle of the cantilever beam using structural mechanics module of Comsol multiphysics 4.4 has been designed and simulated. The result of stress induced due to the different shapes are compared to obtain the sensitivity of the sensor

## 2. DESIGN AND OPERATING PRINCIPLE

### 2.1 Basic Structure

Static and dynamic characteristics are firstly considered for designing a micro-sensor. The structure of the microcantilever should have enough strength and should be suitable for external connections and easy to install.

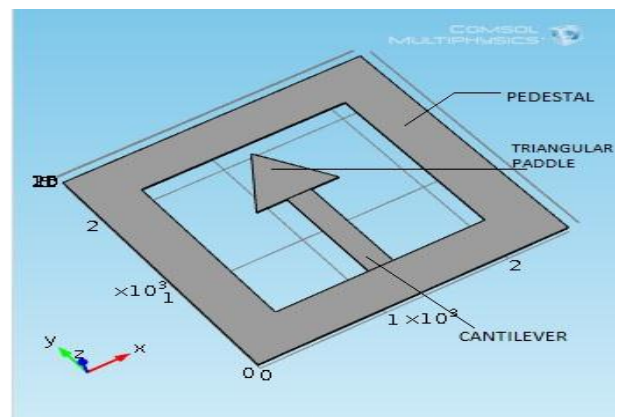

Fig -1: Structure of the sensor

As shown in Fig -1, the sensor consists of pedestal, cantilever and triangular shaped paddle. Pedestal, cantilever and triangular shaped paddle have the same thickness. By placing the paddle at the free end of the cantilever, the sensitivity can be enhanced. Poly-Si is used as a material for the structure of the sensor. Then, a piezoresistive layer of the P type Si has been placed over the Poly-Si layer. One out of four piezoresistor is incorporated on the cantilever and a Wheatstone bridge is formed, as shown in the Fig -2.

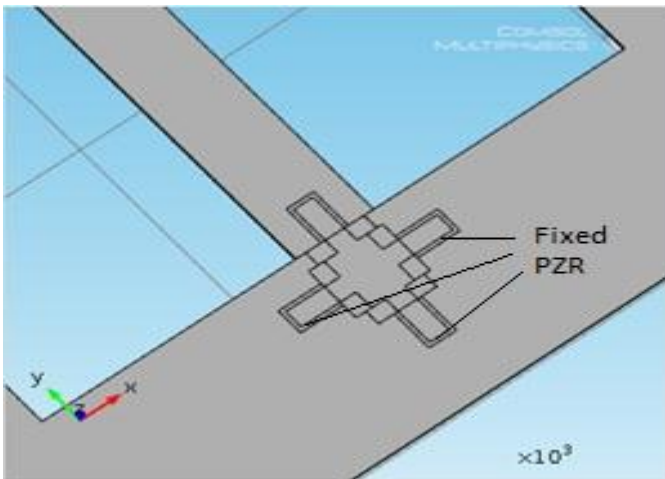

Fig -2: Placement of piezoresistors

When the fluid flows through the sensor, differential pressure occurs between top and bottom surface of the cantilever, the cantilever produces deformation and resistance of the piezoresistor changes thereby, breaking the balance of the Wheatstone bridge [3]. Then this change in resistance can be detected in the form of voltage at the output terminal of the bridge.

## 2.2 Principle

In this design, the sensor consists of piezoresistive sensing layers and the supporting layer. When the fluid flows through the sensor, differential pressure  $\Delta P$  occurs between top and bottom surface of the cantilever that can be written as follows [5]

$$\Delta P = \frac{C_d \rho V^2}{2} \quad (1)$$

Where  $\rho$  is the fluid density,  $V$  is the flow velocity and  $C_d$  is the drag coefficient, which is related to the Reynolds number. The Reynolds number is given by

$$R_e = \frac{V \times L}{k} \quad (2)$$

Where  $V$  is the flow velocity,  $L$  is length of flow and  $k$  is kinematic viscosity of fluid respectively. According to the differential pressure  $\Delta P$ , the force  $\Delta F$  on top surface of the cantilever can be calculated as follows

$$\Delta F = \Delta P \times A \quad (3)$$

Where  $A$  is area of the cantilever. When the force caused by the wind speed acts on the cantilever, it causes a displacement  $D$  which is given by modified Stoney's formula

$$D = 3 \times \sigma \times \left(\frac{1-\nu}{E}\right) \times \left(\frac{L}{t}\right)^2 \quad (4)$$

Where  $\sigma$  is stress gradient generated,  $\nu$  and  $E$  are Poisson's ratio and Young's modulus of the material of the cantilever.  $L$  and  $t$  are the length and thickness of the cantilever respectively. The sensitivity of the sensor can be optimized by the stress analysis.

## 3. MEMS SENSOR MODEL

In this study, a MEMS based wind speed sensor is designed using the software Comsol multiphysics 4.4. A comparative study is done among three different shapes of the paddle placed at the free end of the cantilever.

Three shapes of paddle selected for the comparative study are hexagon, rectangle and triangle. Cantilever beams are made of two layers, top layer is sensing layer and the bottom layer is the supporting layer. Poly-Si is used for the supporting layer and sensing layer is made of P-type Si with dopant density of  $1.32 \times 10^{19} (1/cm^3)$ . Dimensions of the cantilever, piezoresistor and paddles are shown in the Table -1 and Table -2 given below:

Table -1: Dimensions of the cantilever and piezoresistor

|               | Length       | Width       | Thickness  |
|---------------|--------------|-------------|------------|
| Cantilever    | 1000 $\mu$ m | 200 $\mu$ m | 20 $\mu$ m |
| Piezoresistor | 110 $\mu$ m  | 70 $\mu$ m  | 400nm      |

Table -2: Dimensions of the paddles

| Shape of paddle | Dimensions                   | Thickness  |
|-----------------|------------------------------|------------|
| Hexagon         | Side=277.5 $\mu$ m           | 20 $\mu$ m |
| Rectangle       | L=500 $\mu$ m, B=400 $\mu$ m | 20 $\mu$ m |
| Triangle        | Side=680 $\mu$ m             | 20 $\mu$ m |

The Fluid structure interaction (FSI) module of Comsol multiphysics 4.4 is used for the interaction of the solid and the fluid.

## 4. RESULTS AND DISCUSSION

The result shows the stress induced due to various shapes of the paddles. It can be seen from the Fig -3 that in case of Poly-Si, triangular shaped paddle gives the maximum stress but by changing the material, the results can be altered. In Table -3, the stress of different geometries has been compared at a same pressure of 200 Pa, based on the simulated geometries in the Comsol Multiphysics 4.4. For comparison of the effect of the shapes on the generated stress the area of all the shapes has been kept constant i.e.

$\approx 2 \times 10^5 \mu\text{m}^2$ . From the following comparisons, we can lead towards the best suited geometry for the wind speed sensor which gives us the optimum sensitivity as discussed in the later section.

**Fig -3:** Stress in cantilever due to: (a) Hexagonal paddle (b) Rectangular paddle (c) Triangular paddle

**Table -3:** Stress and displacement analysis

| Shapes             | Stress(N/m <sup>2</sup> ) | Displacement (μm) |
|--------------------|---------------------------|-------------------|
| Hexagonal paddle   | $5.13 \times 10^6$        | 1.92              |
| Rectangular paddle | $5.16 \times 10^6$        | 1.71              |
| Triangular paddle  | $5.17 \times 10^6$        | 2.02              |

From the results we can see that cantilever with triangular paddle gives maximum layer of piezoresistive material P-type Si and Fluid structure interaction (FSI) module of Comsol multiphysics 4.4 to analyze the interaction between the solid and the fluid. As the wind passes through the surface of the cantilever, the wind exerts pressure on the cantilever which results in stress and displacement induced on the surface of cantilever as shown in the Fig -4.

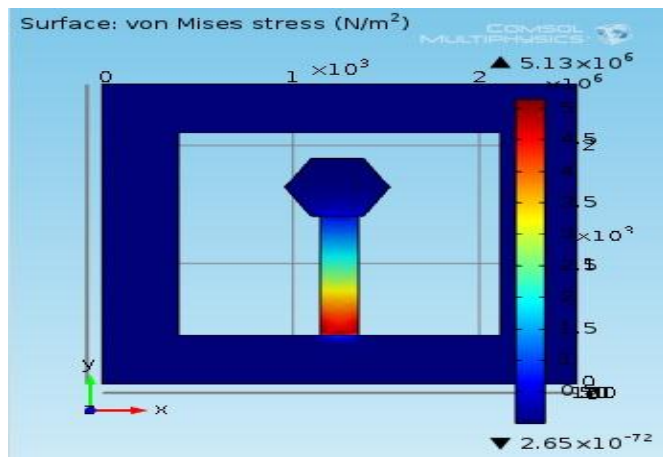

(a)

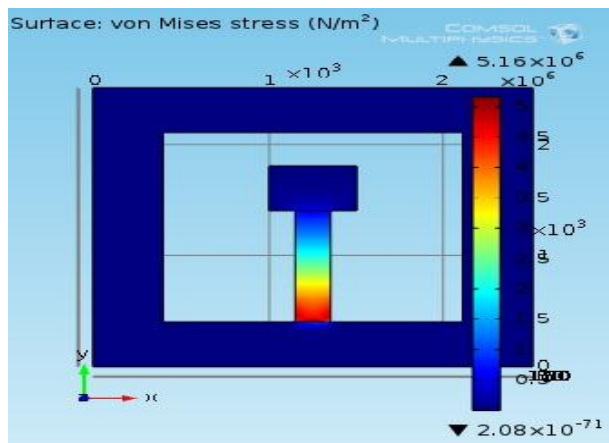

(b)

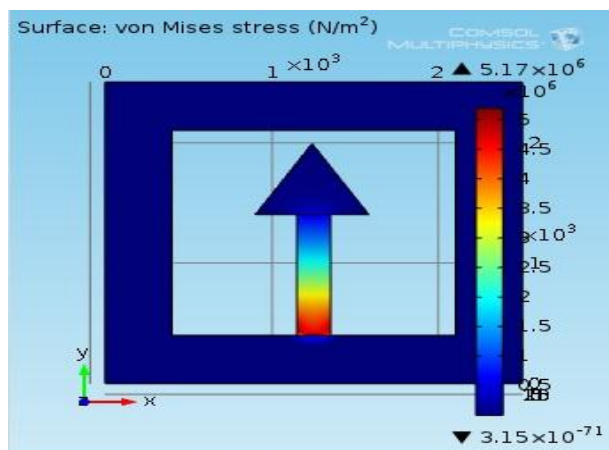

(c)

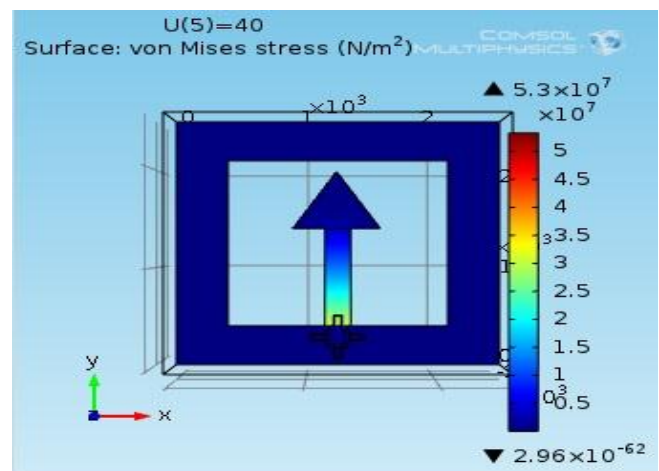

(a)

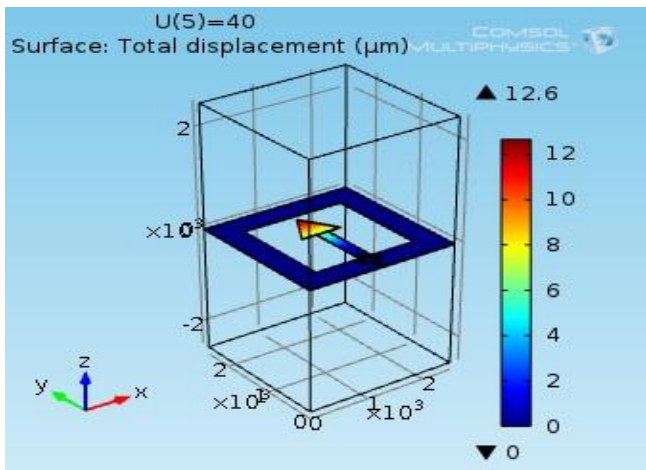

(b)

**Fig -4:** (a) von Mises stress generated at wind speed 40m/s (b) Total displacement at wind speed 40m/s

The wind speed ranges from 20m/s to 40m/s. Fig -5 represents the variation in the sensor stress as the wind passed over the cantilever surface at different wind speed. It is shown that the value of induced stress increases as we increase the wind speed. The value of stress and displacement at different wind speed is shown in Table - 4. The stress is converted into change in electrical resistance by the piezoresistor. This change in electrical resistance is converted into voltage change using Wheatstone bridge circuit.

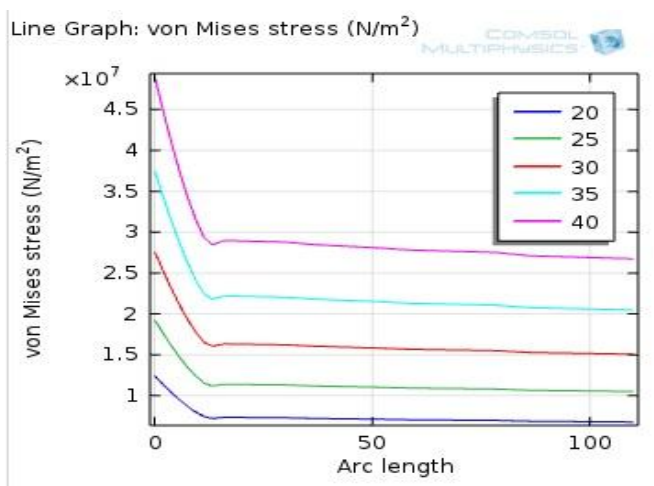

**Fig -5:** Graphical representation of von Mises stress at different wind speed (m/s)

**Table -4:** Stress and Displacement analysis at different values of wind speed

| Wind Speed (m/s) | Stress (N/m <sup>2</sup> ) | Displacement (μm) |
|------------------|----------------------------|-------------------|
| 20               | 1.34×10 <sup>7</sup>       | 3.2               |
| 25               | 2.08×10 <sup>7</sup>       | 4.95              |
| 30               | 2.99×10 <sup>7</sup>       | 7.1               |
| 35               | 4.06×10 <sup>7</sup>       | 9.65              |
| 40               | 5.3×10 <sup>7</sup>        | 12.6              |

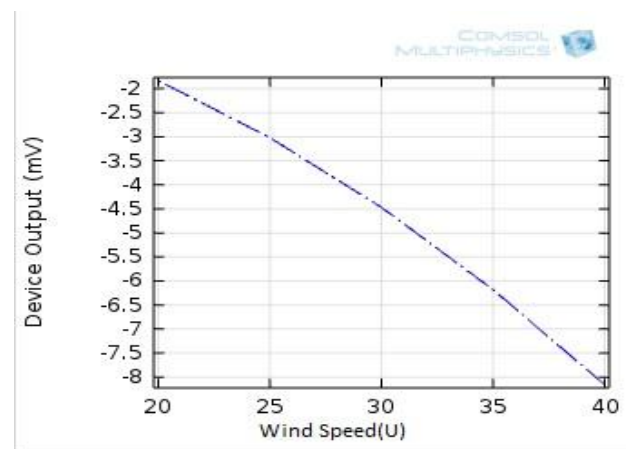

**Fig -6:** Output (voltage) of the sensor at different wind speed (m/s)

**Table -5:** Device output and variation in resistance at different wind speed

| Wind Speed (m/s) | Device Output (mV) | Change in Resistance (Ω) |
|------------------|--------------------|--------------------------|
| 20               | -1.82997           | 3.246043429              |
| 25               | -3.01815           | 5.317753757              |
| 30               | -4.46823           | 7.848354482              |
| 35               | -6.18239           | 10.84298291              |
| 40               | -8.16113           | 14.30384904              |

Fig -6 presents the output voltage signal of the sensor at different wind speed. The measured values of the sensor at different wind speed 20, 25, 30, 35 and 40 m/s are shown in Table -5. It is inferred that there is increase in the resistance variation as the wind speed increases. The proposed wind speed sensor exhibits a sensitivity of 0.20402825 mV/ms<sup>-1</sup>.



In addition to its high sensitivity the model also has a wide wind speed range.

## 5. CONCLUSION

The microcantilever based wind speed sensor has been designed. A comparative study is done among the three different shapes of the paddles, placed at the free end of the cantilever and Fluid structure interaction (FSI) is used for the interaction between the solid and the fluid to determine the sensitivity of the sensor. It is observed that the triangular shaped paddle produces maximum stress i.e.  $5.17 \times 10^6$ . The wind speed varies between 20 m/s to 40 m/s. In the sensing operation, the wind speed is observed by measuring the change in resistance of the piezoresistive layer deposited on the cantilever beam's surface as the cantilever beam deforms under the effect of the passing wind speed. The observed maximum sensitivity is  $0.20402825 \text{ mV/ms}^{-1}$ .

## REFERENCES

- [1] V. Mounika Reddy and G.V.Sunil Kumar, "Design and analysis of microcantilevers with various shapes using COMSOL multiphysics software", International Journal of Emerging Technology and Advanced Engineering, vol. 3, Issue 3, March. 2013.
- [2] Yu-HsiangWang, Tzu-HanHsueh, Rong-Hua Ma, Chia-YenLee , Lung-MingFu, Po-ChengChou and Chien-HsiungTsai, "A microcantilever-based gas flow sensor for flow rate and direction detection", ISBN: 978-2-35500-006-5, pp. 142-145, DTIP of MEMS & MOEMS, 2008
- [3] Pei Chen, Yulong Zhao and Yiyao Li, "Design, simulation and fabrication of a micromachined cantilever-based flow sensor", pp. 681-684, IEEE, NEMS 2013.
- [4] Ashish and T. Shanmuganatham, "A micromachined cantilever based flow rate and flow direction sensing scheme", International Conference on Communication and Signal Processing, pp. 434-437, IEEE, 2014.
- [5] Uday Jyoti Gogoi and Dr. T. Shanmuganatham, "Sensitivity enhancement of MEMS fluid flow rate and flow direction sensor", 2014 International Conference on Smart Structures & Systems (ICSSS-2014), pp. 123-126, IEEE, 2014.