

# Experimental Analysis to Optimize the Process Parameter of Friction Stir Welding of Aluminium Alloy(AA6082)

D.M. Nikam<sup>1</sup>, N.V. Paithankar<sup>2</sup>, A.S. More<sup>3</sup>, A. B. Bansode<sup>4</sup>, S.B. Deokar<sup>5</sup>

<sup>1</sup>BE Student, Mechanical, SND COE & RC, Yeola, Maharashtra, India

<sup>2</sup>BE Student, Mechanical, SND COE & RC, Yeola, Maharashtra, India

<sup>3</sup>BE Student, Mechanical, SND COE & RC, Yeola, Maharashtra, India

<sup>4</sup>BE Student, Mechanical, SND COE & RC, Yeola, Maharashtra, India

<sup>5</sup>Asst. Prof. Mechanical, SND COE & RC, Yeola, Maharashtra, India

\*\*\*

**Abstract** - In many industrial applications steel is replaced by non-ferrous alloys like aluminium alloys. Aluminium alloys having good mechanical properties as compared to structural steel and low weight it allows a significant reduction in weight. But the welding of aluminium alloy by conventional processes can causes serious problems. The difficulties are like loss of alloying elements and presence of the segregation and porosities in the weld joint. Friction stir welding (FSW) is a solid state welding process, which eliminates all these problems of solidification associated with the traditional fusion welding processes.

In this research work the attempt has been made to develop an empirical relationship between FSW variables (tool rotation, tilt angle and welding speed) and tensile strength and yield strength of single pass and multi pass friction stir welded aluminium alloy 6082 butt joints. Taguchi method and particle swarm optimization technique was adopted for the analysing the problem in which several independent variables influence the response. Three-factors three level central composite design was used to find the optimal factors of friction stir welding process for aluminium alloy.

**Index Term:** Design of experiment, Friction stir welding, Taguchi method.

## 1. INTRODUCTION

In today's modern world there are various welding techniques to join metals. They range from the conventional oxyacetylene torch welding to the laser welding. The two types of welding can be separated as fusion welding and pressure welding. The fusion welding is the process involves bonding of the metal in the molten stage and may need a filler material if required such as a unpreserved electrode or a spool of wire. Some processes may also need an inert ambience in order to avoid corrosion of the molten metal. A flux material or an inert gas shield in the weld zone protects weld pool to avoid defects. Examples of fusion welding are metal inert gas welding (MIG), tungsten inert gas welding (TIG) and laser welding. There are a lot of disadvantages in the welding techniques where the metal is required to melt. Temperatures and let it the harden to form the joint. The melting and solidification causes the mechanical properties of the weld in some cases to get worse such as low tensile strength, fatigue strength and ductility. The disadvantages

also include porosity, oxidation, micro segregation, hot cracking and other microstructure defects in the joint. The process also limits the combination of the metals that that can be joined because of the different thermal coefficients of expansion.

From the literature survey the various material of aluminum serious is tested but the aluminum alloy of 6082 is remain so I selected this material.

## 1.1 NEED OF FRICTION STIR WELDING

More than 100, 00,000 workers in the world are currently employed full time as welders, while higher number of workers performs welding intermittently as part of their job. A number of epidemiologic studies have reported a higher incidence of respiratory ill health in welders. Respiratory effects observed in full-time welders have included bronchitis, airway irritation, metal fume fever, chemical pneumonitis, lung infection changes, and a possible increase in the incidence of lung cancer. It is important to reduce welding fume toxicity and exposure whenever possible. Jayaraman states the effect of friction stir welding process parameters on tensile strength of cast LM6 aluminum alloy also the quality of weld zone was investigated using macrostructure and microstructure analysis. They proposed that about the 12 joints fabricated, that the joint made-up using the process parameters of 900 r/min (tool rotation speed), 74 mm/min (welding speed) and 3 KN and (axial force) yielded higher tensile strength compared to other joints.

## 1.2 METHODOLOGY

For the welding purpose the plates of aluminum AA6082 were prepared then these plates were welded by using a square profile tool with single pass and double pass. The specimens were prepared and tested on universal testing machine. The obtained results of the tensile strength were optimized by using the optimization techniques like ANNOVA and PSO. Thus optimum values were found. The flow chart given below represents the methodology for the project. Friction Stir Welding is a simple process in which the rotating cylindrical tool with a shoulder and a profiled pin is plunged into the plates to be joined and traversed along the line of the joint. The plates are tightly clamped on the bed of

the FSW equipment to prevent them from coming apart during weld.

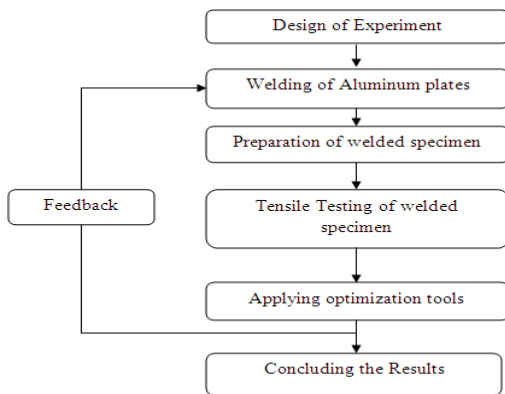

**Fig.1: Flowchart for Actual Process to be carried out during FSW**

A cylindrical tool rotating at high speed is gradually plunged into the plate material, until the shoulder of the tool touch the upper surface of the material. A downward force that is applied to maintain the contact. Frictional heat, generated between a tool and the material, causes that the plasticized material to get heated and softened, without reaching the melting point. The tool is then traverse along with the joint line, until it reaches the end of the weld.

As the tool is then moved in the direction of welding, the leading edge of the tool that forces the plasticized material, on either side of the line, to the back of the tool. In effect, the transferred material is forged by that the close contact of the shoulder and the pin profile. In order to achieve the complete through thickness welding, the length of the pin should be slightly less than a plate thickness, since only limited amount of deformation occurs below the pin. The tool is generally tilted by 2 to 4°, to facilitate better consolidation of the material in the weld.

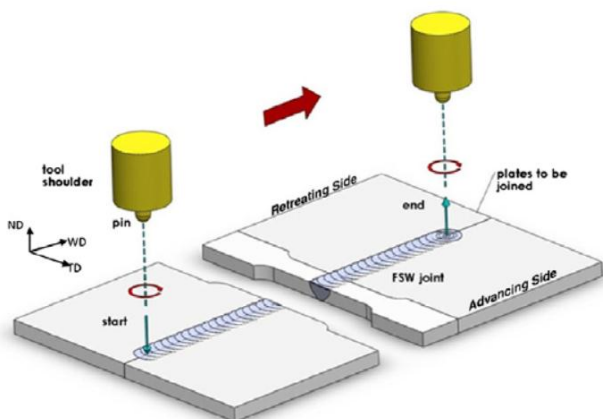

**Fig.2: Schematic representation of FSW process and tool profile**

### 1.3 EXPERIMENTAL METHOD

#### 1.3.1. Design of Experiments

Design of experiments is a method of designing experiments, in which only selected number of experiments are to be performed. For example if there are three parameters with three levels for each parameter, then the total number of experiments to be performed is  $3^3= 27$  experiments. But using design of experiments method, only 9 experiments are needed to be performed. On the basis of these 9 experiments, the significance and optimal levels of each parameter is obtained. According to the L9 orthogonal array, 3 experiments in each set of process parameters have been performed on IS 3039 plates. The 3 factors used in this experiment are the rotating speed, tool tilt angle and travel speed. The experiment notation is also included in the L9 orthogonal array which results in an on additional column, in order to represent the parameters. The experiments are performed on the vertical milling machine which serves to perform the FSW operation. It is a well-known factor that at higher rotating speed, FSW produces high heat input and these 3 levels were selected as low, medium and high speed among the highest speeds available in the machine. Only at low travel speeds, the weld could be achieved with a shorter pin and hence the 3 least travel speeds were taken. Beyond the tool tilt angle of 2° the pin pierces out the plasticized material for the thickness of 3mm plate, and hence 0°, 1° and 2° tool tilt angles were taken. The various process parameters are as follows.

#### A. FIXED PARAMETERS

1. Force
2. Shoulder plunger
3. Penetration ligament
4. Tool pin profile

#### B. VARIABLE PARAMETERS

1. Tilt angle
2. Rotational speed
3. Welding speed.

### 1.4 TOOL DESIGN

#### Tool introduction

According to K.Ramanjaneyulu, G. Madhusudhan Reddy, A. Venugopal Rao, and R. Markandeya, Experiment was conducted with different tool pin profiles are (conical, triangular, square, pentagon, and hexagon cross sections) maintain that the same swept volume during the tool rotation. The pin-to-swept volume ratio varies due to

changes in the physical volume of the pin only. In other words, the pin-to-swept volume ratio varies due to changes in the physical volume of the pin only.

In our project work we had studied various papers and finally we have selected hexagonal.

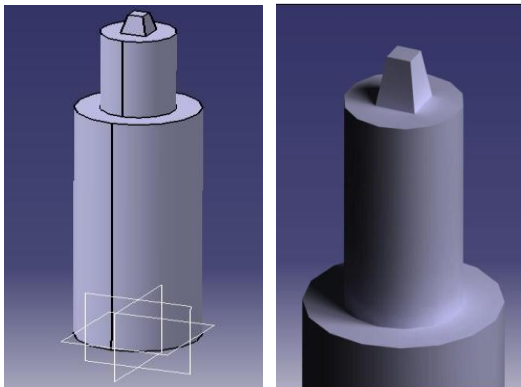

**Fig.3: Square tool profile**

### 1.5 WORK PIECE MATERIAL AA 6082-T6

Aluminum alloy 6082 is a medium strength alloy with good corrosion resistance. It has the highest strength of the 6000 series alloys. Alloy 6082 is known as a structural alloy. Typical composition limits are shown in Table No. 1. In plate form, 6082 is the alloy most commonly used for machining. As a relatively new alloy, the higher strength of 6082 has seen it replace 6061 in many applications. The addition of amount of manganese controls the grain structure which in turn results in a stronger alloy. It is difficult to produce thin walled, complicated extrusion shapes in AA6082. The extruded surface finish is not as smooth as other similar strength alloys in the 6000 series.



**Fig.4: Workpiece material**

In this investigation, the base materials, Al 6082-T6, which is a precipitation hardened aluminum alloy widely used in aerospace applications due to its high strength was used. FSW plates are examined using spectrometer. Table shows the mechanical properties of base metal AA 6082.

**Table -1: Sample Table format**

Element	Si	Fe	Cu	Mn	Mg	Cr	Ni	Zn
Composition in %	0.75	0.18	0.01	0.04	0.42	0.01	<0.005	0.01
Element	Ti	Pb	Sn	V	Zr	Sr	Al	
Composition in %	0.02	<0.005	0.01	0.01	<0.005	<0.001	98.1	

**Table -2: Mechanical Properties of Base Metal AA6082**

Material	Hardness(HV)	Ultimate Strength(MPa)	% Elongation
AA6082	95	250	10

Plate of size 160x20x5 mm is selected for testing of tensile strength on universal testing machine. The aim for machining both sides of the plates is to make them parallel for the FSW machine clamping system. The parallel plates enabled the uniformity in welding the gaps between the plates.

### 1.6 MATERIAL SELECTION OF TOOL FOR FRICTION STIR WELDING

Friction stirring is the thermo mechanical deformation process where the tool temperature approaches the solidus temperature of base metal. Production of a quality friction stir weld requires the proper tool material selection for the desired application. Naturally, there are important effects to the tool during welding: abrasive wear, high temperature and dynamic effects.

The following characteristics have to be considered for material choice,

1. Ambient and elevated temperature strength,
2. Elevated temperature stability,
3. Wear resistance,
4. Coefficient of thermal expansion,
5. Machinability

There are several tool materials to use depending on the base material:

1. Hot-work tool steels: the most commonly used material, easy availability and Machinability, wear resistance, especially for aluminum and copper.
2. Nickel- and cobalt base alloys: high strength, excellent ductility, hardness stability, these alloys derive their strength from precipitates, so the operational temperature must be kept below the precipitation temperature (typically 600 – 800 °C).
3. Refractory metals (W, Mo): high temperature strength, strongest alloys between 1000 – 1500 °C, expensive, difficult machining.
4. Tungsten-base alloys: good strength, high operational temperature, high cost (W-Re).

Carbide particle reinforced metal composites (WC, WC-Co, and TiC): superior wear resistance, reasonable fracture toughness.

### ACKNOWLEDGEMENT

We feel great pleasure to present the Dissertation entitled "**Experimental Analysis to Optimize the Process Parameter of Friction Stir Welding of Aluminium Alloy (AA6082)**". But it would be unfair on our part if we do not acknowledge efforts of some of the people without the support of whom, this dissertation work would not have been a success.

First and for most we are very much thankful to our respected Guide **Prof. Deokar.S.B** for his leading guidance in this dissertation work. Also he has been persistent source of inspiration to us. We would like to express our sincere thanks and appreciation to **Prof. Bhamre V.G.** (HOD) for valuable support. Most importantly we would like to express our sincere gratitude towards our **Friends & Family** for always being there when we needed them most

### REFERENCES

- [1] M. Jayaraman, R. Sivasubramanian, V. Balasubramanian, "Effect of Process Parameters on Tensile Strength of Friction Stir Welded Cast LM6 Aluminum Alloy Joints" Vol.25 No.5, (2009).
- [2] A. K. Hussain and S. A. P. Quadri, "Evaluation of Parameters of Friction Stir Welding For Aluminum AL6351 Alloy", International Journal of Engineering Science and Technology, Vol. 2, (2010).
- [3] K. Ramanjaneyulu, G. Madhusudhan Reddy, A. Venugopal Rao, and R. Markandeya, "Structure-Property Correlation of AA2014 Friction Stir Welds: Role of Tool Pin Profile", ASM International, MEPEG 22:2224-2240(2013).
- [4] B.T. Gibson, D.H. Lammlein, W.R. Longhurst, C.D. Cox, M.C. Ballun, K.J. Dharmaraj, G.E. Cook, A.M. Strauss, Journal of Manufacturing Processes 16 56-73(2014).
- [5] A. Pradeep, S. Muthukumar, "An analysis to optimize process parameters of friction stir welded low alloy steel plates", International Journal of Engineering, Science and Technology Vol. 5, No. 3, pp. 25-35, 2013.
- [6] Shrikant G. Dalu, M. T. Shete, "Effect of Process Parameters on Friction Stir Welded Joint: A Review", IJRET: International Journal of Research in Engineering and Technology eISSN: 2319-1163 | pISSN: 2321-7308
- [7] H.S Patil, S.N.Soman "Experimental study on effect welding speed tool pin profile on aluminium alloy" IJRET: International Journal of Research in Engineering and Technology Vol 2, No.5, 2010, pp 268-275.
- [8] Ahmed Khalid Hussain, Syed Azam Quadri "Evolution of parameters of friction stir welding for Aluminium AA 6351 alloy " International journal Science and technology vol No.2(10)2010, pp 5977-5984.
- [9] Dawes C. Wayne T., "Friction stir joining of aluminium alloys", TWI Bulletin, No.6, 1995.

- [10] Thomas W. M. et al "Friction Stir Butt Welding", International Patent Appl. No. PCT/GB92/02203, GB Patent Appl. No. 9125978.8 and U.S. Patent No. 5,460,317, 199.

### BIOGRAPHIES



Dattatray M. Nikam, SND COE Yeola, Pune University, Department of Mechanical Engineering.



Nitin V. Paithankar, SND COE Yeola, Pune University, Department of Mechanical Engineering.



Akshay S. More, SND COE Yeola, Pune University, Department of Mechanical Engineering.



Abhijit B. Bansode, SND COE Yeola, Pune University, Department of Mechanical Engineering.



Prof. Sagar B. Deokar, SND COE Yeola, Pune University, Department of Mechanical Engineering.