

Three Phase AC to DC Boost Converter Using D-Q Theory

MAHADEV R. HADIAL

*Department of Electrical Engineering
Vadodara Institute of Engineering
Gujarat, India.*

Abstract—Thyristor Bridge rectifiers are employed to obtain dc regulated voltage from ac main. These rectifiers are inject harmonics in the utility, it has been overcome by passive or active filter but it is costly and bulky. This paper presents three phase AC to DC boost bidirectional converter using DQ theory based current control loop. This converter provide constant DC boost voltage from 3 phase AC voltage by closed loop control. This converter has boosted DC voltage with unity input power factor and harmonics free source current. Results are obtained by computer simulation/MATLAB.

Index Terms— bidirectional converter, DQ theory, harmonics, power factor correction.

I. INTRODUCTION

Earlier time thyristor Bridge rectifiers are employed to obtain dc regulated voltage from ac main. These rectifiers pollute the utility with low-order harmonics, which are difficult to filter. The continuous use of thyristor Bridge rectifiers injects current harmonic components into the power grid and increases reactive power demands and power system voltage fluctuations. Harmonic current components create several problems like Increase in power system losses. Oscillatory torques in rotating machinery. Significant interference with communication circuits that share common right-of-ways with AC power circuits, Overheating and insulator failures in transformers, rotating machinery, conductor and cables. Generates noise on regulating and control circuits causing erroneous operation of such equipment. Reactive power burden, low system efficiency, poor power factor, system unbalance and causes excessive neutral currents. Malfunctioning of the protective relays and untimely tripping, Failure of capacitor banks [4].

Modern three phase AC to DC converter researches have focused on providing a good input power factor and low line current harmonics distortion in order to satisfy different harmonic standards [2][4].

The PWM bidirectional converter draws a near sinusoidal input current while providing a regulated output dc voltage and can operate in the first and second quadrants of the voltage-current plane. Mostly, the control structure of a three-phase six switch PWM boost converter consists of an inner current and an outer voltage control loop

The merits of the current controlled boost converter are:

- It provides near sinusoidal currents, thus avoiding expensive low harmonics filters
- It is accomplished of unity power factor operation thus offering the option of power factor compensation

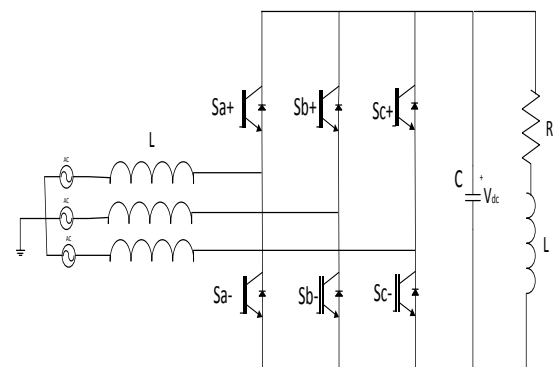

Fig.1 Three Phase AC to DC Boost Converter with R-L Load

II. DQ REFERENCE CURRENT GENERATION AND HYSTERESIS CURRENT CONTROL

This method of reference current generation is developed in time domain based reference current generation. This theory is extensively used as it simplicity of the calculations, and uses only algebraic calculation.

The three phase source current (I_{sa} , I_{sb} , and I_{sc}) are transformed into the two instantaneous active (i_d) and reactive (i_q) components in a rotating frame synchronous with the positive sequence of the system voltage. It can be represented by the set of equations. The basic working principle of SRF methods uses a direct (d-q) and inverse (d-q) park transformation method, which allow the evaluation of a specific harmonic component of the input signals.

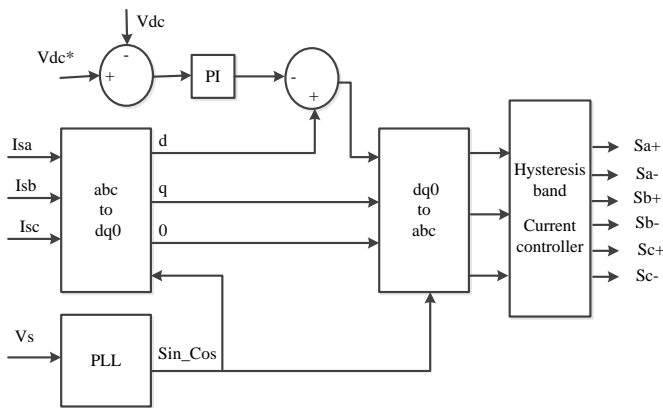

Fig.2 Control using D-Q Theory

The reference frame transformation is evaluated by converting a three-phase a - b - c stationary system to the two- phase direct axis (d) - quadratic axis (q) component rotating coordinate system. These three (a-b-c) phase space vectors stationary coordinates are easily transformed into two axis d-q rotating reference frame

$$\begin{bmatrix} i_d \\ i_q \\ i_0 \end{bmatrix} = \frac{2}{3} \begin{bmatrix} \cos \theta & \cos(\theta - \frac{2\pi}{3}) & \cos(\theta + \frac{2\pi}{3}) \\ -\sin \theta & -\sin(\theta - \frac{2\pi}{3}) & -\sin(\theta + \frac{2\pi}{3}) \\ \frac{1}{2} & \frac{1}{2} & \frac{1}{2} \end{bmatrix} \begin{bmatrix} i_a \\ i_b \\ i_c \end{bmatrix} \quad (1)$$

The output of the transformation depends on the source currents (fundamental and harmonic frequency components) and on phase locked loop. The PLL circuit of rotation speed (rad/sec) of the rotating reference frame ωt set as fundamental frequency component. The PLL circuit is providing $\sin \theta$ and $\cos \theta$ for synchronization [6].

The i_{sq} current component is applied to inverse transformation is used to compensate the reactive power. The dc side capacitor voltage of rectifier kept constant and controlled by using PI controller.

PI controller output is then subtracted from the direct axis (d axis) component. The method is further developed to get the desired reference current in d-q rotating frame is converted back into a - b - c stationary frame. This way reference current can be generated in a very easy method. The inverse transformation from d - q rotating frame to a - b - c stationary frame is achieved by the following equation [6].

$$\begin{bmatrix} i_a \\ i_b \\ i_c \end{bmatrix} = \begin{bmatrix} \cos \theta & -\sin \theta & 1 \\ \cos(\theta - \frac{2\pi}{3}) & -\sin(\theta - \frac{2\pi}{3}) & 1 \\ \cos(\theta + \frac{2\pi}{3}) & -\sin(\theta + \frac{2\pi}{3}) & 1 \end{bmatrix} \begin{bmatrix} i_d \\ i_q \\ i_0 \end{bmatrix} \quad (2)$$

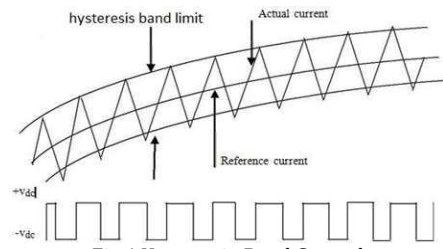

Fig.4 Hysteresis-Band Control

The hysteresis-band controller is used for the current control. After the inverse transform a-b-c current component is used for error. As the error exceeds a prescribed hysteresis band, the upper switch is turned off and the lower switch is turned on. As a results, the output voltage transitions from 0.1 to -0.1 V and the current starts decay. As the error crosses the lower band limit, the lower switch is turned off and the upper switch is turned on.

III. SIMULATION RESULTS

Simulation result is done using MATLAB/Simulink. Figure shows the Simulink diagram of bidirectional boost converter with R-L load. The diagram consists power circuit having bidirectional IGBT switches based converter with dc link capacitor and R-L load and control block which include D-Q theory reference current calculation and hysteresis current controller based switching pulse generation.

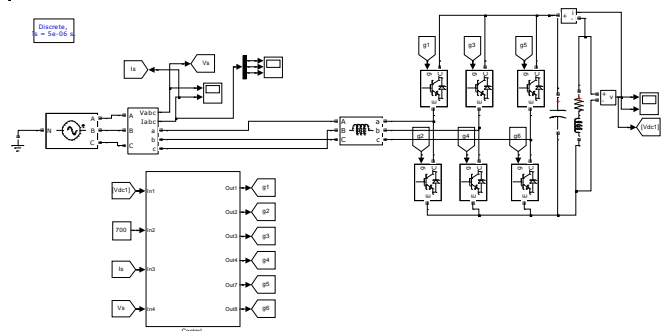

Fig.5 Simulink Diagram of AC to DC bidirectional Converter

Table.1 Parameters Used for Simulation

Parameters	Values
Source	440 VAC, 50hz
c	500μF
L (source side)	10mH
Load	100 Ω, 10mH
DC reference	700
PI gain	Kp = 1 Ki = 0.00001

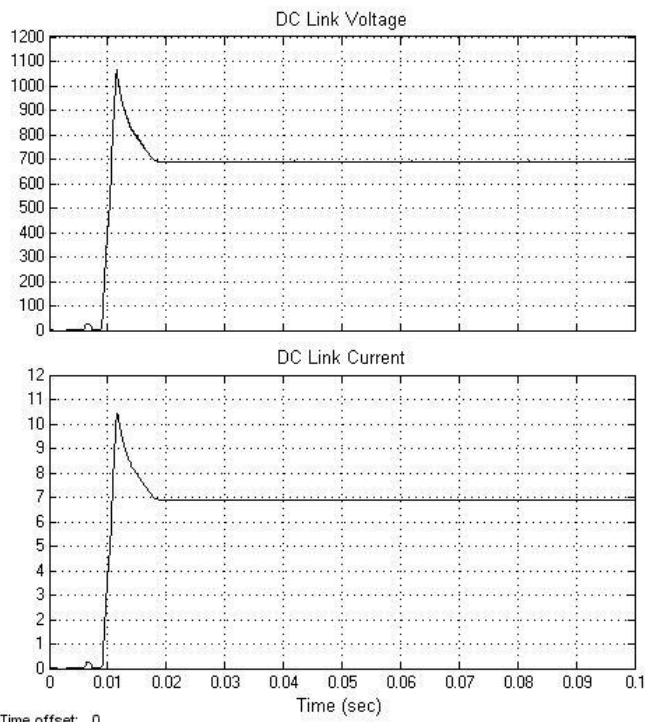

Fig.6 Waveform of DC link Voltage and Current

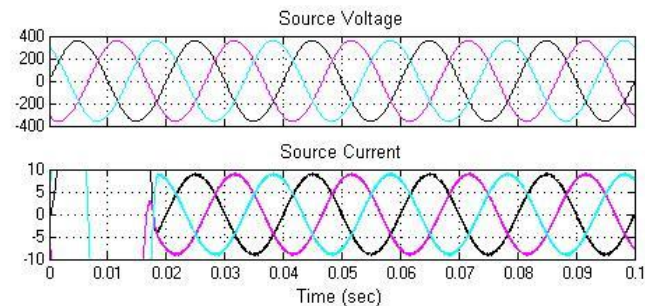

Fig.7 Source Voltage and Current

In the figure shows source current and voltage are in phase and current is all most sinusoidal so power factor is unity.

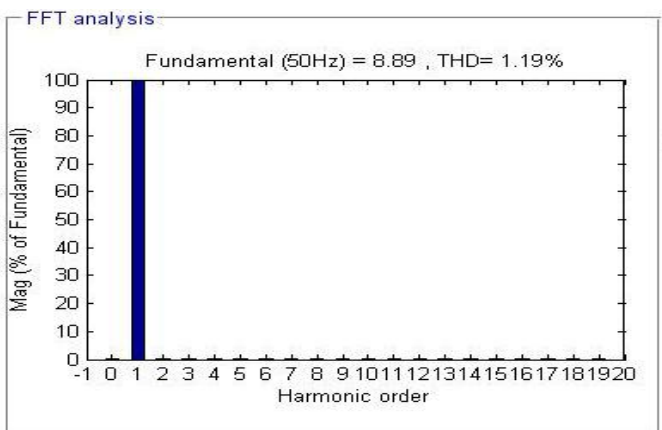

Fig.8 FFT analysis of source current

Table.2 Source Current with DC load current

Load		Idc (amp)	Source Current THD%
R (ohm)	L (mH)		
100	10	6.91	1.19
100	5	6.91	1.19
50	5	13.66	0.85
50	10	13.66	0.84
500	10	1.40	5.62
500	0	1.40	5.55

IV. CONCLUSION

This paper presents three phase AC to DC boost bidirectional converter using DQ theory based current control loop. This converter provide constant DC boost voltage from 3 phase AC voltage by closed loop control. This converter has boosted DC voltage with unity input power factor and harmonics free source current.

REFERENCES

- [1] Boon Tech Ool, Juan W. Dixon, Ashok B. Kulkarni, Masahiro Nishimoto, "An Integrated AC Drive System Using A Controlled Current PWM Rectifier/Inverter Link", IEEE Transactions On Power Electronics, Vol. 3, No.1, Jan 1988.
- [2] Jun Kikuchi, Thomas A. Lipo, " Three Phase PWM Boost Buck Rectifiers With Power Regeneration Capability", IEEE Transaction On Industry Applications, Vol. 38, No. 5, September/October 2002
- [3] J S Siva Prasad, Tushar Bhavsar, Rajesh Ghosh and G Narayanan, "Vector Control Of Three-Phase AC/DC Front-End Converter", Sadhan A Vol. 33, Part 5, October 2008, Pp. 591-613.
- [4] Dharmraj V. Ghodke, Sreeraj E. S., Kishore Chatterjee, And B. G. Fernandes," One-Cycle-Controlled Bidirectional Ac-to-Dc Converter With Constant Power Factor", IEEE Transactions On Industrial Electronics, Vol. 56, No. 5, May 2009.
- [5] G.Mohan Babu, "Simulation Study of Indirect Current Control Technique for Shunt Active Filter", International Journal of Engineering Research and Applications (IJERA) ISSN: 2248-9622 Vol. 3, Issue 4, Jul-Aug 2013, pp.831-851.
- [6] Neha Kumari, Isha Awashthi "Harmonic Compensation Using Shunt Active Power Filter in Power System Using Matlab", International Journal of Scientific Engineering and Research, Volume 1 Issue 3, November 2013.
- [7] S. S. Wamane, J.R. Baviskar, S. R. Wagh, "A Comparative Study on Compensating Current Generation Algorithms for Shunt Active Filter under Non-linear Load Conditions", International Journal of Scientific and Research Publications, Volume 3, Issue 6, June 2013.