

Vertical Axis Wind Turbine using MAGLEV Technology

Pallavi Deshmukh¹, Komal Gargelwar², Komal Jadhav³, Poonam Vankudre⁴, Prof. Sachin Dattey⁵

^{1,2,3,4} Student in Electrical Department, SKN Sinhgad Institute of Technology and Science, Lonavala, Maharashtra, India

⁵H.O.D. in Electrical Department, SKN Sinhgad Institute of Technology and Science, Lonavala, Maharashtra, India

Abstract- This paper displays an overview of the maglev wind turbine configuration highlights. A vertical axis wind turbine (VAWT) is acquainted by magnetic levitation innovation to enhance the execution. The system use nature of permanent magnet to suspend the turbine part and thus minimize energy losses while rotating, which is the real issue that confronted by conventional wind turbine. The choice of magnet materials in the outline of wind turbine system will be discussed. The electricity producing capacity in wind turbines is impacted by the mechanical measurements of the blade including the shape of the blade and the angle of attack. The Proper outline of the blade shape and position tends to improvise the productivity even at low wind speed. The horizontal of impact at angle of 300 is found to have the highest lift coefficient for the selected air foil structure. The utilization of MAGLEV concept in the VAWT diminishes the vibration by 37.5%. Test results are given with and without MAGLEV imported to the VAWT design. Additionally it is measured that the electricity produced with maglev system is increment by 12% contrast with the typical wind turbine.

Key words: VAWT, Maglev, Blade design, blade position

1.INTRODUCTION

Human have developed a huge number of machines and apparatuses that use energy to make the everyday works simpler, for example to warm our home, to get ourselves from place to place. Recently, the wind is harnessed by utilizing a unique collector, called wind turbine to deliver a

perfect, safe wellspring of electricity. Different design have been proposed keeping in mind the end goal to make a highly effective wind turbine which is capable of generating maximum electric power. Adopting a specific innovation for horizontal wind turbine is challenging with wind quality in Malaysia yearly around 2-3m/s with most highest being 7m/s at Mersing is quite challenging. As of late, an advance procedure, Magnetic Levitation (Maglev) is incorporated into turbine system with a specific end goal to satisfy the necessities of those energy industries. The Maglev wind turbine, which was initially divulged at the Asia display in Beijing, is expected to take wind power technology to the next horizontal with magnetic levitation. Magnetically levitated train constitutes one of the significant Progress made because of Maglev technologies. The Japan's Maglev train has set up world record train speeds of 581 Km/h in 2003 and 603 km/h in 2014. Essentially, vertical axis Wind turbine (VAWT) utilizing magnetic bearing can begin producing power with wind speeds as low as 1.5 m/s. The constraint is on the utilization of horizontal wind turbine is less critical as it requires wind speed of around 8-15m/s. On opposite vertical axis wind turbine generates electricity even at low wind speed, generally where the required output power is smaller. Experimental consequences of Maglev (VAWT) demonstrate that system vibration can be lessened by 37.5%, and power generating capacity of the system is expanded by 12% utilizing Maglev concept.

2. LITERATURE SURVEY

2.1 Wind Energy

Wind is the streaming of air. This wonder happens in the entire world and it is brought about by uneven warming on the earth's surfaces which causes the air to spill out of more smoking districts with higher pressure to colder locales with lower pressure. There are a few motivations to bolster in utilizing the wind energy to create electricity control. Wind control accessible in the air is much more prominent than current world energy utilization. The abuse of wind electricity is just constrained by the financial and natural variables, since the asset accessible is far bigger than any reasonable intends to create it. Renewable energy created from the wind has pulled in a great deal of consideration and support in late year's. Be that as it may, this environmentally friendly electricity energy is frequently condemned for its low yield and absence of unwavering quality.

2.2 Wind Turbine

The fundamental working standard of a wind turbine is: When air move rapidly, as wind, and their dynamic energy is caught by the turbine sharp blade. The blade begin to turn and turn a shaft that leads from the center point of the rotor to a generator and create electricity. The convention generator encounter bunches of issue, for example, very wasteful, costly, high support cost, dangerous to natural life, and take up an excess of land, require high beginning wind speed to work. When all is said in done, they are two sorts of wind turbine as per the hub they are rotating about. Horizontal Axis wind turbine (HAWT) is the kind of wind turbine which has a fundamental rotor shaft and electrical generator at the highest point of tower and indicated the bearing of wind.. With respect to the Vertical Axis wind turbine (VAWT) comprises of generator and gearbox which are set at the ground and subsequently there is no requirement for a tower to bolster them as in HAWT. The principle rotor shaft is masterminded vertically to permit

the turbine sharp blade turn without confronting to the heading of the wind. In VAWT framework, the generator and gearbox is put on the ground as opposed to on the top. The machine require fellow wires to hold it set up puts pressure on the base bearing as all the heaviness of the rotor is on the bearing. Fellow wires joined to the top bearing increment descending push in wind blasts. Tackling this issue requires a superstructure to hold a top bearing set up to wipe out the descending pushes of blast occasions in fellow wired models.

2.3 Magnetic Levitation

Magnetic levitation (maglev) is a strategy in which a object is suspended with no bolster other than magnetic. The magnetic delivered is utilized to balance the impacts of the gravitational force and lift up the object. There are many points of interest for using magnetic levitation that is to minimize friction, make force measurement, outline, and entertaining gadgets. As of late, this propel innovation is connected into transportation framework in which non reaching vehicle travel securely at rapid while suspended, guided, and impelled over a guide path by magnetic fields. The idea of magnetically suspended vehicle invigorates the improvement of helpful application in different fields, for example, the electricity generation.

2.4 Maglev Wind Turbine

Dissimilar to the maglev vehicle, the vertically oriented blade of the wind turbine are suspended noticeable all around over the base of the machine by utilizing permanent magnet which produces magnetic force to lift up the sharp blade. This framework does not require the electricity to work in light of the fact that no electromagnets are included. Since the turbine blade are suspended by magnetic force deliver by the permanent magnet, there is no need of ball bearings to hold the sharp blade. This permits the erosion between the sharp blade and ball bearings can be lessened altogether and consequently,

minimizes the energy loss. This additionally diminishes upkeep expenses and builds the life expectancy of the generator. The Maglev wind turbine, which was initially revealed at the Wind power Asia display in Beijing, is normal take wind control innovation to the following horizontal with magnetic levitation.

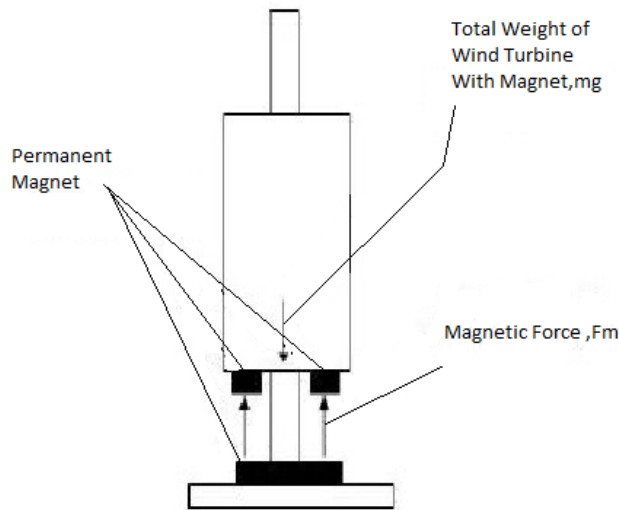

Figure 1: Free body diagram of magnetically levitated object

3.METHODOLOGY

3.1Construction

The structure of VAWT is that the rotor rotates the shaft where the shaft is associated with a generator. This implies there is no heavy nacelle or yaw system required. This ideal wind turbine is frictionless and does not have any rotational component of velocity in the wake.

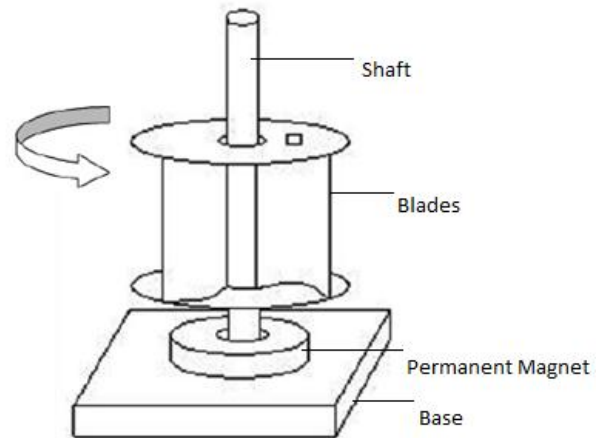

Figure 2: Maglev Wind Turbine Model

3.2Working

A Maglev wind turbine or Maglev windmill would utilize magnetic levitation to replace conventional bearing in design of wind turbine. A late outline was created in china by Guangzhou Energy Research Institute under china's Academy of sciences and by Guangzhou Zhongke Hengyuan Energy Science and Technology co., Ltd.

The design claims to use winds with beginning speed as low as 1.5 meters for every second (m/s), and cut in speed of 3 m/s. This could include 1,000 hours of operation every year to wind power plants in areas with a normal wind speed of 3 m/s. However since the energy accessible in wind changes as the third force of wind speed, the electricity created at such speeds would be lower than ordinary wind turbine under higher speed winds.

The rotating turbine shaft is bolstered by magnetic levitation rather than ball bearings. Magnetic bearing have been utilized for littler turbines and pumps, however they by and large can't deal with effect disturbing the shaft, and by and large requires effectively controlled electromagnets. Making magnetic heading sufficiently solid to handle load of wind turbine would utilize restrictive measure of force simply keeping the electromagnet running. The chines configuration is said to utilize permanent magnets to support the rotor shaft.

3.4 Mathematical Expressions

The amount of power P_0 that can be generated by the wind turbine is given as in Equation (1)

$$P_0 = \frac{1}{2} \rho A u^3 C_p \quad (1)$$

Where ρ air density [kg/m^3] which is $1.225 \text{ kg}/\text{m}^3$, A is Turbine blade area [m^2] C_p is power coefficient, u is the wind Speed [m/s].

Once the wind speed set, the Tip Speed ratio (TSR) is computed. The TSR (λ) of the blade is given as in Equation (2)

$$\lambda = \omega R / u \quad (2)$$

Where ω is the rotational speed of rotor, R is the radius tip of motor. The decision on the selection of the λ relies on both the wind speed and the generator.

There are three different types of blade shapes namely NACA0012, NACA4212 and NACA8612 are used for the analysis for the design of VAWT [8].

The lift produced by the air foil is given as in Equation (3)

$$L = \frac{1}{2} \rho u^3 A_b C_L \quad (3)$$

where C_L is the lift coefficient, ρ is air density [kg/m^3], A_b is the area of blade [m^2], and u is wind speed [m/s].

$$A_b = 2RH \quad (4)$$

where R is the radius of the turbine [m] and H is the height of the turbine [m]. It is seen that the height and the radius of the

rotor affects the lift force of the blade. High solidity will increase its performance but too high of solidity will decrease the power coefficient and is given as in Equation (5)

$$\sigma = NCL/S \quad (5)$$

Where N is the number of blades, C is the chord length of the Blade [m], L is the length of the rotor [m] and S is the swept Area of the rotor [m^2]. It is shown that the size and number of the blade is an important factor in solidity. For the same solidity, various number of blade and chord size will affect the execution of the VAWT

5. CONCLUSION

The Vertical Axis Wind Turbine (VAWT) with magnetic levitation performs superior to the ordinary wind turbine. The capacity of the rotor to collect more wind is broke down on the three blade design and for the blade position. Computational liquid elements based limited component approach is utilized for the investigation on the blade design and the situating of the sharp blade on the rotor.

6. REFERENCE

- [1] B. Bittumon, Amith Raju, Harish Abraham Mammen, Abhy Thamby, Aby K Abraham, "Design and Analysis of Maglev Vertical Axis Wind Turbine", International Journal of Emerging Technology and Advanced Engineering Website: www.ijetae.com (ISSN 2250-2459, ISO 9001:2008 Certified Journal, Volume 4, Issue 4, April 2014)
- [2] Aravind CV, Kamalinni, Tay SC Jagadeeswaran A, RN Firdaus, "Design Analysis of MAGLEV-VAWT with Modified Magnetic Circuit Generator", 2014 IEEE 2nd International Conference on Electrical Energy Systems (ICEES)
- [3] Gene Abbascia, Kojo Asenso, Adam White, "MAGNETICALLY LEVITATED VERTICAL-AXIS WIND TURBINE"
- [4] Ashwin P. Joseph, Suraj P. Chavhan, Pravesh K. Sahare, Abdul Arif, Tanveer A. Hussain, "Review Paper on Wind Turbine using Magnetic Levitation", IJRMET Vol. 6, Issue 1, Nov 2015-April 2016
- [5] Huachun Wu Ziyang Wang Yefa Hu, "Study on Magnetic Levitation Wind Turbine for Vertical Type and Low Wind Speed", 2010 IEEE.