

# A NOVEL FOUR WIRE INVERTER SYSTEM USING SVPWM TECHNIQUE FOR UPS APPLICATIONS

Vidhya.M<sup>1</sup>, Mohanapriya.V<sup>2</sup>

<sup>1</sup>Assistant Professor, Dept of EEE, Bannari Amman Institute of Technology, Tamilnadu, India

<sup>2</sup>Assistant Professor, Dept of EEE, Bannari Amman Institute of Technology, Tamilnadu, India.

\*\*\*

**Abstract** - This paper proposes the performance improvement of the power converters in Uninterruptible Power Supply (UPS) based on size reduction, efficiency improvement and power quality. The traditional UPS consists of step up transformer or dc-dc chopper to boost the voltage which decreases the efficiency, reduces the power quality and leads to increase the cost of energy conversion. Many PWM techniques are available for inverter switching. This paper introduces the concept of space vector modulation for four wire voltage source inverters. The Space vector modulation scheme generates the inverter leg switching time from the sampled reference phase voltage amplitudes. It involves sector identification and lookup tables. The four wire inverters are used in many applications to handle the neutral current caused by the unbalanced and non-linear load. The Space Vector Modulation (SVM) for four wire voltage source inverter is simulated using MATLAB/SIMULINK model for two level output voltages. Further the results are analyzed for various loading conditions for two level output voltage waveform.

voltage. The dc power input to the inverter may be battery, fuel cell, solar cell or other source. But in most industrial applications it is fed by a rectifier.

A voltage fed inverter (VFD) or Voltage source inverter (VSI), is one in which has stiff dc voltage source at its input terminals. In many industrial applications, it is often required to control the output voltage of the inverter to cope up with the variations of the DC input voltage, for voltage regulation of the inverters and for the constant volt /frequency control requirements [2]. In spite of the complexity involved in the SVM (many output vectors) compared to carrier-based, it remains the preferred one due to the reduced power losses by minimizing the power electronic devices switching frequency.

This paper presents the state-of-the-art of SVM technique and computer simulation works of SVM scheme in four wire voltage source inverter. It also compares the results of the two level in terms of Total harmonic distortion (THD) and loading conditions.

**Key Words:** Inverter, Space Vector Modulation, THD

## 1. INTRODUCTION

The space vector modulation (SVM) method is an advanced, computation intensive PWM method and is possibly the best among all the PWM techniques. Because of its superior performance characteristics, it has been finding wide spread application in recent years. A power electronic inverter is essentially a device for creating a variable ac frequency output from a DC input [1]. The output frequency of an inverter is determined by the rate at which the semiconductor devices are switched on and off by the inverter control circuitry and consequently, an adjustable frequency ac output is readily provided. It is possible to control the output voltage as well as optimize the harmonics by performing multiple switching within the inverter with constant dc input

## 2. FOUR WIRE VOLTAGE SOURCE INVERTER

Four wire inverter is a way of providing a neutral connection for three phase four wire unbalanced systems using a four leg inverter topology by tying the neutral point to the midpoint of the fourth neutral leg. Four leg inverter is utilized in high power UPS for its advantage of feeding unbalanced load and the higher dc voltage utilization. Conventional three phase three wire inverters are suitable for supplying three phase balanced loads. For unbalanced three phase loads these four wire inverters able to provide a path for the neutral current, flexibility to control the

neutral voltage and hence produces balanced voltage across each phase.

The two main ways for neutral wire connection are

- Inverter with split dc link capacitors
- Inverter with fourth(neutral)leg[3][4][5]
- ❖ The first way is simplest one but it generates the zero sequence harmonics and a high voltage ripple over supply capacitor is produced by neutral currents when the load is unbalanced or non-linear shown in fig 1.
- ❖ The second way requires additional power switches and quite complex control strategy. It offers different advantages, such as increased maximum output voltage value, a reduction of neutral currents and the possibility of neutral point voltage control shown in fig 2.

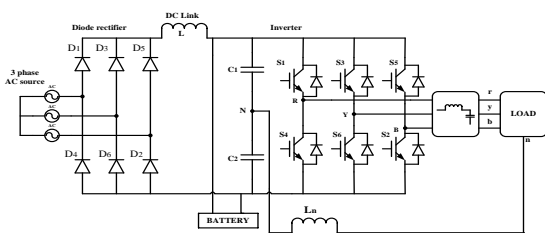

**Fig -1:** Circuit diagram of three phase four wire inverter

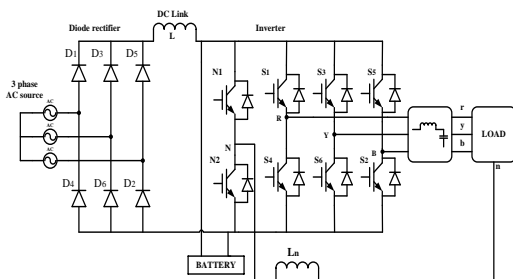

**Fig -2:** Circuit diagram of three phase four leg inverter

In four leg inverters the load neutral wire is connected to the fourth leg as shown in Fig 2. This provides the flexibility to control the neutral voltage and hence produces balanced voltage across each phase is  $V_{dc}$ . The two additional power switches in four wire doubles the number of inverter output states from  $8(=2^3)$  to  $16(=2^4)$ . This improves the

quality output waveform. There are sixteen switch combinations possible in four leg inverters. The switching vectors are represented by states  $[S_n, S_r, S_y, S_b]$  of the inverter legs. There are 14 non-zero voltage vectors and two zero vectors  $(1111), (0000)$ . The three phase variables  $K_r, K_y$  and  $K_b$  can be transferred as orthogonal coordinates  $K_\alpha, K_\beta, K_\gamma$  using eqn (1). Any three phase sinusoidal set of quantities can be transformed to an orthogonal reference.

$$\begin{pmatrix} K_\alpha \\ K_\beta \\ K_\gamma \end{pmatrix} = \frac{2}{3} \begin{bmatrix} \cos\theta & \cos(\theta-2\pi/3) & \cos(\theta-4\pi/3) \\ \sin\theta & \sin(\theta-2\pi/3) & \sin(\theta-4\pi/3) \\ 1/2 & 1/2 & 1/2 \end{bmatrix} \begin{bmatrix} K_r \\ K_y \\ K_b \end{bmatrix} \dots (1)$$

Where  $\theta$  is the angle of orthogonal set  $\alpha-\beta-\gamma$  with respect to arbitrary reference. If  $\alpha-\beta-\gamma$  axes are stationary and the  $\alpha$ -axis is aligned, then  $\theta=0$  at all times. Thus, we get

$$\begin{bmatrix} K_\alpha \\ K_\beta \\ K_\gamma \end{bmatrix} = \frac{2}{3} \begin{bmatrix} 1 & -\frac{1}{2} & -\frac{1}{2} \\ 0 & \frac{\sqrt{3}}{2} & -\frac{\sqrt{3}}{2} \\ \frac{1}{2} & \frac{1}{2} & \frac{1}{2} \end{bmatrix} \begin{bmatrix} K_r \\ K_y \\ K_b \end{bmatrix} \dots (2)$$

The above matrix can be re-written as

$$K_\alpha = \frac{1}{3} (2K_r - K_y - K_b) \dots (3)$$

$$K_\beta = \frac{1}{\sqrt{3}} (K_y - K_b) \dots (4)$$

$$K_\gamma = \frac{1}{3} (K_r + K_y + K_b) \dots (5)$$

When the leg is denoted by 1 the upper switch is closed when the leg is 0 the lower switch of the leg is closed. The switch positions determine the phase to neutral voltages, which are transformed to  $\alpha-\beta-\gamma$  coordinates. Table I shows the phase to neutral voltages and transformed  $\alpha-\beta-\gamma$  voltages for each inverter switching state.

**Table-1:** Switching Combination And Output Voltages For 4-Wire 3 Phase Inverter

SWITCH ING STATES	$V_{rn}$	$V_{yn}$	$V_{bn}$	$V_\alpha$	$V_\beta$	$V_\gamma$
0000	0	0	0	0	0	0

0001	0	0	V <sub>dc</sub>	-1/3V <sub>dc</sub>	-1/√3V <sub>dc</sub>	1/3V <sub>dc</sub>
0010	0	V <sub>dc</sub>	0	-1/3V <sub>dc</sub>	1/√3V <sub>dc</sub>	1/3V <sub>dc</sub>
0011	0	V <sub>dc</sub>	V <sub>dc</sub>	-2/3V <sub>dc</sub>	0	2/3V <sub>dc</sub>
0100	V <sub>dc</sub>	0	0	2/3V <sub>dc</sub>	0	1/3V <sub>dc</sub>
0101	V <sub>dc</sub>	0	V <sub>dc</sub>	1/3V <sub>dc</sub>	-1/√3V <sub>dc</sub>	2/3V <sub>dc</sub>
0110	V <sub>dc</sub>	V <sub>dc</sub>	0	1/3V <sub>dc</sub>	1/√3V <sub>dc</sub>	2/3V <sub>dc</sub>
0111	V <sub>dc</sub>	V <sub>dc</sub>	V <sub>dc</sub>	0	0	V <sub>dc</sub>
1000	-V <sub>dc</sub>	-V <sub>dc</sub>	-V <sub>dc</sub>	0	0	-V <sub>dc</sub>
1001	-V <sub>dc</sub>	-V <sub>dc</sub>	0	-1/3V <sub>dc</sub>	-1/√3V <sub>dc</sub>	-2/3V <sub>dc</sub>
1010	-V <sub>dc</sub>	0	-V <sub>dc</sub>	-1/3V <sub>dc</sub>	1/√3V <sub>dc</sub>	-2/3V <sub>dc</sub>
1011	-V <sub>dc</sub>	0	0	-2/3V <sub>dc</sub>	0	-1/3V <sub>dc</sub>
1100	0	-V <sub>dc</sub>	-V <sub>dc</sub>	2/3V <sub>dc</sub>	0	-2/3V <sub>dc</sub>
1101	0	-V <sub>dc</sub>	0	1/3V <sub>dc</sub>	-1/√3V <sub>dc</sub>	-1/3V <sub>dc</sub>
1110	0	0	-V <sub>dc</sub>	1/3V <sub>dc</sub>	1/√3V <sub>dc</sub>	-1/3V <sub>dc</sub>
1111	0	0	0	0	0	0

### 3. SPACE VECTOR MODULATION

A different approach to PWM is based on the space vector representation of the voltages in the d-q plane. The technique of space vector modulation involves the concept of space vector [6]. In any three phase machine, the stator coils are distributed in space in a symmetrical manner i.e. each coil is placed at 120 degree with respect to each other. In this method the three phase quantities can be transformed to their equivalent 2-phase quantity either in synchronously rotating frame or stationary reference frames

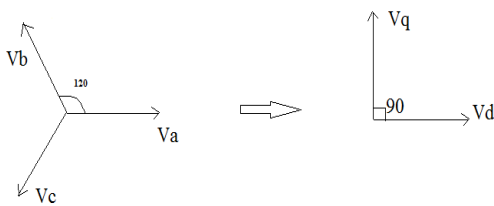

**Fig -3:** Three Phase Quantities Transformed to Two Phase

From this 2 Phase component the reference vector magnitude can be found and used for modulating the inverter output. Let the three phase sinusoidal voltage component be,

$$V_a = V_m \sin \omega t$$

$$V_b = V_m \sin (\omega t - 120)$$

$$V_c = V_m \sin (\omega t + 120)$$

Equating the three phase machine quantities, we get

$$V_a + V_b + V_c = 0 \quad \dots (6)$$

$$V_d = -3/2(V_b) + 3/2(V_c) = 3/2 V_m \cos \omega t \quad \dots (7)$$

$$V_q = V_a - V_b/2 - V_c/2 = 3/2 V_m \sin \omega t. \quad \dots (8)$$

$$\text{Rotating vector, } V_{ref} = V_d = V_q = 3/2 e^{j\omega t} \quad \dots (9)$$

From equation (9) it can be seen that the space vector moves with a constant angular velocity and constant amplitude. In case of non sinusoidal quantities, the space vectors will not necessarily move with constant amplitude or constant angular velocity. The output of the inverters which are usually used in various applications are not perfectly sinusoidal. It contains appreciable amount of harmonics. So, the space vector of the stator voltages in these cases is of amplitude V<sub>dc</sub> moving in steps and not with a constant angular velocity. In space vector modulation, a reference vector of the stator voltages is generated, which is made to move in the d-q plane in small steps so that it appears to move smoothly, as in the case with a sinusoidal supply.

The space vector modulation is based on the space vector representation of voltages in d-q plane. After the transformation to the two phase quantities, the power as well as the impedance remains unchanged. In space vector modulation we try to generate a voltage reference vector at any point of time and the voltage reference vector  $V_{ref}$  is sampled which is approximated by a time sequence of three well defined switching state vector nearest to the reference vector. This is done by sampling the switching state vectors in such a way that the total volt seconds generated by these vectors over an interval  $T_s$  equals the volt seconds generated by the reference vector  $T_s$ .

The space vector modulation technique is a PWM technique that is relatively recent. It is amenable to digital implementation. This method has the advantage that it yields a higher value of

fundamental voltage as compared to the other PWM techniques. As a result, it produces less harmonic distortion in the critical range where the ratio of switching frequency to fundamental frequency is low. It is possible to implement this technique in a simple manner and with a variety of switching devices. This method can also be used for high switching frequency. The space vector modulation technique differs from other SPWM technique in that there are not separate modulators used for each of the three phases. Instead, the complex reference voltage is processed as a whole.

The space vector concept is used for deriving the switching instants for a two level PWM inverters. The PWM control is performed according to the space vector modulation technique. The controlling variables of a space vector modulator are the components of the stator voltage vector, referred to as the reference vector  $V_{ref}$  in polar coordinates. The space vector modulation strategy approximates the reference vector during a sampling interval by a sequence of three nearest switching state vectors.

The circuit of a three phase bridge inverter consists of three half-bridges, which are mutually phase shifted by  $2\pi/3$  angle to generate a three phase voltage waves.

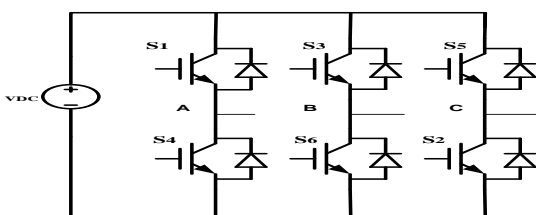

Fig -4: Simplified Two Level Inverter

Consider the simplified three phase inverter in the figure (4). At any time only one switch in each leg of the inverter is on. When the top of any leg of the inverter is turned on .The voltage at the midpoint of that leg with respect to the dc centre tap is  $V_{dc}/2$ .Let the former state be represented by +, the latter

state by-

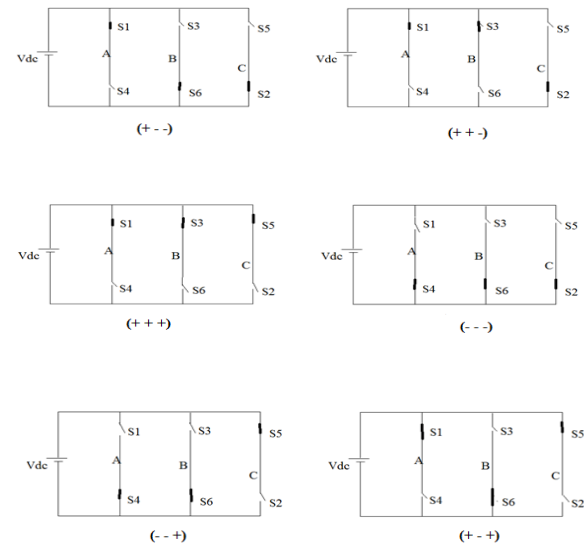

Fig -5: Inverter Switching States

There are 8 possible states with the inverter. The line-line stator voltage will be:

$V_{ab}=V_{a0}-V_{b0}, V_{bc}=V_{b0}-V_{c0}, V_{ca}=V_{c0}-V_{a0}$ .The line to neutral voltages are  $V_{an}=1/3(V_{ab}-V_{ca}), V_{bn}=1/3(V_{bc}-V_{ab}), V_{cn}=1/3(V_{ca}-V_{bc})$ . The phasors for each state of inverter also called the switching state vectors can be drawn as shown in figure (6). The vector of the inverter output voltage  $V_k$  can assume only seven different locations in the complex plane which are called the switching state vectors [7].

$$V_k = \{(2/3) V_{dc} e^{(k\pi/3)} \quad k=1, 2, \dots$$

$$\{0 \quad k=0$$

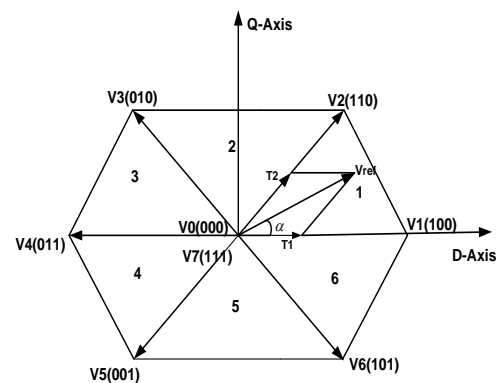

**Fig -6:** Space Vector Representation of Two Level Inverter

In the space vector modulation, the space phasor of the stator voltage is approximated by a reference phasor  $V_{ref}$  which moves in the dq plane with smooth motion as in the case when a balanced three voltage is supplied to the stator. This is achieved by sampling the switching state vector in such a way that the time average over a sampling interval  $T_s$  equals the time average of  $V_{ref}$  over  $T_s$ . Consider a 60 degree sector figure(7)described by a successive switching state vectors and two zero state vectors.

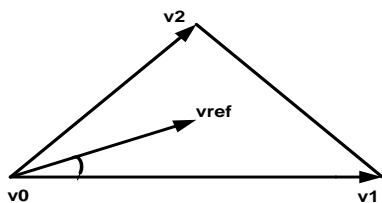

**Fig 7:** Determination of Switching States

The sampling time,  $T_s = 1/f_s$ , where  $f_s =$  switching frequency. The switching state vector  $V_1$  is sampled for time  $T_1$ ,  $V_2$  for time  $T_2$  and  $V_0$  and  $V_7$  for time  $T_0/2$  each such that

$$V_{ref} \cdot T_s = V_0 \cdot T_0/2 + V_7 \cdot T_0/2 + V_1 \cdot T_1 + V_2 \cdot T_2 \quad (10)$$

$$T_s = T_0 + T_1 + T_2 \quad \dots (11)$$

From equations (10) and (11)  $T_1$  and  $T_2$  and  $T_0$  can be obtained. Considering the projection of  $V_1$ ,  $V_2$  and  $V_{ref}$  on dq axis  $T_1 = T_s \cdot m \cdot \sin(60 - \gamma)$ ,  $T_2 = T_s \cdot m \cdot \sin(\gamma)$ ,  $T_0 = T_s - (T_1 + T_2)$  where  $m = V_{ref}/V_{dc}$ , the modulation index and  $V_1 + V_2 + V_{dc}$ . The implementation of SVM involves generation of the gating pulses to each of the six devices of the inverter for the correct intervals so that the appropriate time intervals given by the three equations. Based on the sector in which the reference vector is present at any sampling interval,  $V_1$  and  $V_2$  may be any of the six switching state vectors.  $V_1$  is active for time  $T_1$ ,  $V_2$  for  $T_2$  and  $V_0$  and  $V_7$  for  $T_0/2$  each.

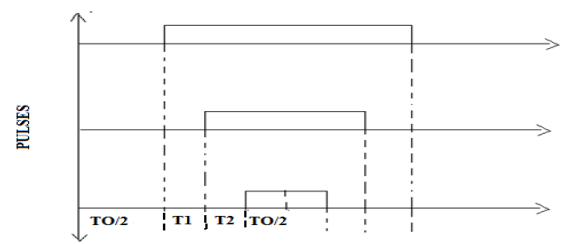
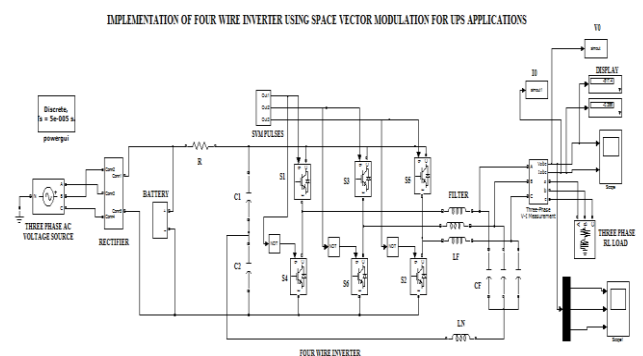

**Fig -8:** Optimum Pulse Pattern of Space Vector PWM

During the sampling interval the desired reference vector is approximated in an average sense, and not the same as reference vector. So there is a voltage ripple. The ripple and there by the harmonic current can be reduced to some extent by switching as mentioned above. Also, by keeping the sampling frequency very high compared to supply frequency, the ripple current can be reduced. The vector PWM gives a higher voltage output while still in modulation, by a factor of 2/3 or 15% more output without going to over modulation. The optimum PWM modulation is possible if only the three switching states adjacent to the reference vector are used and the cycle wherein the average voltage vector becomes equal to the reference vector consists of three successive switching states only.

#### 4. SIMULINK IMPLEMENTATION

The proposed three phase four wire inverter is tested on online UPS system simulated using Matlab/Simulink implementation. The Fig (9) shows the open loop circuit of the 4 wire inverter. Here a LC filter is connected in the output side to get a pure sinusoidal waveform and to reduce harmonics. Neutral inductance can reduce the current flowing through the neutral leg.



**Fig -9:** Simulink Implementation of SVM based Two Level Inverter

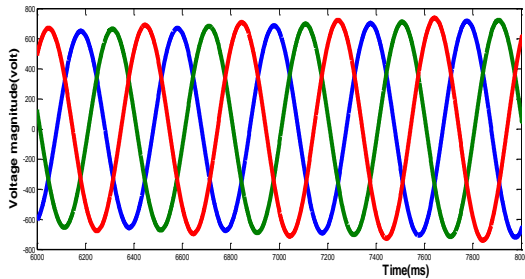

**Fig.10:** Output Phase Voltage at switching frequency 7200HZ, at 250W

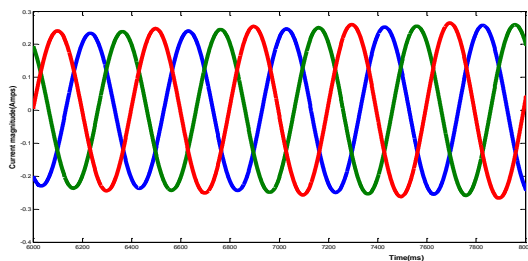

**Fig.11:** Output Phase Current at switching frequency 7200HZ, at 250W

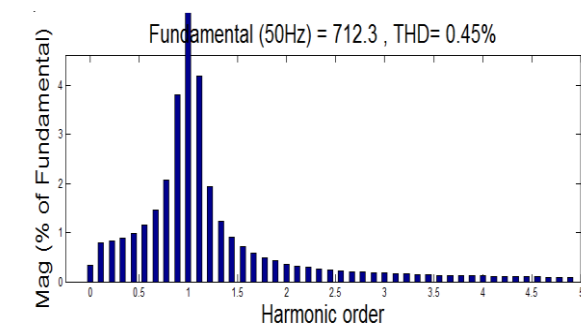

**Fig.12:** Total Harmonic Distortion of Phase Voltage at Switching Frequency=7200HZ, MI=0.87 at 250W

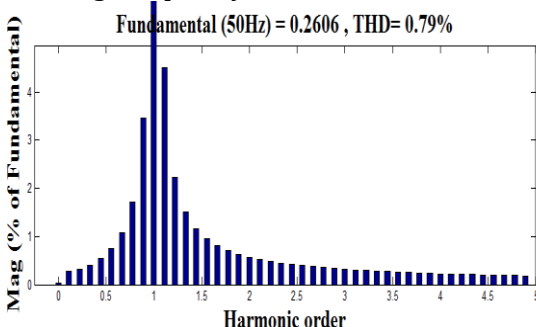

**Fig.13:** Total Harmonic Distortion of Phase Current at Switching Frequency=7200HZ, MI=0.87 at 250W

**Table -2:** measurement of various parameters for different loading conditions

INPUT VOLTAGE (V)	LOAD (kW)	OUTPUT VOLTAGE (V)	OUTPUT THD (%)	
			VOLTAGE	CURRENT
415	0.25	600	0.45	0.79
415	0.5	600	0.42	0.76
415	0.75	600	0.39	0.73
415	1.0	600	0.36	0.70
415	1.5	600	0.26	0.58

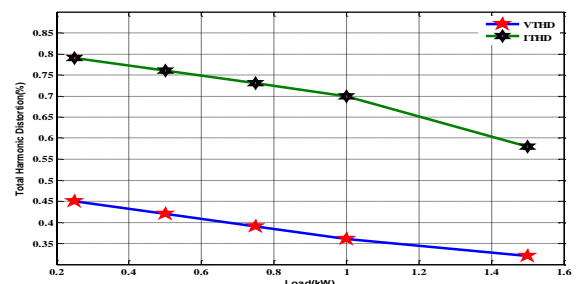

**Fig.14:** Load vs Voltage and Current THD

### 5.HARDWARE RESULTS

The three phase output voltage waveforms are phase shifted by 120° and have a magnitude of 60V (pk-pk),RMS voltage of 17.5v.

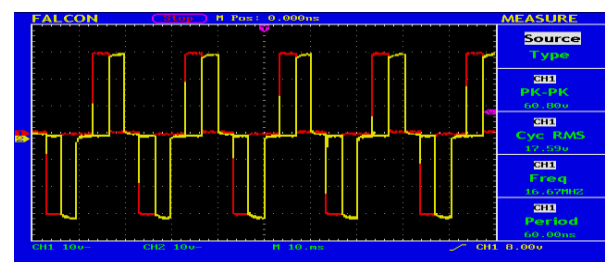

**Fig-15:** Hardware Output for line(R-Y) Voltages without filter

### 6. CONCLUSION

The Space Vector Modulation scheme is easy to implement using digital techniques. This four wire

inverter is tested using MATLAB/SIMULINK software. The performance of the two-level inverter was analyzed. It shows that as the load, switching frequency and modulation index increases THD decreases. The four-leg converter has advantage to compensation for neutral current, since it compensates neutral current directly. The fourth leg of the topology makes the inverter have the ability of handling unbalanced loads. The inductor of the fourth leg weakens the ability to handle unbalance loads, but it is necessary for the purpose of dramatically reducing the current through the fourth leg.

Four wire inverter over comes the Power quality issues during unbalanced load conditions. The proposed scheme has got the advantage of reduction in the device switching frequency for the same sampling rate which is essential when working with low frequency high power devices like GTOs.

## REFERENCES

- [1]Muhammad H Rashid, "Power Electronics, Circuits, Devices and Applications".
- [2]Bimal.K.Bose,"Modern Power Electronics and AC Drives".
- [3]Armando Bellini and Stefano Bifaretti "Modulation Techniques for Three-Phase Four-Leg Inverters" Proceedings of the 6th WSEAS International Conference on Power Systems, Lisbon, Portugal, September 22-24, 2006.
- [4]Richard Zhang, V. Himamshu Prasad, Dushan Boroyevich and Fred C.Le "Three-Dimensional space Vector Modulation for Four -Leg Voltage-Source Converters" IEEE Trans Power Electron, vol.17, no.3,May 2002.
- [5]Salem M. Ali Marian and P. Kazmierkowski "PWM Voltage and Current Control of Four-Leg VSI" IEEE 1998
- [6]Analysis and Realization of a Pulse width Modulator Based on Voltage Space VectorsHenz Willi Van Broeck, Hans-Christoph Skudelny, IEEE Transaction on Industrial Applications, vol24, no.1, January 1988
- [7]H Pinheiro,F Botteron,C Rech,L Shuch,R F Camarg,H A Grundling, J R Pinherio, "Space Vector Modulation for

Voltage Source Inverter: A unified Approach, IEEE Annual Conference ,vol.1, pp 23-29, 2002

[8]Alexandru Savulescu, "The Analysis and Simulation of the SVM Generator used for the Control of Electric Drives with Asynchronous Motors", 6 th International Conference on Electromechanical and Power Systems, October 2007