

Sag/Swell Compensation by using BES DVR in Industrial Drives Applications

R.VENKATA NARESH¹, S.V.SATYANARAYANA², P.V.RAMANJANEYULU³

¹Assistant Professor, Dept.of Electrical Engineering, Rise Krishna Sai Prakasam Group of Institutions, A.P, INDIA

² Assistant Professor, Dept.of Electrical Engineering, Rise Krishna Sai Prakasam Group of Institutions, A.P, INDIA

³Assistant Professor, Dept.of Electrical Engineering, Rise Krishna Sai Prakasam Group of Institutions, A.P, INDIA

Abstract - Power quality is one of the major concerns in the present power system environment. The situations like-voltage dip/sag, swells, harmonic content and so on, and its major effect on greatly susceptible loads are well known. To face these situations, custom power devices are utilized. Sensitive load has a severe impact on itself due to voltage sag and swell. Dynamic Voltage Restorer (DVR) is a power custom device used in power distribution network. The Dynamic Voltage Restorer (DVR) is fast, flexible and efficient solution to voltage sag problem. The important parts of the DVR comprise of voltage source inverter (VSI), booster transformers, filter and a dc energy source. The principle of the DVR is utilized to inject the voltage in series and in synchronism with the standard voltages with a goal to compensate voltage influences. In this paper, different voltage injection schemes for dynamic voltage restorers (DVRs) are analyzed with particular focus on a new method used to minimize the rating of the voltage source converter (VSC) used in DVR. A new control technique is proposed to control the capacitor-supported DVR. The control of a DVR is demonstrated with a reduced-rating VSC. The reference load voltage is estimated using the unit vectors. The synchronous reference frame theory is used for the conversion of voltages from rotating vectors to the stationary frame. The compensation of the voltage sag, swell, and harmonics is demonstrated using a reduced-rating DVR.

Key Words: Dynamic voltage restorer (DVR), power quality, unit vector, voltage harmonics, voltage sag, voltage swell.

1.INTRODUCTION

Power distribution systems, ideally, should provide their customers with an uninterrupted flow of energy at smooth sinusoidal voltage at the contracted magnitude level and frequency however, in practice, power systems, especially the distribution systems, have numerous nonlinear loads, which significantly affect the quality of power supplies. As a result of the nonlinear loads, the purity of the waveform of supplies is lost. This ends up producing many power quality problems. Apart from nonlinear loads, some system events, both usual (e.g. capacitor switching, motor starting) and unusual (e.g. faults) could also inflict power quality problems. Power quality phenomenon or

power quality disturbance can be defined as the deviation of the voltage and the current from its ideal waveform. Faults at either the transmission or distribution level may cause voltage sag or swell in the entire system or a large part of it. Also, under heavy load conditions, a significant voltage drop may occur in the system. Voltage sag and swell can cause sensitive equipment to fail, shutdown and create a large current unbalance. These effects can incur a lot of expensive from the customer and cause equipment damage. The voltage dip magnitude is ranged from 10% to 90% of nominal voltage and with duration from half a cycle to 1 min and swell is defined as an increase in rms voltage or current at the power frequency for durations from 0.5 cycles to 1 min. Typical magnitudes are between 1.1 and 1.8 p.u.

There are many different methods to mitigate voltage sags and swells, but the use of a custom power device is considered to be the most efficient method, e.g. FACTS for transmission systems which improve the power transfer capabilities and stability margins. The term custom power pertains to the use of power electronics controller in a distribution system, especially, to deal with various power quality problems. Custom power assures customers to get pre-specified quality and reliability of supply. This pre-specified quality may contain a combination of specifications of the following: low phase unbalance, no power interruptions, low flicker at the load voltage, and low harmonic distortion in load voltage, magnitude and duration of over voltages and under voltages within specified limits, acceptance of fluctuations, and poor factor loads without significant effect on the terminal voltage. There are different types of Custom Power devices used in electrical network to improve power quality problems. Each of the devices has its own benefits and limitations. A few of these reasons are as follows. The SVC pre-dates the DVR, but the DVR is still preferred because the SVC has no ability to control active power flow. Another reason include that the DVR has a higher energy capacity compared to the SMES and UPS devices. Furthermore, the DVR is smaller in size and cost is less compared to the DSTATCOM and other custom power devices. Based on these reasons, it is no surprise that the DVR is widely considered as an effective custom power device in mitigating voltage sags. In addition to voltage sags and swells compensation, DVR can also add other features such as harmonics and Power Factor correction.

Compared to the other devices, the DVR is clearly considered to be one of the best economic solutions for its size and capabilities.

Many solutions and their problems using DVRs are reported, such as the voltages in a three-phase system are balanced and an energy-optimized control of DVR is discussed in [10]. Industrial examples of DVRs are given in [11], and different control methods are analyzed for different types of voltage sags in [12]–[15]. A comparison of different topologies and control methods is presented for a DVR in [17]. The design of a capacitor-supported DVR that protects sag, swell, distortion, or unbalance in the supply voltages is discussed in [19]. The performance of a DVR with the high frequency-link transformer is discussed in [20]. In this paper, the control and performance of a DVR are demonstrated with a reduced-rating voltage source converter (VSC). The synchronous reference frame (SRF) theory is used for the control of the DVR.

2. DYNAMIC VOLTAGE RESTORER (DVR)

DVR is a Custom Power Device used to eliminate supply side voltage disturbances. DVR also known as Static Series Compensator maintains the load voltage at a desired magnitude and phase by compensating the voltage sags/swells and voltage unbalances presented at the point of common coupling.

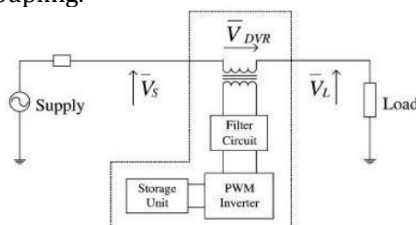

Fig-1: DVR series connected topology

The power circuit of the DVR is shown in Fig. 1. The DVR consists of 6 major parts:-

- Voltage Source Inverter (VSI):** These inverters have low voltage ratings and high current ratings as step up transformers are used to boost the injected voltage.
- Injection Transformers:** Three single phase injection transformers are connected in delta/open winding to the distribution line. These transformers can be also connected in star/open winding. The star/open winding allows injection of positive, negative and zero sequence voltages whereas delta/open winding only allows positive and negative sequence voltage injection.
- Passive Filters:** Passive filters are placed at the high voltage side of the DVR to filter the harmonics. These filters are placed at the high voltage side as placing the filters at the inverter side introduces phase angle shift which can disrupt the control algorithm.
- Energy storage:** Batteries, flywheels or SMEs can be used to provide real power for compensation. Compensation using real power is essential when large voltage sag occurs.

e) **Capacitor:** DVR has a large DC capacitor to ensure stiff DC voltage input to inverter.

f) **By-Pass Switch:** If the over current on the load side exceeds a permissible limit due to short circuit on the load or large inrush current, the DVR will be isolated from the system by using the bypass switches and supplying another path for current

3. OPERATION OF DVR

The schematic of a DVR-connected system is shown in Fig. 2(a). The voltage V_{inj} is inserted such that the load voltage V_{load} is constant in magnitude and is undistorted, although the supply voltage V_s is not constant in magnitude or is distorted. Fig. 2(b) shows the phasor diagram of different voltage injection schemes of the DVR. $V_L(\text{pre-sag})$ is a voltage across the critical load prior to the voltage sag condition. During the voltage sag, the voltage is reduced to V_s with a phase lag angle of θ . Now, the DVR injects a voltage such that the load voltage magnitude is maintained at the pre-sag condition. According to the phase angle of the load voltage, the injection of voltages can be realized in four ways [19]. V_{inj1} represents the voltage injected in-phase with the supply voltage. With the injection of V_{inj2} , the load voltage magnitude remains same but it leads V_s by a small angle. In V_{inj3} , the load voltage retains the same phase as that of the pre-sag condition, which may be an optimum angle considering the energy source [10]. V_{inj4} is the condition where the injected voltage is in quadrature with the current, and this case, is suitable for a capacitor-supported DVR as this injection involves no active power [17]. However, a minimum possible rating of the converter is achieved by V_{inj1} .

The DVR is operated in this scheme with a battery energy storage system (BESS). Fig. 3 shows a schematic of a three-phase DVR connected to restore the voltage of a three-phase critical load. A three-phase supply is connected to a critical and sensitive load through a three-phase series injection transformer. The equivalent voltage of the supply of phase A v_{sa} is connected to the point of common coupling (PCC) v_{sa} through short-circuit impedance Z_{sa} . The voltage injected by the DVR in phase A v_{ca} is such that the load voltage v_{la} is of rated magnitude and undistorted. A three-phase DVR is connected to the line to inject a voltage in series using three single-phase transformers T_r . L_r and C_r represent the filter components used to filter the ripples in the injected voltage. A three-leg VSC with insulated-gate bipolar transistors (IGBTs) is used as a DVR, and a BESS is connected to its dc bus.

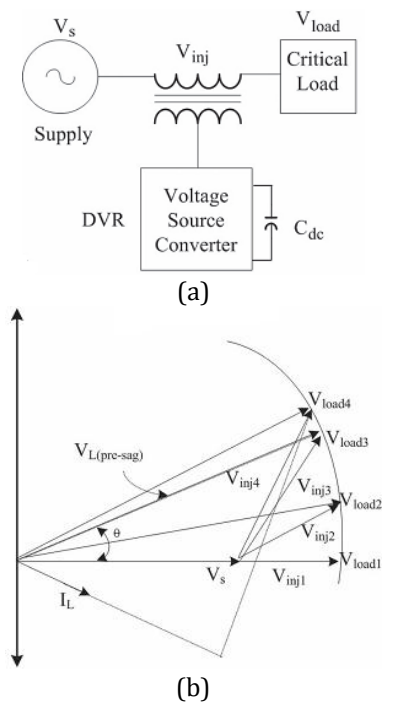

Fig-2. (a) Basic circuit of DVR. (b) Phasor diagram of the DVR voltage injection schemes.

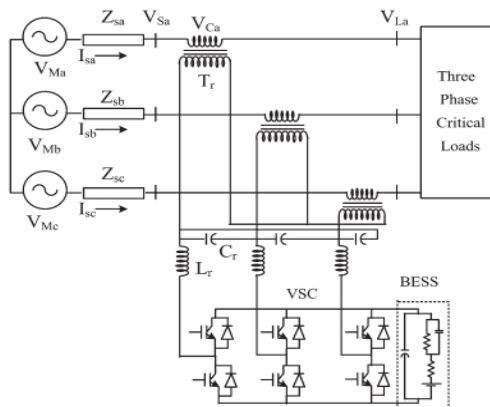

Fig-3. Schematic of the DVR-connected system

4. CONTROL OF DVR

The compensation for voltage sags using a DVR can be performed by injecting or absorbing the reactive power or the real power [17]. When the injected voltage is in quadrature with the current at the fundamental frequency, the compensation is made by injecting reactive power and the DVR is with a self-supported dc bus. However, if the injected voltage is in phase with the current, DVR injects real power, and hence, a battery is required at the dc bus of the VSC. The control technique adopted should consider the limitations such as the voltage injection capability (converter and transformer rating) and optimization of the size of energy storage.

A. Control of DVR with BESS for Voltage Sag, Swell, and Harmonics Compensation

Fig. 4 shows a control block of the DVR in which the SRF theory is used for reference signal estimation. The voltages at the PCC v_s and at the load terminal v_L are sensed for deriving the IGBTs' gate signals. The reference load voltage V^*L is extracted using the derived. Load voltages (V_{La}, V_{Lb}, V_{Lc}) are converted to the rotating reference frame using abc-dqo conversion using Park's transformation with unit vectors $(\sin, \theta, \cos, \theta)$ derived using a phase-locked loop as

$$\begin{bmatrix} v_{Lq} \\ v_{Ld} \\ v_{L0} \end{bmatrix} = \frac{2}{3} \begin{bmatrix} \cos \theta & \cos(\theta - \frac{2\pi}{3}) & \cos(\theta + \frac{2\pi}{3}) \\ \sin \theta & \sin(\theta - \frac{2\pi}{3}) & \sin(\theta + \frac{2\pi}{3}) \\ \frac{1}{2} & \frac{1}{2} & \frac{1}{2} \end{bmatrix} \begin{bmatrix} v_{Laref} \\ v_{Lbref} \\ v_{Lcref} \end{bmatrix} \quad (1)$$

Similarly, reference load voltages ($V_{La}^*, V_{Lb}^*, V_{Lc}^*$) and voltages at the PCC v_s are also converted to the rotating reference frame. Then, the DVR voltages are obtained in the rotating reference frame as

$$v_{Dd} = v_{Sd} - v_{Ld} \quad (2)$$

$$v_{Dq} = v_{Sq} - v_{Lq} \quad (3)$$

The reference DVR voltages are obtained in the rotating reference frame as

$$v_{Dd}^* = v_{Sd}^* - v_{Ld} \quad (4)$$

$$v_{Dq}^* = v_{Sq}^* - v_{Lq} \quad (5)$$

The error between the reference and actual DVR voltages in the rotating reference frame is regulated using two proportional-integral (PI) controllers. Reference DVR voltages in the abc frame are obtained from a reverse Park's transformation taking V^*Dd from (4), V^*Dq from (5), V^*D0 as zero as

$$\begin{bmatrix} v_{dvra}^* \\ v_{dvrb}^* \\ v_{dvrc}^* \end{bmatrix} = \begin{bmatrix} \cos \theta & \sin \theta & 1 \\ \cos(\theta - \frac{2\pi}{3}) & \sin(\theta - \frac{2\pi}{3}) & 1 \\ \cos(\theta + \frac{2\pi}{3}) & \sin(\theta + \frac{2\pi}{3}) & 1 \end{bmatrix} \begin{bmatrix} v_{Dq}^* \\ v_{Dd}^* \\ v_{D0}^* \end{bmatrix} \quad (6)$$

Reference DVR voltages ($v_{dvra}^*, v_{dvrb}^*, v_{dvrc}^*$) and actual DVR voltages ($v_{dvra}, v_{dvrb}, v_{dvrc}$) are used in a pulse width modulated (PWM) controller to generate gating pulses to a VSC of the DVR. The PWM controller is operated with a switching frequency of 10 kHz.

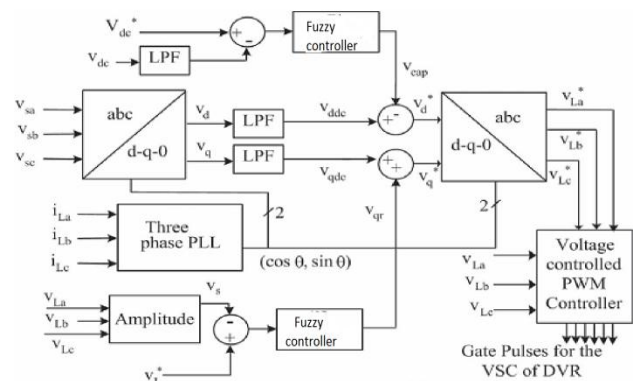

Fig - 4. Control block of the DVR that uses the SRF method of control

B. Control of Self-Supported DVR for Voltage Sag, Swell, and Harmonics Compensation

Fig 4. shows a schematic of a capacitor-supported DVR connected to three-phase critical loads, and Fig 4 shows a control block of the DVR in which the SRF theory is used for the control of self-supported DVR. Voltages at the PCC vS are converted to the rotating reference frame using abc-dqo conversion using Park's transformation. The harmonics and the oscillatory components of the voltage are eliminated using low pass filters (LPFs). The components of voltages in the d- and q-axes are

$$v_d = v_{ddc} + v_{dac} \tag{7}$$

$$v_q = v_{qdc} + v_{qac} \tag{8}$$

The compensating strategy for compensation of voltage quality problems considers that the load terminal voltage should be of rated magnitude and undistorted. In order to maintain the dc bus voltage of the self-supported capacitor, a PI controller is used at the dc bus voltage of the DVR and the output is considered as a voltage v_{cap} for meeting its losses. The referenced-axis load voltage is therefore expressed as follows:

$$v_d^* = v_{ddc} - v_{cap} \tag{9}$$

The amplitude of load terminal voltage VL is controlled to its reference voltage V_a^* using another PI controller. The output of the PI controller is considered as the reactive component of voltage v_{qr} for voltage regulation of the load terminal voltage. The amplitude of load voltage VL at the PCC is calculated from the ac voltages (v_{La}, v_{Lb}, v_{Lc}) as

$$V_L = (2/3)^{1/2} (v_{La}^2 + v_{Lb}^2 + v_{Lc}^2)^{1/2} \tag{10}$$

The reference load quadrature axis voltage is expressed as follows:

$$v_q^* = v_{qdc} + v_{qqr} \tag{11}$$

Reference load voltages ($V_{La}^*, V_{Lb}^*, V_{Lc}^*$) in the abcframe are obtained from a reverse Park's transformation as in (6). The error between sensed load voltages (v_{La}, v_{Lb}, v_{Lc}) and reference load voltages is used over a controller to generate gating pulses to the VSC of the DVR.

5. VARIABLE FREQUENCY CONTROL OF INDUCTION MOTOR

The induction motor speed variation can be easily achieved for a short range by either stator voltage control or rotor resistance control. But both of these schemes result in very low efficiencies at lower speeds. The most efficient scheme for speed control of induction motor is by varying supply frequency. This not only results in scheme with wide speed range but also improves the starting performance.

Synchronous speed of Induction Motor is directly proportional to the supply frequency. Hence, by changing the frequency, the synchronous speed and the motor speed can be controlled below and above the normal full load speed. If the machine is operating at speed below base speed, then v/f ratio is to be kept constant so that flux remains constant. This retains the torque capability of the machine at the same value. But at lower frequencies, the torque capability decrease and this drop in torque has to be compensated for increasing the applied voltage. Any reduction in the supply frequency without a change in the terminal voltage causes an increase in the air gap flux. Induction motors are designed to operate at the knee point of the magnetization characteristic to make full use of the magnetic material. Therefore the increase in flux will saturate the motor. This will increase the magnetizing current, distort the line current and voltage, increase the core loss and the stator copper loss, and produce a high pitch acoustic noise. While any increase in flux beyond rated value is undesirable from the consideration of saturation effects, a decrease in flux is also avoided to retain the torque capability of the motor. Therefore, the variable frequency control below the rated frequency is generally carried out by reducing the machine phase voltage, V, along with the frequency in such a manner that the flux is maintained constant. Above the rated frequency, the motor is operated at a constant voltage because of the limitation imposed by stator insulation or by supply voltage limitations.

6. MATLAB/SIMULINK RESULTS

Here simulation is carried out by several cases, in that 1) Voltage Sag/Swell Compensation by using Conventional DVR, 2) Voltage Sag/Swell Compensation by using Proposed DVR

Case 1: Voltage Sag/Swell Compensation by using Conventional DVR

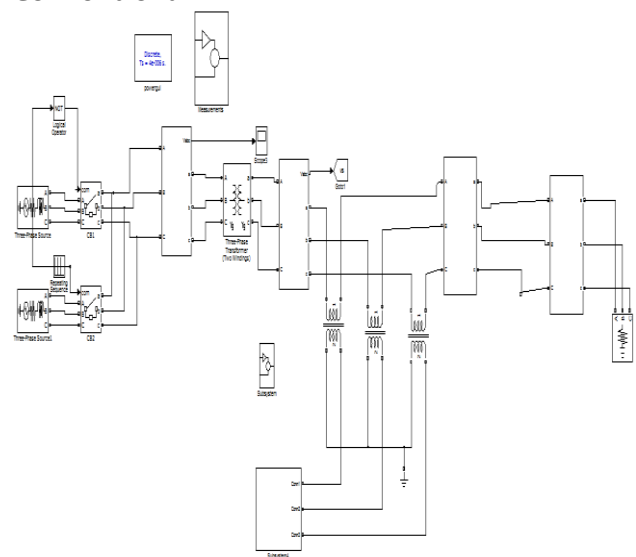
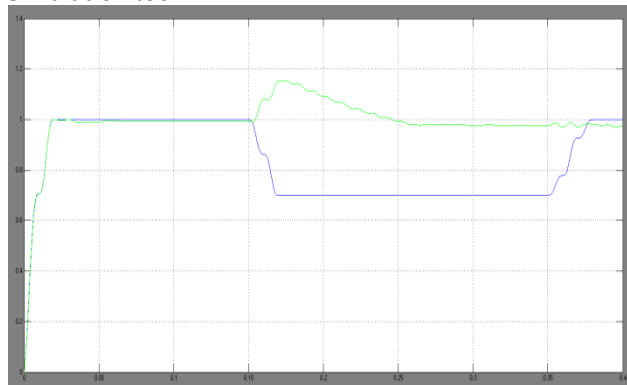
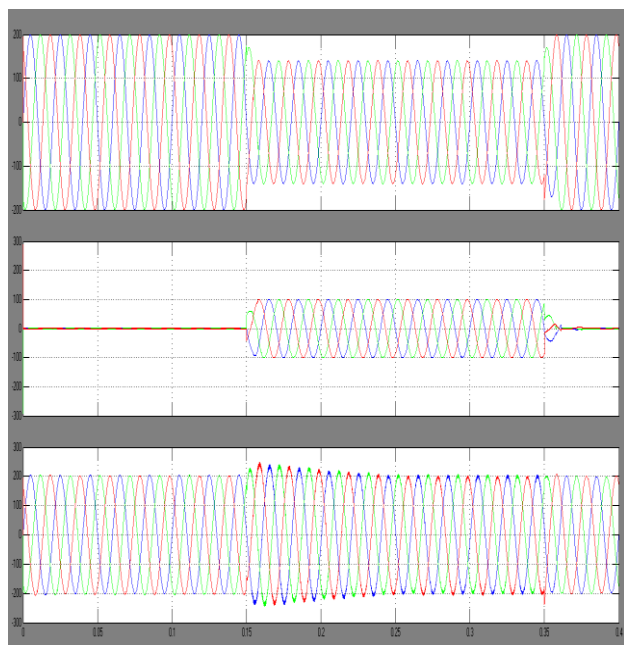

Fig -5 Matlab/Simulink Modelling of Conventional DVR under Voltage Sa/g/Swell Issues

Fig.5 shows the Matlab/Simulink Modelling of Conventional DVR under Voltage Sag/Swell Issues using computer simulation tool.



(a) RMS Value of Source & Load Voltages



(b) Source Voltage, DVR Injected Voltage, Load Voltage

Fig -6: (a) RMS values of Source & Load Voltages, (b) Source Voltage, DVR Injected Voltage, Load Voltage, of the conventional DVR under Voltage Sag Compensation Scheme.

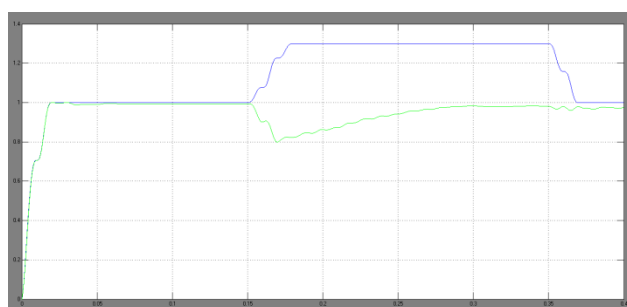

(a) RMS Value of Source & Load Voltages

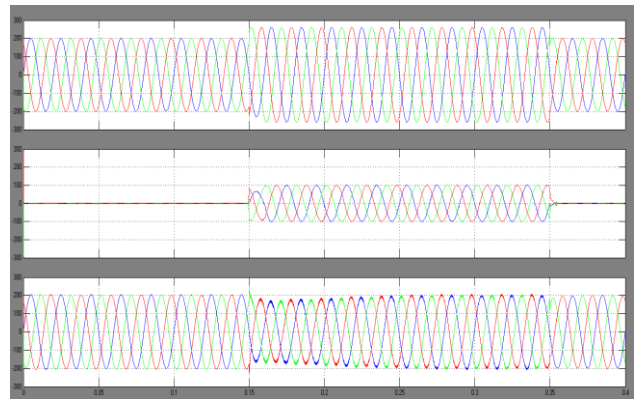

(b) Source Voltage, DVR Injected Voltage, Load Voltage

Fig -7: (a) RMS values of Source & Load Voltages, (b) Source Voltage, DVR Injected Voltage, Load Voltage, of the conventional DVR under Voltage Swell Compensation Scheme.

Case 2: Voltage Sag/Swell Compensation by using Proposed DVR using PI Controller

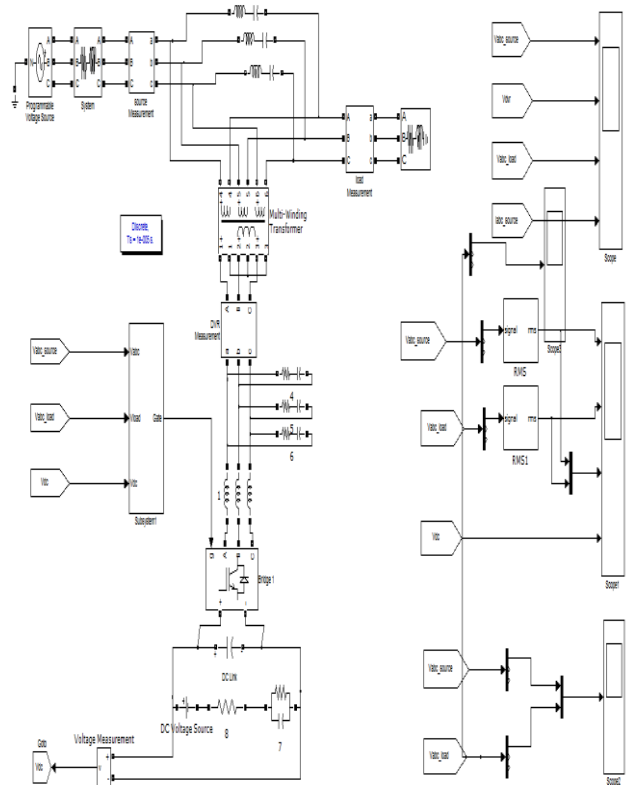

Fig -8: Matlab/Simulink Modelling of Proposed DVR under Voltage Sag/Swell Issues

Fig.8 shows the Matlab/Simulink Modelling of Proposed DVR under Voltage Sag/Swell Issues using Matlab simulation tool.

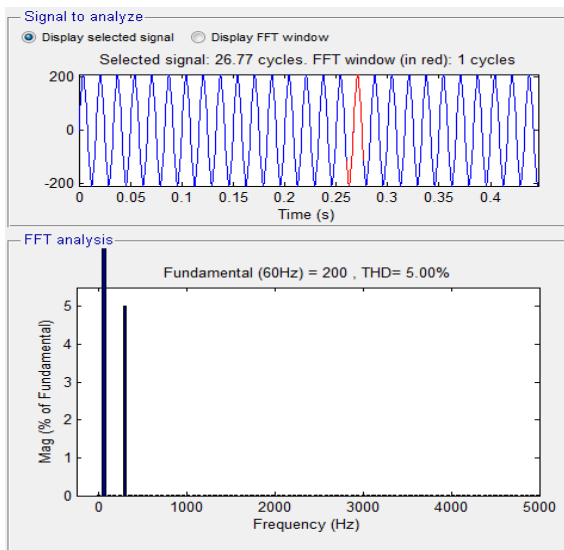

Fig-9: THD Analysis of Supply voltage

Fig.9 shows the THD Analysis of Source Voltage of the Proposed DVR under Harmonics Compensation Scheme. These harmonics are in the range of IEEE-519 standards.

7. CONCLUSION

The operation of a DVR has been demonstrated with a new control technique using various voltage injection schemes. A comparison of the performance of the DVR with different schemes has been performed with a reduced-rating VSC, including a capacitor-supported DVR. The reference load voltage has been estimated using the method of unit vectors, and the control of DVR has been achieved, which minimizes the error of voltage injection. The SRF theory has been used for estimating the reference DVR voltages. It is concluded that the voltage injection in-phase with the PCC voltage results in minimum rating of DVR but at the cost of an energy source at its dc bus.

REFERENCES

- [1] M. H. J. Bollen, *Understanding Power Quality Problems—Voltage Sags and Interruptions*. New York, NY, USA: IEEE Press, 2000.
- [2] A. Ghosh and G. Ledwich, *Power Quality Enhancement Using Custom Power Devices*. London, U.K.: Kluwer, 2002.
- [3] M. H. J. Bollen and I. Gu, *Signal Processing of Power Quality Disturbances*. Hoboken, NJ, USA: Wiley-IEEE Press, 2006.
- [4] R. C. Dugan, M. F. McGranaghan, and H. W. Beaty, *Electric Power Systems Quality*, 2nd ed. New York, NY, USA: McGraw-Hill, 2006.
- [5] A. Moreno-Munoz, *Power Quality: Mitigation Technologies in a Distributed Environment*. London, U.K.: Springer-Verlag, 2007.
- [6] K. R. Padiyar, *FACTS Controllers in Transmission and Distribution*. New Delhi, India: New Age Int., 2007.

- [7] IEEE Recommended Practices and Recommendations for Harmonics Control in Electric Power Systems, IEEE Std. 519, 1992.
- [8] V. B. Bhavraju and P. N. Enjeti, "An active line conditioner to balance voltages in a three phase system," *IEEE Trans. Ind. Appl.*, vol. 32, no. 2, pp. 287–292, Mar./Apr. 1996.
- [9] S. Middlekauff and E. Collins, "System and customer impact," *IEEE Trans. Power Del.*, vol. 13, no. 1, pp. 278–282, Jan. 1998.
- [10] M. Vilathgamuwa, R. Perera, S. Choi, and K. Tseng, "Control of energy optimized dynamic voltage restorer," in *Proc. IEEE IECON*, 1999, vol. 2, pp. 873–878.
- [11] J. G. Nielsen, F. Blaabjerg, and N. Mohan, "Control strategies for dynamic voltage restorer compensating voltage sags with phase jump," in *Proc. IEEE APEC*, 2001, vol. 2, pp. 1267–1273.
- [12] A. Ghosh and G. Ledwich, "Compensation of distribution system voltage sag using DVR," *IEEE Trans. Power Del.*, vol. 17, no. 4, pp. 1030–1036, Oct. 2002.
- [13] A. Ghosh and A. Joshi, "A new algorithm for the generation of reference voltages of a DVR using the method of instantaneous symmetrical components," *IEEE Power Eng. Rev.*, vol. 22, no. 1, pp. 63–65, Jan. 2002.
- [14] I.-Y. Chung, D.-J. Won, S.-Y. Park, S.-I. Moon, and J.-K. Park, "The DC link energy control method in dynamic voltage restorer system," *Int. J. Elect. Power Energy Syst.*, vol. 25, no. 7, pp. 525–531, Sep. 2003.
- [15] E. C. Aelofoza, P. N. Enjeti, L. A. Morán, O. C. Montero-Hernandez, and S. Kim, "Analysis and design of a new voltage sag compensator for critical loads in electrical power distribution systems," *IEEE Trans. Ind. Appl.*, vol. 39, no. 4, pp. 1143–1150, Jul./Aug. 2003.
- [16] J. W. Liu, S. S. Choi, and S. Chen, "Design of step dynamic voltage regulator for power quality enhancement," *IEEE Trans. Power Del.*, vol. 18, no. 4, pp. 1403–1409, Oct. 2003.

BIOGRAPHIES



R.VENKATA NARESH has received his B.Tech in Electrical & Electronics Engineering from JNTUK, KAKINADA in 2009 and M.Tech degree in Power system control & Automation from JNTUK, KAKINADA in 2013 respectively. He is dedicated to teaching field from the last 6 years. He has guided 24 U.G students. His research areas included FACTS controllers for power quality improvement. At present he is working as an Assistant Professor in RISE KRISHNA SAI PRKASAM GROUP OF INSTITUTIONS, Ongole, Andhra Pradesh, India.



S.V.SATYANARAYANA born in Ongole, A.P., India in the year 1989. He Received B.Tech degree in "EEE" from QIS College Of Engineering & Technology, affiliated to JNTUK, in 2010. He Received M.Tech degree in "EEE" with specialization in Power System (High Voltage) from Godavari Institute Of

Engineering & Technology,Rajahmundry affiliated to JNTUK in 2014.His Area of Interests are POWER SYSTEMS,HIGH VOLTAGE. He is a Member in IAENG ,ISRD . He Is presently working as an Assistant Professor in Electrical and Electronics Engineering Department in Rise Krishna Sai Prakasam group of Institutions, Ongole



P V RAMANJANEYULU Received his B.Tech degree in Electrical and Electronics Engineering from Rao & Naidu Engineering College, Ongole, affiliated to JNTU, Kakinada in 2011. He received his M.Tech in the department of Electrical and Electrical

Engineering with specialization in Power Electronics and Electric Drives in Gudlavalleru Engineering College, Gudlavalleru, affiliated to JNTU, Kakinada in 2015. His research interests include Power Electronic Converters, Power Quality and Drives .He is Life member in IAETSD. He Is presently working as an Assistant Professor in Electrical and Electronics Engineering Department in Rise Krishna Sai Gandhi group of Institutions, Ongole.