

A Review on Selection of Proper Busbar Arrangement for Typical Substation (Bus-Bar Scheme)

Mohit Kumar Singh¹, Chintan Jilka², Shubham Chauhan³, Kavan Dehgamwala⁴, Mr. Gaurang Patel⁵, Mr. Jignesh Joshi⁶

(^{1,2,3,4}) Student, Electrical Engineering, Shroff S.R. Rotary Institute of Chemical Technology, At & Po: vataria, Bharuch, Gujarat, India

(⁵) Sr. Engineer, Tacalkar Power Engineers & Consultants PVT. LTD (TPECPL), AT: Vadodara, Gujarat, India

(⁶) Professor, Dept. of Electrical Engineering, Shroff S.R. Rotary Institute of Chemical Technology, At & Po: vataria, Bharuch, Gujarat, India

ABSTRACT - In this study, a comprehensive review on selection and role of a bus-bar scheme and its possible extension is important initial step in substation design. The aspects which influence this decision are operational flexibility, system safety, reliability, ability to facilitate system control and cost. An important factor in selection of bus-bar scheme is the degree of reliability of supply expected during maintenance or faults. Bus-Bar arrangement nothing but a combination of Bus and Circuit Breaker.

Key Words: Busbar, Bus Layout, Switching Arrangement, Types of Busbar, Substation layout

I. INTRODUCTION

The purpose of this paper is to provide a general guide to the design and selection of proper bus bar scheme as per the design of typical substation. The present electrical power system is a complex interconnection of Generating stations-Transmission systems-Receiving stations-Distribution systems and Load points. In all the above phases of power flow, the transfer of electrical energy takes place in the electric sub stations. Basically an electrical substation consists of a number of incoming circuits and outgoing circuits connected to common bus bar systems [7].

Bus bars are conducting bars to which a number of incoming or outgoing circuits are connected and each circuit connected to the bus bar will have certain electrical component such as circuit breakers, isolators, earth switches, current transformers and voltage transformers. These components are connected in a definite sequence such that a circuit can be switched off during normal operation by manual command and also automatically during abnormal conditions such as short circuits[7].

Substation is an integral part of a power system and is an important link between the generating stations, transmission systems, distribution systems and load points, and it is designed with an objective to provide maximum reliability, flexibility, continuity of service and to meet these objectives with the lowest investment costs that satisfy system requirement. It also includes the selection of optimum voltage levels depending on the load requirements and the transmission distances involved. The system requirement must be met with minimum costs as the cost of equipment, labor, land and site treatment is increasing every day. Since the major substation costs are reflected in the power transformers, circuit breakers and disconnecting switches, the bus layout and switching arrangement selected will determine the number of switches and power circuit breakers required [2].

A number of factors must be considered in the selection of bus layouts and switching arrangements for a substation to meet system and station requirements. Due to this substation must be reliable, economical, safe, and as simple in design as possible. The layout is significant as it influences the operation, maintenance, cost and protection of the substation. These aspects are considered while designing the substation layout.

II. OVERVIEW OF BUSBAR CONFIGURATION

Now certain amount of sectionalisation has also to be provided in a substation so as to ensure that in the event of fault, a large power source does not get disconnected. In the case of step-up substations associated with large generating stations a fault within the substation may have serious repercussions from the point of view of the system operating as a whole and, therefore, a very high degree of reliability is required in such cases as compared

to step down or switching stations. Similarly, the exposure of substation to atmospheric hazards such as lightning, marine and industrial pollution etc., also play an important part in deciding the type of the bus-bar system. Future expansion of the bus-bar system at least in a foreseeable future may also be considered [2].

Busbar configuration or Bus switching scheme is the circuit adopted for substation based on following:

- System reliability
- Operational flexibility
- Ease of maintenance
- Limitation of fault level
- Simplicity of Protection system
- Ease of extension
- Availability of Land
- Cost

Bus bar provides the several alternative ways to connect the equipment like circuit breakers, isolators, earthing switches, surge arresters etc.

Important busbar arrangements include:

1. Single Bus Scheme
2. Double Bus Scheme
3. Three Bus Scheme
4. One & half breaker scheme
5. Ring or Mesh Bus Scheme

III. DESCRIPTION

1) Single Bus Scheme

This is the simplest scheme, in which each circuit is provided with one circuit breaker (Fig. (A)). this arrangement offers little security against bus bar isolator maintenance. The entire substation is lost in cases of a fault on the bus bar or only bus-bar and also in case of maintenance thereof. One of the methods for reducing the number of circuit lost in case of a bus fault is to sectionalise the bus as shown in Fig. (B)

The arrangement in Fig. (C) Shows the improvement as compared to Fig. (B) As additional by-pass isolators are provided to permit feeder circuit breaker to be taken out for maintenance without switching out the associated feeder.

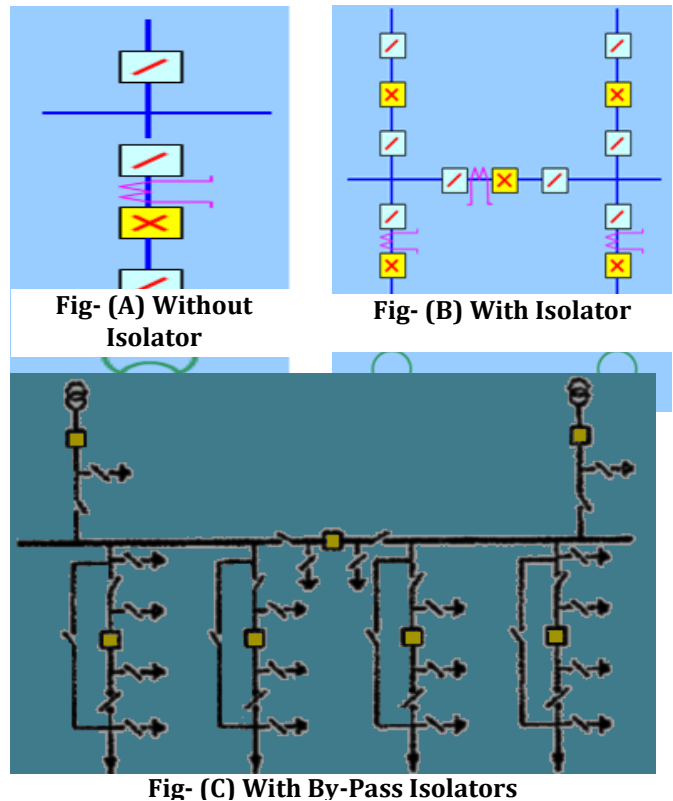

❖ Application

- Industrial stations with voltage level generally up to 145kV
- Also used for 245kV station with 2/3 bays

❖ Features

- Simple system
 - Ease of Operation & maintenance
 - Single level bus layout
- Very simple Control & Protection philosophy
- Large saving in space
- No redundancy
- It is possible to utilize the busbar potential for the line relays.
- In case of by-pass isolator the maintenance or repairs of the busbar only one half of the busbar is required to be de-energized and possibility of complete shutdown is thereby avoided.

❖ Disadvantage

- A single bus arrangement has the lowest reliability

- It is not possible to have any regular maintenance work on the energised busbar, thus for this essential job, it becomes necessary to de-energise the system.
- When a breaker on any circuit of a single busbar system fails, there will be complete shutdown of the station, for however; re-energizing first the effected circuit breaker is disconnected from the busbar with the help of isolator.
- If at any stage, a circuit is required to be added to the existing single busbar arrangement, the busbar is to be de- energised during the period the work is carried on.

2) Double Bus Scheme

In this scheme a double bus bar is provided and each circuit can be connected to one of these bus-bar isolators as shown in fig. (D). Bus coupler breaker is also provided so that circuits can be switched on from one bus to other on- load. This scheme has to limitation that only one bus is available when any breaker has to be take out for maintenance. The double bus-bar scheme with by-pass isolator across circuit breaker is very suitable for large generating stations as well as large greed substations forming part of a well interconnected system wherein a verity of grouping of circuits is required, fig. (E). Shows another alternative of this scheme in Fig. (F). In this alternative the by-pass isolators are connected to one of the main bus bar as shown. This scheme constitutes double bus-bar scheme with main reserve and transfer bus-bars.

In these schemes, use of temporary earthing device is called for during breaker maintenance. As temporary earthing drives can result in serious accidents, if not removed, it is preferable to provide the isolators on either sides of the circuit breakers across which bypass isolators are provided with integral earthing switches having mechanical interlocking features [2].

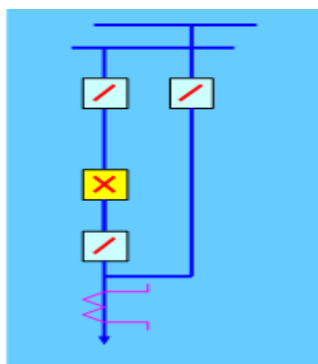

with one main & one Transfer

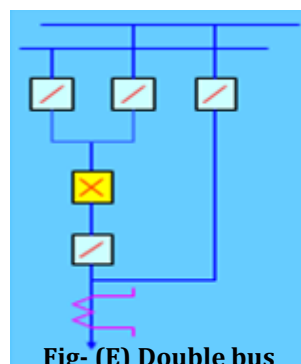

Fig- (E) Double bus with one main & one main cum Transfer

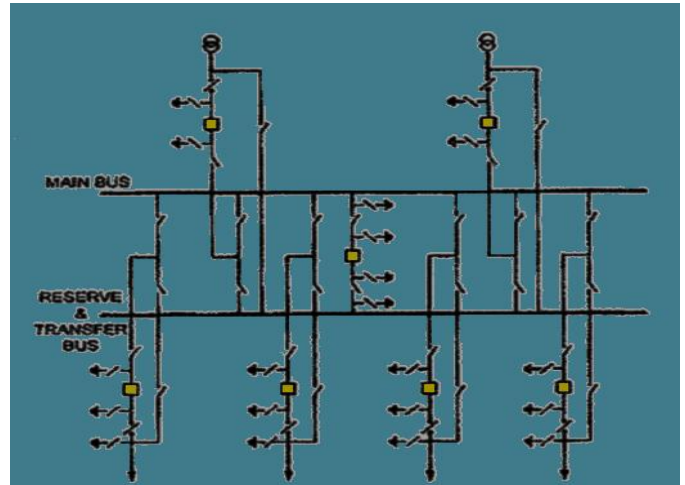

Fig- (F) Double Bus with By-Pass Isolator

❖ Application

- Normally this is used for most industrial stations and sometime small power evacuation system.

❖ Features

- Simpler system
- Reasonable in cost
- Fairly small land area
- Easily expandable
- Better availability as additional bus is provided
- Breaker can be taken out for maintenance where transfer bus feature is provide

❖ Disadvantage

- Maintenance cost are higher
- The bus is maintained or expanded by transferring all of the circuits to transfer or auxiliary bus depending upon the remote back up relay and breakers for eliminating faults of the circuits. During this condition a line fault on any of the circuits of the bus would shut down the entire station [1].

3) Three Bus Scheme

The limitation of scheme shown in Fig. (F) can be overcome by using additional transfer bus, transfer bus breaker and isolators as shown in Fig. (G) or (H). In this arrangement, the feeder, the breaker of which is to be maintained is transferred to the transfer bus without affecting the other circuits. This scheme has been widely

used for the highly interconnected power networks where switching flexibility is important and multiple supply routes are available. The scheme is also used for splitting networks, which are only connected in emergencies [2].

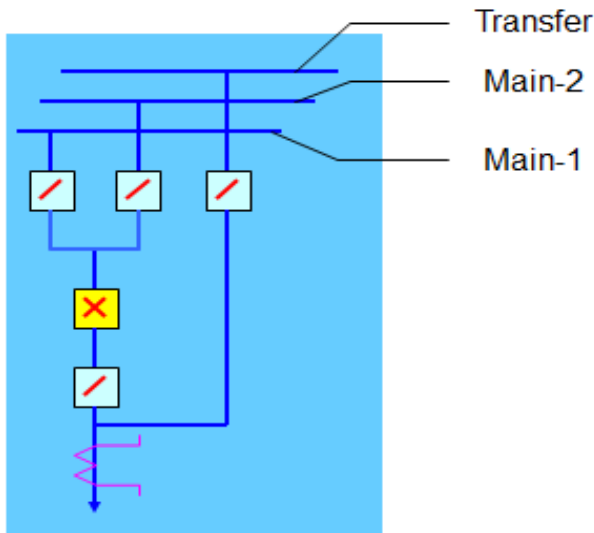

Fig- (G) Three Bus with Main I & II and separate Transfer Bus

❖ **Application**

- Power evacuation station
- Interconnecting substation for transmission lines
- Heavy Industrial stations viz. Steel, Aluminium, Petrochemicals
- Preferred by some utilities for 400 kV and 220 kV important substations.

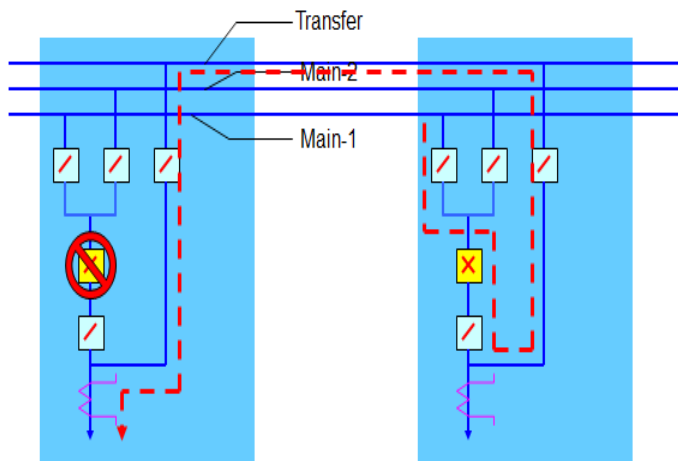

Fig- (H) Three Bus with Main I & II and separate Transfer Bus

❖ **Features**

- Independent two buses sharing the feeder
- Better load management
- Better reliability
- One transfer bay is in-built for redundancy of one bay
- Complex Control & Protection system

❖ **Disadvantage**

- High cost due to three buses

4) One & Half Breaker Scheme

In this scheme three circuit breakers are used for controlling two circuit as shown in Fig. (I & J). Each breaker is provided with two isolators and two earth switch. It is most used schemes for high voltage switchyard. Normally, both the bus-bar are in services. This scheme is suitable for those substations which handle large amounts of power on each circuit. The scheme has been widely used in USA particularly for their EHV substations operating at 330 kV and above. It is also used in India for 420 kV systems. A fault on any bus is cleared by the opening of the associated circuit breakers without affecting continuity for supply. Its operation is simple because, all load transfer is done by the breaker is possible in this scheme. However relaying is somewhat more involved as the third breaker has to be responsive to troubles on either feeder in the correct sequence. In this scheme each breaker has to be suitable for carrying operations, which may in some cases increase the cost [3].

❖ **Application**

- Mostly this configuration is adopted where high reliability is required
- Power evacuation station for big power plant
- Interconnecting transmission substations with 420/245kV level
- This scheme is popular for 400 kV and 756 kV substations in Europe. It is used for AC yards in HVDC substation in India

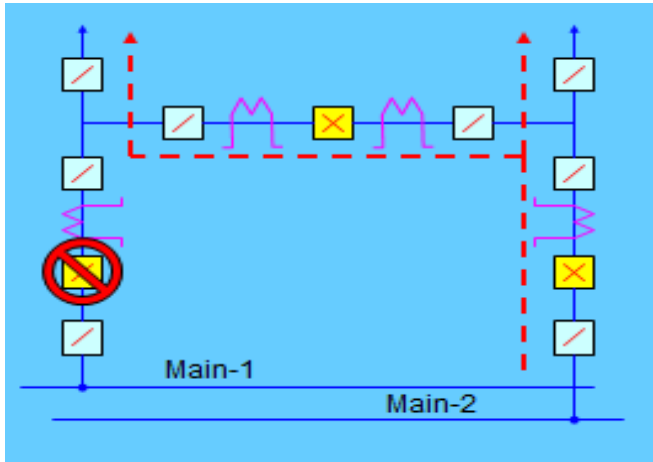

Fig- (I) One & Half Breaker Scheme

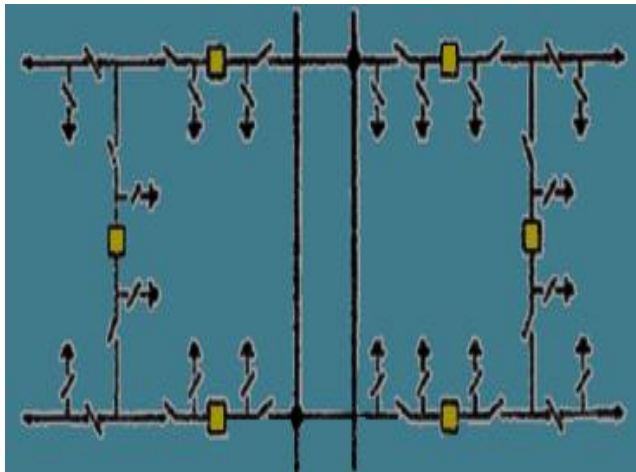

Fig- (J) One & Half Breaker Scheme

❖ Features

- Very high reliability
- Costly because of increase no. of Circuit Breaker
- Complex Control & Protection philosophy
- A fault in breaker or in a bus will not interrupt the supply.
- The bus potential can be used as supply in relay, however, at time of bus faults such potential to relay should be thrown off.
- Addition of circuits to the system is possible.

❖ Disadvantage

- The relay becomes more complicated sa compared to single bus arrangement because at the time of fault two breakers are to be opened.
- The maintenance cost is higher.

5) Ring or Mesh Bus Scheme

Each circuit is controlled by two circuit breakers and therefore, any one circuit breaker can be taken out for maintenance without affecting the security of supply as shown in Fig. (K or L). A fault on network is cleared by opening of two breakers. In both cases the ring is broken and the bus-bar is reduced to sectionalised single bus-bar scheme. In case of feeder fault, the circuit isolator can be opened, the faulty feeder disconnected and both the breakers closed which would close the ring. This scheme has some advantages as compared to other such as maintenance of a circuit breaker without loss of supply and without providing by-pass facilities, loss of only the faulty feeder in case of a feeder fault, and loss of only two circuits in case of a circuit breaker fault.

The disadvantage of this arrangement is that it makes the relaying quite complex, because of the necessary to trip two circuit breakers to isolate a faulted line. On the other hand the saving of tie circuit breaker can be taken as a big advantage in case of HV substation, as the cost of a circuit breaker is of significant value.

This scheme is very suitable where the number of circuits is comparatively small and chances of fault expansion are less such as substations associated with generating plants and also step-down substations operating at extra high voltages. This scheme has been widely used in UK for 275 kV and 400 kV substations and also in USA for their high voltage installations operating at 230 kV and above [1].

The different types of buses which can be utilized are given as:

- a) Simple ring.
- b) Rectangular ring.
- c) Circular ring.
- d) Zig-zag ring

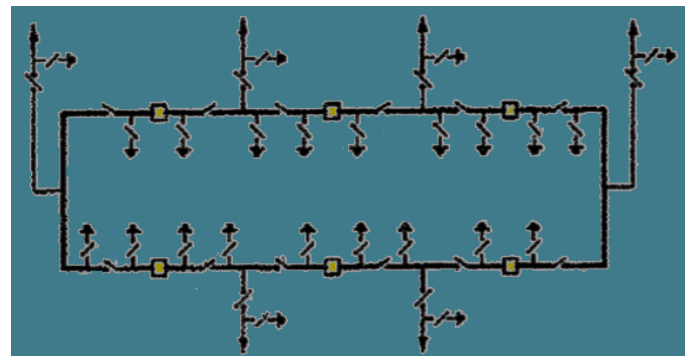

Fig- (K) Ring or Mesh Bus Scheme

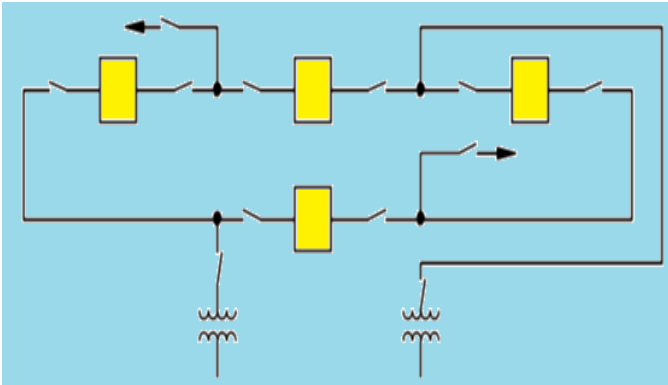

Fig- (L) Ring or Mesh Bus Scheme

❖ **Application**

- Mostly this configuration is adopted where high reliability is required
- Power evacuation station for big power plant
- Interconnecting transmission substations with 400/275 kV level

❖ **Features**

- Very reliable along with operational flexibility
- It is economical as compared to double bus bar scheme because the numbers of breakers used are nearly the same as that of single busbar system.
- It provides double feed to all the feeders at minimum cost.
- At the time of failure of the circuit breaker of bus section only the effective circuit goes out of service while the healthy circuits are not affected.

❖ **Disadvantage**

- Difficult to add new circuit in the ring.
- Necessary to supply potential to relays separately to each of the circuit.
- The opening of any section of the breaker, may cause overloading of the circuits because power can flow in one direction only.

IV. List of Bus Bar Configuration is adopted by Different Station

a) Power evacuation Substations

- Double bus scheme

- Three bus scheme
 - Two Main & one Transfer
- One & half breaker scheme

b) Transmission Substations

- Double bus scheme
- Three bus scheme
 - Two Main & one Transfer
 - One Main & Main cum Transfer
- One & half breaker scheme

c) Distribution Substations

- Single Bus with / without sectionaliser
- Double bus scheme
 - Three bus scheme
 - One Main & Main cum Transfer

CONCLUSION

In this paper an attempt is made to review most of the existing scheme of bus bar and its role in power system networks. In this we are studied on, which scheme is suitable for particular type of substations?

After studied of the entire scheme, we conclude that the selections of busbar arrangement for power system network is strongly depending on following primary consideration are:

- Bus bar arrangement should be simple.
- The maintenance should be possible without interruption of supply.
- It should not provide any danger to operating personnel while doing maintenance or repair.
- The layout should accommodate the future expansion with increase in load demand.
- It should be economical one in view of reliability and continuity of supply.

In this section, we are studied various types of bus bar arrangement scheme which are commonly used.

REFERENCES

[1] U. A. Bakshi & M. V. Bakshi, "Book of Power System-2", Technical Publications, January 2009.
 [2] G. N. Mathur, R. S. Chadha, "Manual on Substation Layout" CBIP, Publication 299, 2006.
 [3] Dr. S. L.Uppal & Prof. S. Rao, "Electrical Power Systems", Khanna Publisher, Delhi, January 2009.

- [4] "Electrical Bus System & Electrical Substation Layout", Electrical4u.
- [5] Samy M. Ghania, "Comparison Between Single and Double Bus Bar Configurations On Magnetic Field Distribution Inside High Voltage Substation", An International Journal (ESTIJ), VOL 2, ISSUE 2, April 2012.
- [6] Rakesh Swarup Mandal, "Assignment of Busbar Classification".
- [7] M. L. Sheshadri, "The Electric Sub Station" January 2016.