

Grid Connected Doubly Fed Induction Generator By Wind Power Application

Sneha Wadibhasme¹, Ankita Tak², Prof. Rahul Kirpane³

¹ BE, Electrical Engineering Department, DES'sCOET, Maharashtra, India

² BE, Electrical Engineering Department, DES'sCOET, Maharashtra, India

³ Assistant Professor, Electrical Engineering Department, DES'sCOET, Maharashtra, India

Abstract - An-Over the past few decades in power applications there is use of induction generator. In generator operation a turbine engine or prime mover drives the rotor above its synchronous speed. we know that induction generator works on faradays law of electromagnetic induction i.e., current is flowing through the stator coil then flux will generate in stator due to this flux current is induced in rotor but since the opposing rotor flux is now cutting the stator coils. Active currents is produced in stator coils and motor is operates as generator power is sends to electrical grid. Induction generators can be divided into two types according to source of reactive power first is standalone generator and another is grid connected induction generator .In case of standalone induction generator magnetizing flux produced by capacitor bank connected to a machine and in case of grid connected generator it draws magnetizing current from grid. This paper deals with grid connected a.c generator where voltage and frequency will be dictated by the electric power grid. In this type of DFIG wind turbines increasingly use in wind farms. Ability of DFIG is continuity of power supply at constant voltage and frequency. In modern control techniques such as VC and MFC are studied. Some of proposed systems are simulated in MATLAB-SIMULINK environment

Key Words: DFIG-Doubly Fed Induction Generator, VC-Vector Control, MFC-Magnitude and Frequency.

1. INTRODUCTION

Wind Power

Wind power converts wind energy into a suitable forms of energy, such as electricity generate by wind turbines in windmills for mechanical power, wind pumps for water pumping. The total amount of power available from the wind is considerably more than present human power use from all sources. Wind power as an alternative to fossil fuels. It is widely spread, clean, abundant, renewable. It does not produced greenhouse gases. Wind power is the world's rapid growing source of energy.

Why wind energy?

The large amount of electricity is generated by burning coal rather than more eco-friendly methods like hydroelectric

power. This use of coal causes environmental damage through CO₂ and other toxic gases. The energy sector is biggest source of these emissions both in the India and globally.

Benefits of Wind Power

The beneficial characteristics of wind power include:

- Endless and clean fuel: Wind power doesn't produces any emissions and is not run down with time. Generally a one megawatt (1 MW) wind turbine for one year can displace over 6.5 tons of sulphur dioxides, 3.2 tons of nitrogen oxide, 1,500 tons of carbon dioxide and 60 pounds of mercury.
- Local financial development: Wind plants can provide a income to landowners who lease their land for wind power development while increasing property tax revenues for local communities. .
- Energy price stability: By further diversifying the energy mixture wind energy reduces dependence on conventional fuels that are subject to price and supply stability.
- Reduced dependence on imported fuels: Wind energy expenditures don't need to obtain fuels from abroad, keeping funds closer to home and lessening reliance on foreign governments that supply these fuels.

2. INDUCTION GENERATOR

Induction generator or asynchronous generator is a type of AC electrical generator based on the principle of induction motors to produce power[1]. Induction generators operate by mechanically rotated their rotor in generator and gives negative slip. Most of time a regular AC asynchronous motor is used as a generator without any internal modifications.

2.1 Principle of Operation:

Induction generators and motors produce electrical power when their rotor is rotated faster than the synchronous frequency. For a typical four-pole motor or two pairs of poles on stator operating on a 60 Hz electrical grid synchronous speed is 1800rpm. And similarly four-pole motor operating on a 50 Hz grid will have synchronous speed equal to 1500

rpm. In normal motor operation stator flux rotation is faster than the rotor rotation. This is initiating stator flux to induce rotor currents, which create rotor flux with magnetic polarity opposite to stator. In generator operation a prime mover or turbine or engine drives the rotor above the synchronous speed. Stator flux still induces currents in the rotor but since the opposing rotor flux is now cutting the stator coils active current is produced in stator coils and motor is now operating as a generator and sending power back to the electrical grid.

2.2 Grid and stand-alone connections:

In case of stand-alone system and in case of grid connection it draws magnetizing current from the grid instate of in induction generator the magnetizing flux is established by a capacitor bank connected to the machine

- For a grid connected system frequency voltage of the machine will be dictated by the electric grid since it is very small compared to the whole system.
- For stand-alone systems frequency and voltage are complex function of machine parameters, capacitance used for excitation, and load value and type.

3. DOUBLY FED INDUCTION GENERATOR:

Currently DFIG wind turbines are increasingly used in large wind farms. A typical DFIG system is shown in the below figure. The AC/DC/AC converter consists of two components the rotor side converter Crotor and Grid side converter Cgrid .These converters are voltage source converters that use forced commutation power electronic devices (IGBTs) to synthesize AC voltage from DC voltage source. A capacitor connected on DC side acts as a DC voltage source. The generator slip rings are connected to the rotor side converter, which shares a DC link with the grid side converter in a so called back -to-back configuration. The wind power captured by the turbine is converted into electric power by the IG and is transferred to grid by stator and rotor windings. The control system gives the pitch angle command and the voltage commands for Crotor and Cgrid to control the power of the wind turbine, DC bus voltage and reactive power or voltage at grid terminals.

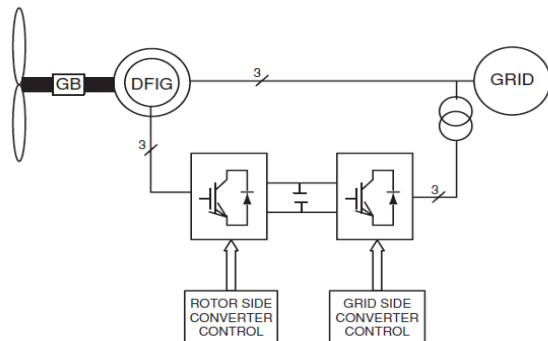

Fig -1: A DFIG and wind turbine system

OPERATION:

When the rotor speed is greater than the rotating magnetic field from stator the stator induces a large current in the rotor. The faster the rotor rotates the more power will be transferred as an electromagnetic force to the stator and in turn converted to electricity which is fed to the electric grid. The speed of asynchronous generator will change with the rotational force applied to it. Its difference from synchronous speed in percent is called generator slip. With rotor winding short circuited the generator at full load is only a few percent.

The DFIG slip control is provided by the rotor and grid side converters. At high rotor speeds the slip power is recovered and delivered to the power grid resulting in high overall system efficiency. If the rotor speed range is limited the ratings of the frequency converters will be small compared with the generator rating which helps in reducing converter losses and the system cost. Since the mechanical torque applied to the rotor is positive for power generation and the rotational speed of the magnetic flux in the air gap of the generator is positive and constant for a constant frequency grid voltage the sign of the rotor electric power output is a function of the slip sign. Crotor and Cgrid have the capability of absorbing and generating reactive power and can be used for controlling the reactive power or the grid terminal voltage. The pitch angle is controlled to limit the generator output power to its initial value for high wind speeds. The grid provides the necessary reactive power to the generator.

4. CONTROL STRATEGIES FOR A DFIG:

1. Vector control
2. Magnitude and frequency control

1.Vector Control(field oriented control theory):

The complete control strategy of the machine is divided in two parts one is scalar control and the another is vector control. The limitations of scalar control give a significance to vector control method. The scalar control strategy is modest to implement but natural coupling effect gives sluggish response. The inherent problem is being solved by the vector control. Using this control strategy an induction machine can be work like dc machine. Because of dc machine like performance vector control is also known as orthogonal decoupling. Different Vector control strategies have been proposed to control the active and reactive power of an induction generator.

The basic of the vector control theory is d-q theory. To understand vector control theory knowledge about d-q theory is essential.

D-Q Theory:

The d-q theory is also known as reference frame theory. The R. H. Park suggested a new theory to overcome the problem of time varying parameters with the ac machines. He formulated a change of variables which replace the variables related to the stator windings of a synchronous machine with variables related with fictitious winding which rotates with the rotor at synchronous speed. He transformed the stator variables to a synchronously rotating reference frame fixed in the rotor. With such transformation. He showed that all the time varying inductances that occur due to an electric circuit in relative motion and electric circuit with varying magnetic reluctances can be eliminated then H. C. Stanley showed that time varying parameters can be eliminated by transforming the rotor variables to the variables associated with fictitious stationary windings. In this the rotor variables are transformed to the stationary reference frame fixed on the stator. Then G. Kron proposed transformation of stator and rotor variables to a synchronously rotating reference frame which moves with rotating magnetic field. Latter Krause and Thomas had shown that the time varying Inductances can be eliminated by referring the stator and rotor variables to an arbitrary reference frame which may rotate at any speed.

2. Magnitude And Frequency Control:

A magnitude and frequency control (MFC) strategy has been used for the grid connected doubly fed induction generator (DFIG).The proposed MFC makes the DFIG equivalent to a synchronous generator in the power system .The active and reactive powers of the stator depend on the phase and magnitude of the new equivalent emf behind the internal transient reactance. The relationship between the rotor voltage and the emf behind the internal transient reactance is also detailed. Unlike traditional control strategies such as stator-fluxorientation vector control and FMAC the MFC method manipulates the magnitude and frequency of the rotor voltage. This simplifies the design of the control system and improves system reliability. Thus co-ordinate transformations, rotor position detection, and measurements of rotor currents and rotor speeds are not required.

Study Of WTDFIG In A 9mw Wind Farm Connected To A 25kv, 60 Hz System

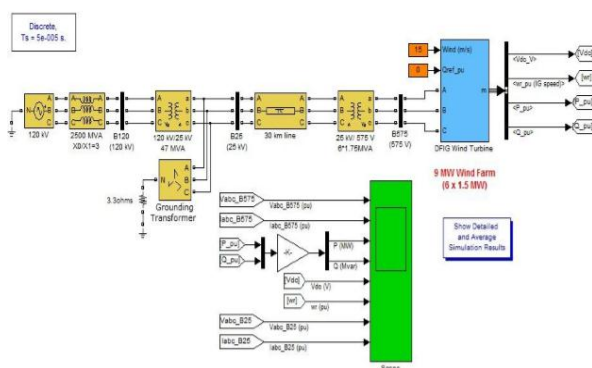

Fig -2: DFIG Average model

1

Simulation Results of DFIG Average Model

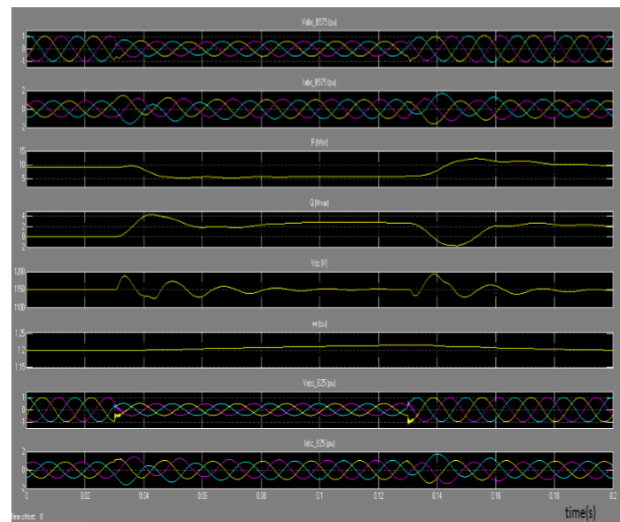

Fig -3: Simulation results of DFIG average model

5. CONCLUSION:

DFIG are generally used in Wind farms because of their ability to supply power at constant voltage and frequency. Characteristics of DFIG are studied in MATLAB environment. Control techniques of DFIG have been studied also Magnitude and Frequency control has been studied and a Simulink model for the same has been proposed. Unlike traditional methods like Stator flux orientation vector control and magnitude and frequency control method manipulates the magnitude and frequency of the rotor voltage. This simplifies the design of the control system and improves system reliability.

FUTURE WORK:

In future for improving the stability and dynamic performance of grid connected induction generator the parameters of the controllers can be improved or advanced control methods can be used.

REFERENCES

[1] Sherihan Ashraf Shaheen, Hany M. Hasanien and M. Abd-El-Latif Badr, Study of Doubly Fed Induction Generator Control, IEEE press,2010.
 [2] Zhixin Miao, Yuvarajan S Glowerj, A comparison of slip control FMA control and vector control in DFIG

converter, IECON 2008, 34th Annual Conference of IEEE,2008.

- [3] Nicholas W. Miller, Juan J. Sanchez-Gasca, William W. Price, Robert W. Delmerico, "Dynamic modelling of GE 1.5 and 3.6 mw wind turbine-generators for stability simulations," GE Power Systems Energy Consulting, IEEE WTG Modelling Panel, Session July 2003.
- [4] S. N. Bhadra, D. Kastha, S. Banerjee, Wind Electrical Systems||, Oxford University Press, New Delhi, 2009.
- [5] A.D. Hansen, and L.H. Hansen, "Wind turbine concept market penetration over 10 years (1995-2004)," Wind Energy, pp. 81-97, 2007