

# BOVINI (CATTLE) AND DAIRY FARM MANAGEMENT

Muhammad Ali

Student at Hamdard University, Karachi ,Pakistan

**Abstract:** In most of the countries large number of people lives in rural areas [1], mostly rural population involves in farming and agriculture, their mainly income depend on it. Many work had been done for cattle monitoring [2][3] but very few work had been suggested for cattle health monitoring, most recent work was presented in 2015 [4]. This paper particularly focused on the cost effective way to run the cattle farm and health monitoring as well as reducing the stress of work for labor. Results have been proved through simulation and practical on prototype.

**Key Words:** Cattle farm, Arduino, MySQL, Bovini, Solar panel, Collar Circuit, Visual studio

## 1. INTRODUCTION

Since the world has become a global village, everything becomes smart and feasible from scale to large scale. But unfortunately under developed countries like Pakistan, Sri Lanka and Bangladesh where rural conditions are not well or satisfied.

Balochistan and Khyber Pakhtunkhwa and mostly population lives under rural conditions. But farming and agriculture activities are very hard and tough for them, they do their activities in day time as most rural areas don't have electricity, life is not that very simple for them, they need to struggle for their bread. And even after the hard work and determination they are not being paid up to the mark they deserve.

And not even government are helping them, they need technology and new system for their village and for their

work but unfortunately Pakistani government only providing funds to buy land, seeds, tractor or etc. There is no plan towards modernization and introduction for new system which will make villagers life easier and increase their quality and quantity of production Pakistan have a literacy rate of 57.9% [5] as our farmer is not that educated so they mostly rely on their experience and assumption for their agriculture practice and decisions.

## 2. ISSUES AND ITS TECHNICAL BASED SOLUTION

### 2.1 Generating Electricity by Solar System

Pakistan produces around 11,500 MW per day whereas it required around 15,000 to 20,000 MW electricity per day which left with a shortfall around 4000 to 9000 MW [6].

Which make electricity expensive .Solar power is one of the best ways to produce electricity. As cattle farm does not required that much electricity so PV cell would be enough. photovoltaic plant's behavior can be predict by various ways which includes temperature, irradiance and load conditions, these factors are very important for deciding the sizing the PV plant and converter[7]

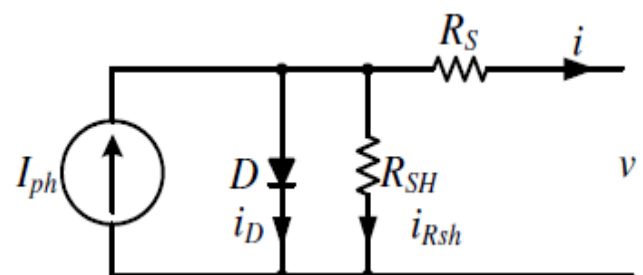

Figure 1: The equivalent circuit of the photovoltaic cell

The general current-voltage characteristic of a PV panel based on the single exponential model can be derived as:

The equation for this equivalent Circuit is formulate using Kirchoff Current law for current I

$$I = I_{ph} - I_D - I_{sh} \tag{1}$$

⇒  $I_D$  = Voltage dependent Current loss.

⇒  $I_{sh}$  = Current loss due to shunt resistance.

$$I_D = I_0 \left( e^{\frac{Vt+I_{sh}}{nsVt}} - 1 \right) \tag{2}$$

⇒ Where ns is the diode ideally factor

⇒  $I_0$  = Saturated Current

⇒  $V_t$  = thermal voltage

⇒ K = Boltzmann constant.

$$= 1.38 \times 10^{-23} \text{ J/k}$$

⇒ q = elementary charge

$$= 1.602 \times 10^{-19} \text{ C}$$

$$I_{sh} = (V + I_{Rsh}) / I_{Rsh} \tag{3}$$

$$I_{ph} = I_0 e^{\frac{V_{oc}}{nsVt}} + \frac{V_{oc}}{R_{sh}} \tag{4}$$

Substitute eq2, eq3, eq4 into eq 1

$$I = \left( I_0 e^{\frac{V_{oc}}{nsVt}} + \frac{V_{oc}}{R_{sh}} \right) - \left( I_0 \left( e^{\frac{Vt+I_{sh}}{nsVt}} - 1 \right) \right) - \left( \frac{V+I_{Rsh}}{I_{Rsh}} \right) \tag{5}$$

Where

$$V_t = \frac{AkT_{stc}}{q} \tag{6}$$

$$I_0 = \left( I_{sc} - \frac{V_{oc} - I_{sc}R_s}{R_{sh}} \right) e^{-\frac{V_{oc}}{nsVt}} \tag{7}$$

$I_{sc}$  = short circuit current

$V_{oc}$  = open circuit voltage

## 2.2. Water Management

Water is a universal need and its problem can be seen everywhere and the solution did not only lie on the availability of water but also on how water is managed [8]. The basic need for any cattle farm, is for cattle drinking purpose and by making automatically filling system for water for them will not only make water available for them but also does not require an extra labor to do this task.

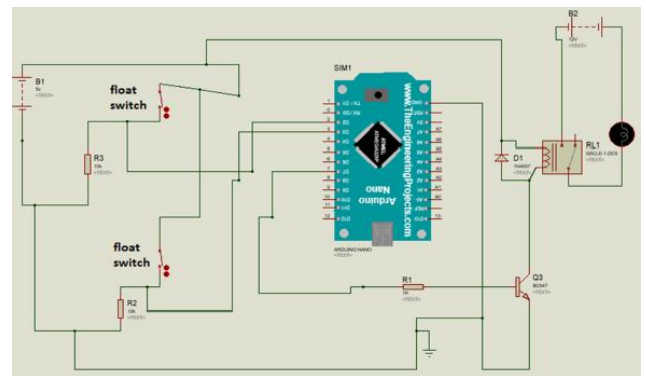

Figure 2: Automatically water filling circuit

For automatically water filling circuit two floating switch is used which will act as a reference point and make electrical solenoid valve open/ close accordingly with the help of Arduino nano controller.

## 2.3 Health Monitoring

Recent years livestock farming faced many health issues [9]. And to keep a track of cattle's health few parameters can be monitor which includes its body temperature, weight and milk measurement. These are the basic parameters which will indicate if the cattle are ill or not.

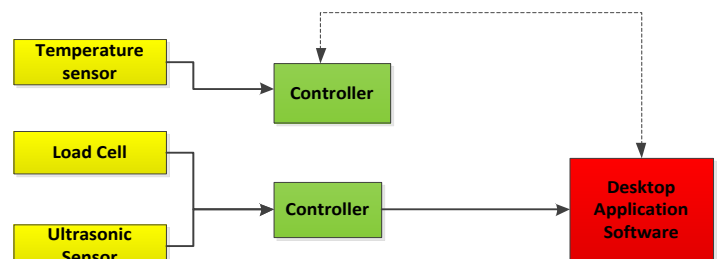

Figure 3: flowchart of health monitoring system

A desktop application is design to receive all the data from different sensors like temperature sensor, load cell and ultra-sonic sensor via Arduino controller so that user can have check and balance of their cattle.

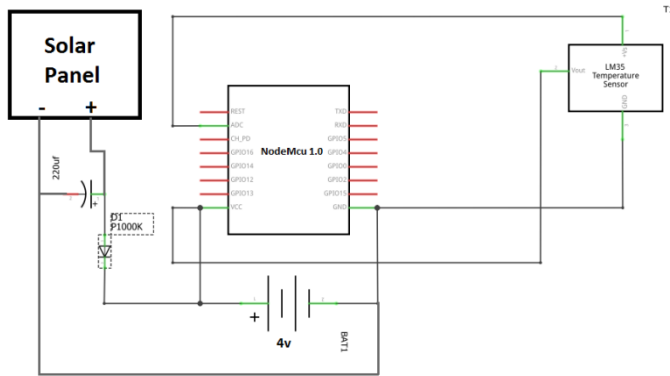

Figure 4: Temperature measuring circuit

For temperature measurement of cattle’s body a collar circuit is designed, temperature sensor (LM35) is used and placed in on the collar of the cattle for wirelessly temperature detection, this sensor is attached with Arduino NodeMcu as it have built in Wi-Fi module and small solar panel is also installed wit this circuit so that power can be taken through it. This collar circuit helps to send data wirelessly to the desktop application where data can be seen and safe. And for weight measurement load cell can be used to measure the weight of a cattle and for milking ultrasonic sensor can be placed in milking container to measure the distance of the milk and that distance can be used to measure the volume of the milk so when cattle started milking less milk so user can have indication and treat the cattle quickly.

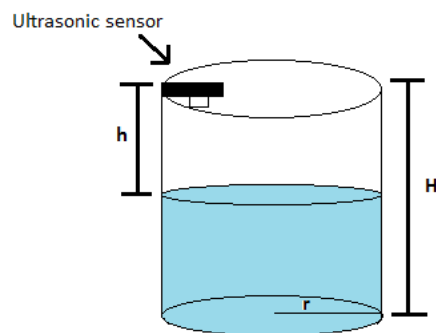

Figure 4: milking container diagram

Ultra-sonic sensor sense the empty distance and that distance can be subtracted from actual height of the container.

$$X = H - h \tag{8}$$

Then put this X into volume formula mention below

$$V = \pi r^2 X \tag{9}$$

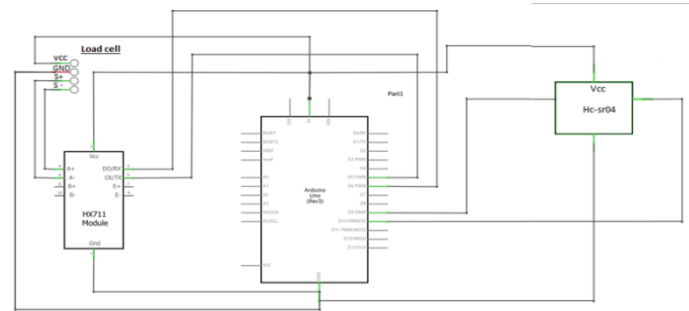

Figure 2: Automatic water filling Circuit

Ultra-sonic (Hc-sr04) is connected to Arduino Uno and load cell (5 kg) is also connected to it via HX711 weight module and it is connect to desktop application via serial communication for data transferring.

### 3. RESULTS

GUI desktop application is need where user can see the data of the cattle and can judge the unusual issue on it. GUI is designed on Visual studio where cattle’s id, temperature, milk volume, weight, date and time can be see and record in the database made on MySQL management.

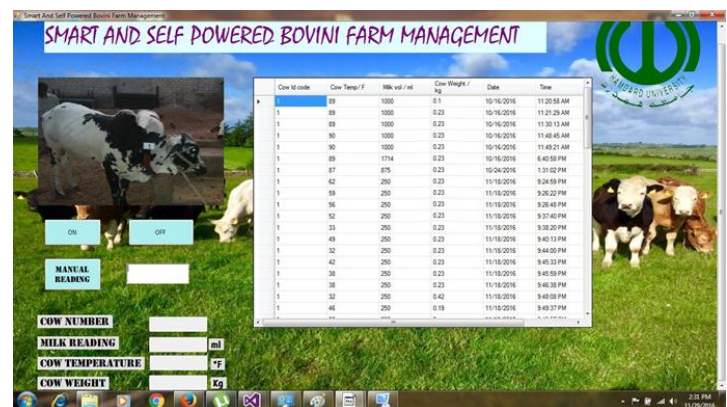

Figure 5: GUI of desktop application

Live video can be seen in user GUI, each cattle have different id attach with their collar so that data can be save with respect to their id.

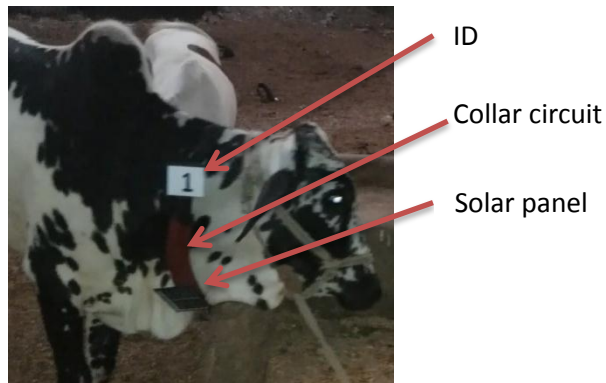

Figure 6: collar circuit with id on cattle

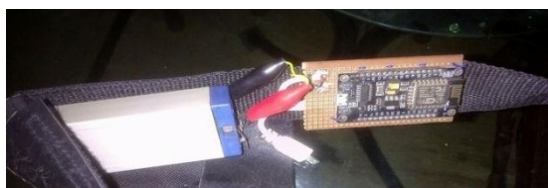

Figure 7A: collar circuit uncovered



Figure 7B: collar circuit covered

Collar circuit is designed to measure the cattle's body temperature via Wi-Fi and this circuit can be tied to cattle neck and for power 4.5V battery is connected to Arduino board and for charger a small solar panel is also attached with the battery.

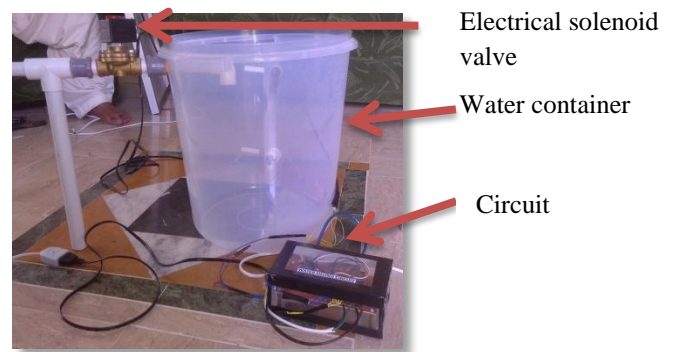

Figure 8A: Automatically water willing circuit



Figure 8B: floating switch

Two floating switch is used as a reference so that when water gets below the lower floating switch so electrical solenoid valve will open and remain open until water level reaches to upper floating switch.



Figure 10: Milk volume measurement container



Figure 11: weight measuring circuit

For milking and weight measurement, load cell and ultrasonic sensor is attached with Arduino Uno board and data will be sent to desktop application via serial communication.

#### 4. RECOMMENDATION

For future RFID tag can be introduced so that cattle's data can be record automatically and automatic milking suction system can also be install to make work faster and easier for labor.

#### 5. CONCLUSION

This is the prototype system to present the idea on how to make work easier for labor and monitor the health of cattle and also have check and balance of milk production. This system is much cheaper than modern day's system which is very expensive for poor farmer to afford it.

#### REFERENCE

1. The world bank, (2016), Rural population (% of total population). Retrieved from <http://data.worldbank.org/indicator/SP.RUR.TOTL.ZS>
2. J. I. Huirc'an, C. Muñoz, H. Young, L. Von Dossow, J. Bustos, G. Vivallo, M. Toneatti, "ZigBee-based wireless sensor network

localization for cattle monitoring in grazing fields", Computers and Electronics in Agriculture 74 (2010) 258–264.

3. K. H. Kwong, Tsung Ta Wu, H.G Goh, B. Stephen, M. Gilroy, C. Michie, and I. Andonovic, "Wireless Sensor Networks in Agriculture: Cattle Monitoring for Farming Industries", Progress In Electromagnetics Research Symposium, Beijing, China, March 23{27, 2009}
4. Kumar, A.; Hancke, G. A "ZigBee-Based Animal Health Monitoring System". IEEE Sens. J. **2015**, 15, 610–617.
5. Pakistan literacy, <http://www.indexmundi.com/pakistan/literacy.html>
6. Dunya news, <http://dunya.com/en/SpecialReport/320824-Power-and-Gas-shortage-in-Pakistan>
7. D. Sera, R. Teodorescu, and P. Rodriguez, "PV panel model based on datasheet values," in Proc. IEEE Int. Symp. Ind. Electron. (ISIE) , 2007, pp. 2392–2396
8. Asit K. Biswas, "Integrated Water Resources Management: A Reassessment A Water Forum Contribution" Water International, Volume 29, Number 2, Pages 248–256, June 2004
9. Anuj Kumar, Gerhard P. Hancke, "A Zigbee-Based Animal Health Monitoring System", IEEE SENSORS JOURNAL, VOL. 15, NO. 1, JANUARY 2015

#### BIOGRAPHIES



Muhammad Ali did his Bachelor of Engineering in Electronic from Hamdard University Karachi, Pakistan. His current research interest includes Power electronics, automation and agricultural technology.