

ARDUINO BASED BLUETOOTH OPERATED CAR WIPING TECHNIQUE USING ANDROID MOBILE PHONE

Sourish Mitra¹, Soham Biswas², Mrinmoy Aus³

¹ Assistant Professor, Dept. of Computer Science & Engineering, GNIT college, West Bengal, India

^{2,3} Student, Dept. of Computer Science & Engineering, IIIT- Kalyani, West Bengal, India

Abstract - Today's car wipers are manually operated on the principle of manual switching in every car or other vehicles. Here we propose an automatic Bluetooth based car wiper system which can automatically switches ON when detecting wireless Bluetooth signal through any android mobile phone. This proposed work can automate the wiper system having no need for manual intervention. For this purpose we use Bluetooth-HC05 slave along with microcontroller Arduino-UNO and servo-MG995 motor. Our system uses Bluetooth signal in low range from driver seat and by using Bluetooth terminal from our android mobile we can control the movement of servo motor with adjustable delay and smooth movement.

Key Words: Bluetooth-HC05, Arduino-UNO, servo-MG995, Android, wiper

1. INTRODUCTION

Arduino Uno is a microcontroller which based on the Atmel's ATmega328 chip fabricated in VLSI technique. It has fourteen digital input/output pins along with six Pulses with modulation outputs and analog inputs from Pin A0 to A5; the Arduino Uno can be powered via USB connection or with a 12 Volt external power supply. A servomotor is a rotary actuator or linear actuator that allows for precise control of angular or linear position. This kind of motor can rotate up to 180 degree starting from 0 degree with variant velocity and acceleration. It consists of a suitable motor coupled to a sensor for position feedback. HC-05 Bluetooth module is an easy to use Bluetooth Serial Port Protocol module, designed for transparent wireless serial connection setup. Serial port Bluetooth module is fully qualified Bluetooth V2.0 Enhanced Data Rate 3Mbps Modulation with complete 2.4GHz radio transceiver and baseband. In our proposed work from any android phone a Bluetooth signal is processed by microcontroller to take the desired action. The Servo works on the principle of using that Bluetooth signal for completing its circuit, so when button pressed from our android mobile phone a signal transmitted to the microcontroller. The microcontroller now processes this data and drives the servo motor to perform required action. A car wiper can attach with servomotor and controlled by android Bluetooth.

2. OUR PROPOSED WORK

In our proposed work we design a Bluetooth based android mobile operated car wiper where we can use Arduino UNO microcontroller along with HC05 slave based Bluetooth module. Hardware components and its circuit connection and operations are describe below.

2.1 Hardware Components along with Working Principle:

In our proposed work we need some hardware components to develop an efficient Arduino based Bluetooth operated car wiping technique with smooth tuning and speed controlling feature. Hardware requirements are listed below.

2.1.1 Arduino UNO R3 microcontroller board

We have used Arduino UNO R3 microcontroller development board with AtMega328P processor with +5V USB port and external +12V barrel jack port. In input/output peripheral section there are 14 pins dedicated for Digital Serial Input and output purpose (Starting from 0 upto 13, Tx and Rx are also involved in pin 0 and 1 for Serial communication). Among them pin 3, 5, 6, 9, 10 and 11 are PWM pin (Pulse width Modulation) which supports analog & digital output and Digital input. Pin A0 to pin A5 total six pins are used for analog input. Arduino can read analog data from any sensor or actuators through these pinset.

2.1.2 HC05 slave based Bluetooth Module

There are two types of module available in the market. HC05 represents both master and slave communication whereas HC06 has used as a slave only. In case of HC05 if you want to change communication mode from Master to slave or from Slave to master you must have to enter in AT command mode. For this you must connect ENABLE/KEY pin with 3.3 volt internal power of microcontroller. For this case Hc05 GND connected with GND of microcontroller and TX(Transmitter) and RX(Receiver) are connected with TX(Transmitter) and RX(Receiver) of same microcontroller. Finally VCC of HC05 module connected with 5V internal supply of microcontroller. When you switch on the module a STATE light indicator

blink after two seconds. It will indicate your module becomes on AT mode.

2.1.3 Male-Female breadboard jumper

This kind of jumper cable has length of 20cm or 8-inch. The male jumper is used for insertion into standard 0.1 inch female sockets and the female ends are used for insertion onto standard 2.54mm male headers.

2.1.4 One piece breadboard

It is a solder less temporary prototype with electronics circuit designs. Electronic components can be interconnected by inserting their leads or terminals into the holes of that board and then making connections through wires.

2.1.5 12 Volt Power Supply

It is an external power supply which provides 12 volt power to operate Arduino UNO R3.

2.1.6 Servomotor MG995

Servo is a small direct current (DC) motor which runs on electricity from a battery and spin at high RPM (rotations per minute) with very low torque. An arrangement of gears takes the high speed of the motor and slows it down while at the same time increasing the torque depending upon basic law work = force x distance. Any electric motor does not have huge torque, but it can spin really fast and angular replacement is 0 degree to 180 degree and also you can control the speed of servo motor from your microcontroller based programming.

2.1.7 Car wiper

It can operated manually by moving a lever inside the window screen of car to swipe rain drop in regular interval. In this project we can attach the wiper with servo motor and control that motor using microcontroller.

2.2 Software Requirement

- a) Arduino IDE-1.8.5. The open-source Arduino Software (IDE)
- b) Arduino Bluetooth terminal App for Android Lolipop/Kitkat OS

2.3 Proposed Working Procedure:

Our Proposed working procedure is subdivided into two sub section. First one is related with Block diagram of proposed work and 2nd section is related with circuit diagram which is internally subdivided by Circuit Connection, Circuit control with Android mobile phone and work flow diagram of proposed work.

2.3.1 Block diagram of proposed circuit

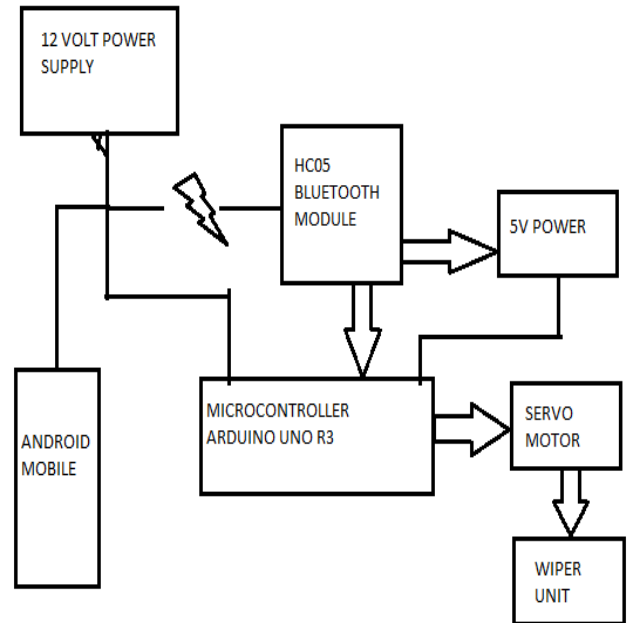

Fig-1: Block diagram of Bluetooth operated Car wiper system

According to the diagram a 12 V external Power Source can supply the 12V dc voltage to the microcontroller. Here we can use Arduino UNO R3 as a microcontroller. HC05 module can be connected with microcontroller and powered up from 5V internal supply from microcontroller. A Servo motor can be attached with microcontroller VIN pin to get 12V DC voltage. A car wiper has to attach with Servo motor.

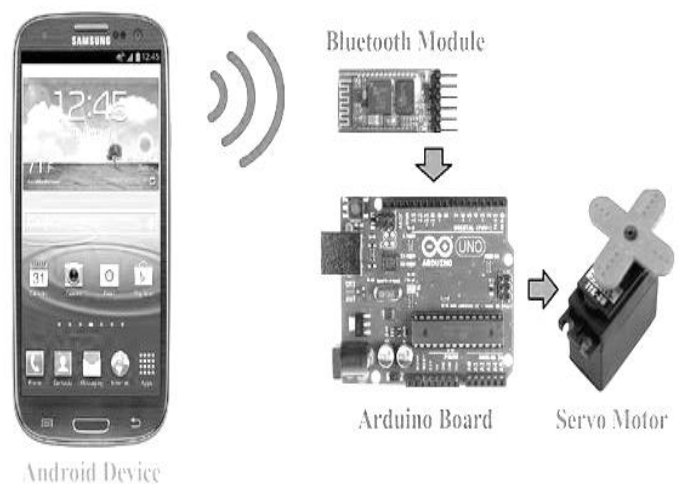

Fig-2: Architectural view with Components

2.3.2 Circuit diagram with functional explanation

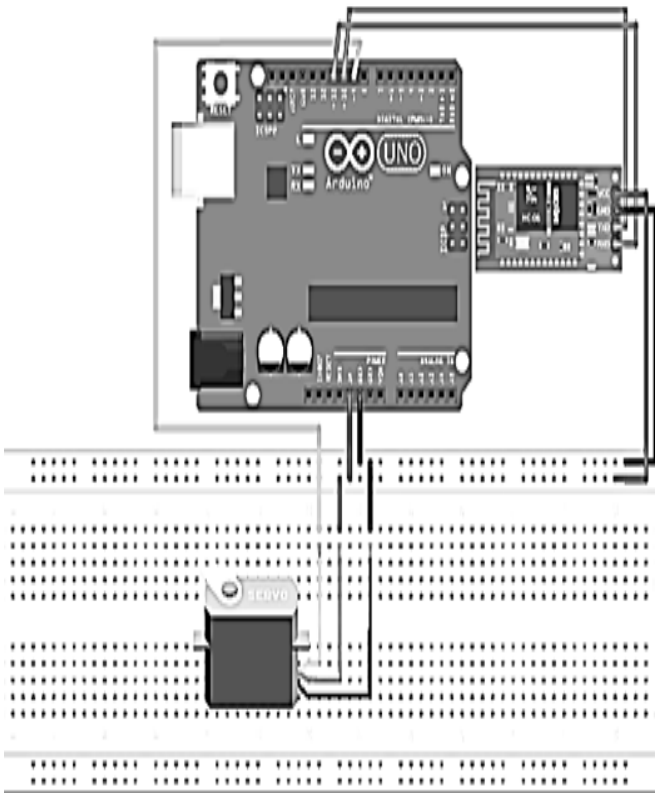

Fig-3: Circuit Diagram

2.3.2.1 Circuit Connection-1: Bluetooth HC05 to Arduino UNO R3 connection:

HC-05	Arduino
State	-
Rx	Tx
Tx	Rx
GND	GND (common ground)
+5V	Vcc (both given to common power supply)
EN	-

There are 5 pins in Bluetooth module HC05 module. All those pins are assembled into a single module. State pin indicates the status of Bluetooth module is activated or not. Rx pin indicates receiving unit of module whereas Tx indicating Transmission unit of aforesaid module. GND pin is synonymous with Ground voltage. +5V pin produce +5 Volt onboard power of that module. Finally If we want to enter inside command mode of that module then we need Enable pin (En).

2.3.2.2 Circuit Connection-2: Arduino UNO R3 Servo motor connection

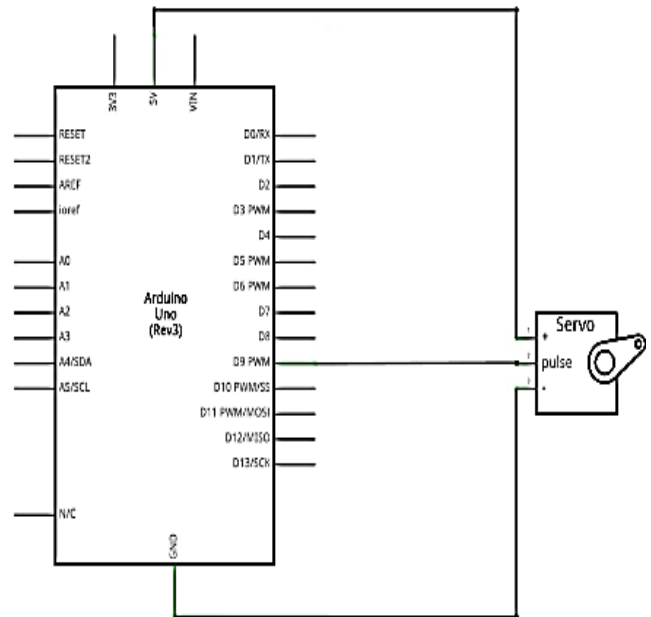

Fig-4: Circuit Diagram of Servo motor Control

According to the Circuit diagram, HC05 Bluetooth Slave module connected with Arduino UNO R3 with pin Rx to Tx and Tx to Rx (Pin 0 and 1 of Arduino Uno R3 and Tx and Rx of HC05). Enable / Key pin and State pin becomes free. When the circuit is powered on, the Arduino sketch loads the required libraries and waits to get the command characters serially from the Bluetooth module. HC05 can receive the characters from the android mobile phone can be paired. The command characters can be sent as serial data of the Bluetooth Serial Terminal applications. The HC05 module acts as a slave in this project and communicated with android phone. There are three pre-determined command characters to control the servos. If a user pressed button 2, the same servo rotates from 0 degree to 180 degree with the increment of 1degree steps with increasing speed and without delay reverse rotation can also performed from 180 degree to 0 degree with -1 decrement with that same increasing speed. If the user pressed button 3, the servo can stopped. The wiper attached with servo can be controlled by pressing button 1,2 and 3 from Android mobile Bluetooth terminal apps.

2.3.3 Circuit control with Android mobile phone

We can create our own Bluetooth pairing, connecting and controlling apps using Android lollypop. After installing that apps when we press Connect with Android device tag on that proposed apps the MAC address of Bluetooth HC05 is being displayed in front screen with value HC-05 00:21:13: 01:CD:96. After selecting that address a message displayed "Pairing and Connected". Then a Series of Button

0 to 9 displayed in front of screen. When button 1 pressed wiper along with servo start rotating from 0 to 180 clockwise and anticlockwise with low constant speed. Car wiper moved with increasing speed clockwise anticlockwise when button 2 is pressed. When we want to stop the servo rotation we need to press button 3.

2.3.3 Work Flow Diagram Of Proposed Work

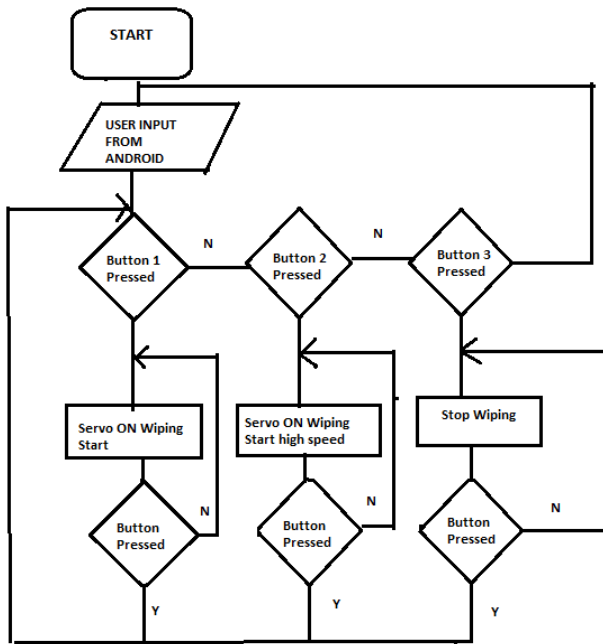

Fig-5: Flowchart of Proposed Procedure

3. CONCLUSIONS

Traditional Car wiping system is manually implemented in most of the car depending upon a switch. In some advance case it can be operated through IR remote. In our proposed Technique we can implement Android mobile phone based automatic car wiping system with speed controlling technique according to increasing rain intensity with more accurate wireless communication. Here we can use HC-05 slave Bluetooth which can be connected with android device. In this particular project work a car driver can operate this wiping technology using his android phone so that's why this work is also perfect for short range communication.

4. REFERENCES

[1] Nateq Be-Nazir Ibn Minar & Mohammed Tarique, "Bluetooth Security Threats And Solutions: A Survey", International Journal of Distributed and Parallel Systems (IJDPS) Vol.3, No.1, January 2012, pages127-148.

[2] Trishna Panse, Vivek Kapoor, "A Review on Security Mechanism of Bluetooth Communication", Trishna Panse et al, / (IJCSIT) International Journal of Computer Science

and Information Technologies, Vol. 3 (2), 2012, pages 3419-3422.

[3] Kadakia Nishant, Kothari Mohit, Shah Amit, Patel Vipul R4., "Automatic Rain Operated Wiper System in Automobile: A Review ",IJSRD - International Journal for Scientific Research & Development| Vol. 3, Issue 02, 2015 | ISSN (online): 2321-0613

[4] Usha Tiwari, Kushal Sarin, Jatin Sethi, Anshuman Gupta and Ishan Mathur, "AUTOMATIC CONTROL OF VEHICLES: An Analysis", International Journal of Advanced Research in Computer and Communication Engineering Vol. 2, Issue 4, April 2013

[5] Anuradha S. Joshi ,Sheeja S. Suresh., "REVIEW REPORT ON SOC ON VARIOUS PLATFORMS FOR VEHICLES", International Research Journal of Engineering and Technology (IRJET)

[6] Zhao Xiaoyu et.ai., "Based On Matlab Electrically Operated Wind shield Wiper Systems Design Method Research Based On Matlab Electrically Operated Windshield Wiper Systems Design Method Research" Third International Conference on Measuring Technology and Mechatronics Automation, 2011, pp. 621-624.

[7] Subankar Roy, Tashi Rapden Wang chuk, Rajesh Bhatt-Arduino Based Bluetooth Controlled Robot International Journal of Engineering Trends and Technology (IJETT), ISSN: 2231-5381, Volume-32, Issue-4, February 2016.

5. BIOGRAPHIES



Mr. Sourish Mitra, B.Tech(IT), M.Tech (Mobile Communication & NetworkTechnology), Assistant Professor, CSE Dept. Gurunanak Institute Of Technology, AICTE, UGC approved Makaut affiliated)



Soham Biswas, 1st Year, Computer science of Engineering Student of B.Tech from Indian Institute of Information Technology (IIIT), Kalyani.



Mrinmoy Aus, 1st Year, Computer science of Engineering Student of B.Tech from Indian Institute of Information Technology (IIIT), Kalyani.