

# OPTIMIZE CONTROLLING OF ACTIVE FILTERS CONTROLLED BY PI CONTROLLER

Md. Tanwirul Hasan<sup>1</sup>, Ashutosh Gupta<sup>2</sup>

<sup>1,2</sup> *Electrical and Electronics, Engineering, IASSCOM, Bhopal*

\*\*\*

**Abstract :** Due to increasing non-linear loads various undesirable effects and power quality problems induced. The use of power converters, electronic equipments and other non-linear loads are rapidly increasing in industry and also by consumers, draw non-linear currents from the AC mains as compare to traditional loads such as motors and resistive heating elements. This leads to the distortion of power system voltage and other problems. This paper presents an auto tuned active power filter for harmonic minimization and reactive power compensation of non-linear load under fast load variation condition. Improving dynamic behavior of shunt active power filter is used to tune PI controller coefficients and make it robust under random load variation.

**Key words:** Active filter, PI controller.

## 1.1 Introduction

Active power filters are more and more capturing the interest of researchers and industries owing to the decreasing quality of power supplied by the electrical distribution companies and the difficulties in fulfilling the constraints imposed by national and international standards only by using traditional compensating strategies.

The use of active systems for compensating harmonic distortion and reactive power in the supply electrical networks, both at user level or at a higher voltage level, is now more often preferred to the classical passive compensating methods. In fact active filters do not present all the typical drawbacks of passive systems such as the detuning of single tuned filters due to changes of system operative conditions and surrounding environment or the generation of resonance at particular frequencies, between the network and filter reactance, that amplifies unwanted harmonics.

In a modern electrical distribution system, there has been a sudden increase of nonlinear loads, such as power supplies, rectifier equipment, domestic appliances, adjustable speed drives (ASD), etc. As the number of these loads increased, harmonics currents generated by these loads may become very significant. These harmonics can lead to a variety of different power system problems including the distorted voltage waveforms, equipment overheating, malfunction in system protection, excessive neutral currents, light flicker, inaccurate power flow metering, etc.

To reduce harmonic distortion and power factor improvement, capacitors are employed as passive filters. But they have the drawback of bulky size, component aging, resonance and fixed compensation performance. These provide either over- or under-compensation of harmonics, whenever a load change occurs [4]. In order to overcome these problems, active power filters (APFs) have been developed. The voltage-source-inverter (VSI)-based shunt active power filter has been used in recent years and recognized as a viable solution [5].

Active filters, besides, permit the control and the compensation of distorted line currents adapting themselves to the load changes and to changing in working frequency. The most effective and the most diffuse structure in active filtering systems is certainly the shunt one composed by an inverter fed by a capacitor and a passive filter used to inject the compensating currents in the grid (Fig. 1). The aim of this kind of active filters is to generate a current waveform that is equal, but with opposite phase, to the harmonic content of the load current and to inject it in the a.c. supply system. In this way the a.c. mains will approximately deliver only the fundamental current component also with the possibility of a compensation of the find a mental reactive power.

In order to overcome these problems, active power filters (APFs) have been developed. The voltage-source-inverter (VSI)-based shunt active power filter has been used in recent years and recognized as a viable solution [5]. The control scheme, in which the required compensating currents are determined by sensing line currents only, is given in [6]-[7], which is simple and easy to implement. The scheme uses a conventional proportional plus integral (PI) controller for the generation of a reference current template.

Recently has generated a great deal of interest in various applications and has been introduced in the power electronics field [8]-[10]. The advantages of over the conventional PI controller are that they do not need an accurate mathematical model; they can work with imprecise inputs, can handle nonlinearity, and may be more robust than the conventional PI controller. Use of for minimization of harmonics and improvement of power quality is not a new issue rather various authors have introduced some innovative methodologies using these tools [11].

The most important observation from the work reported by various researchers for power quality improvement is the design of active power filter under 'fixed load' conditions or for loads with slow and small variation [12].

## 2. ABOUT THE ACTIVE POWER FILTER

When linear loads are connected to the supply the waveforms are linear. Whereas nonlinear loads are connected harmonic appears on electric voltage or current. The harmonics are integer multiples of system frequency. This leads to various power quality problems like heating of the devices, mis-triggering of the drives, pulsating output in the motors, etc., A harmonic filter are used to eliminate the harmonics. There are three basic types of harmonics filters given below.

- Passive power filters
- Active power filters

### 2.1 Passive power filters (PPF)

PPF is a type of filter, which consists of only passive components. It consists of linear elements like resistors, capacitors and inductors. They are also called as LC filters, which produce series resonance or parallel resonance that forms a major drawback of this type of filter. Another drawback of PPF is the cost which increases as the voltage rating of the inductor and capacitor increases.

### 2.2 Active power filter

APF is a type of filter that uses either current or voltage source as its major component. They compensate voltage or current harmonics by injecting the negative of the harmonic signal measured injected signals fed are of same magnitude but in phase opposition with the measured harmonic signals. Of these two voltage source based APF is more advantages.

It is controlled to draw/supply a compensated current from/to the utility, such that it eliminates reactive and harmonic currents of the non-linear load. Thus, the resulting total current drawn from the ac mains is sinusoidal. Ideally, the APF needs to generate just enough reactive and harmonic current to compensate the non-linear loads in the line [12].

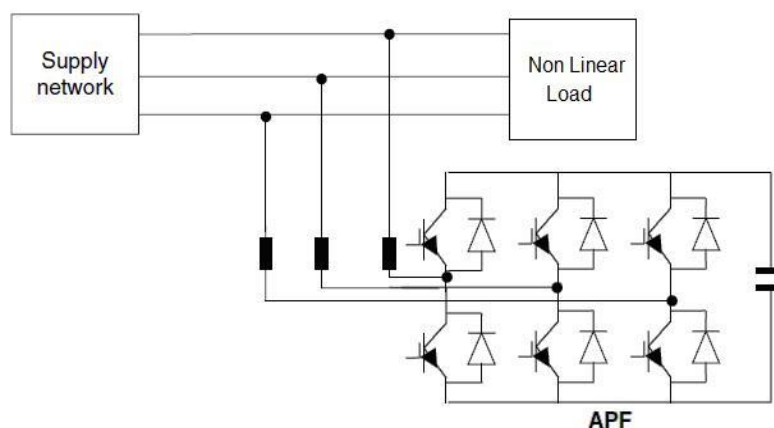

Fig. 1: Active power filter connected with transmission line

### 3. 1 Proposed PI control scheme

Figs 2 and 3 show the active power filter compensation system and the schematic diagram of the PI control scheme, respectively. In order to implement the control algorithm of a shunt active power filter, the DC capacitor voltage ( $V_{dc}$ ) is

sensed and compared with the reference value ( $V_{dcref}$ ). The Input of PI controller is the value of Error,  $e = V_{dc} - V_{dcref}$ , and its output, after a limit, is considered as the magnitude of peak reference current  $I_{ref}$ . The switching signal for the PWM converter are obtained from comparing the actual source currents ( $i_{sa}, i_{sb}, i_{sc}$ ) with the reference current templates ( $I_{sa}, I_{sb}, I_{sc}$ ) in a hysteresis current controller. The output pulses are applied to the switching devices of the PWM converter [14].

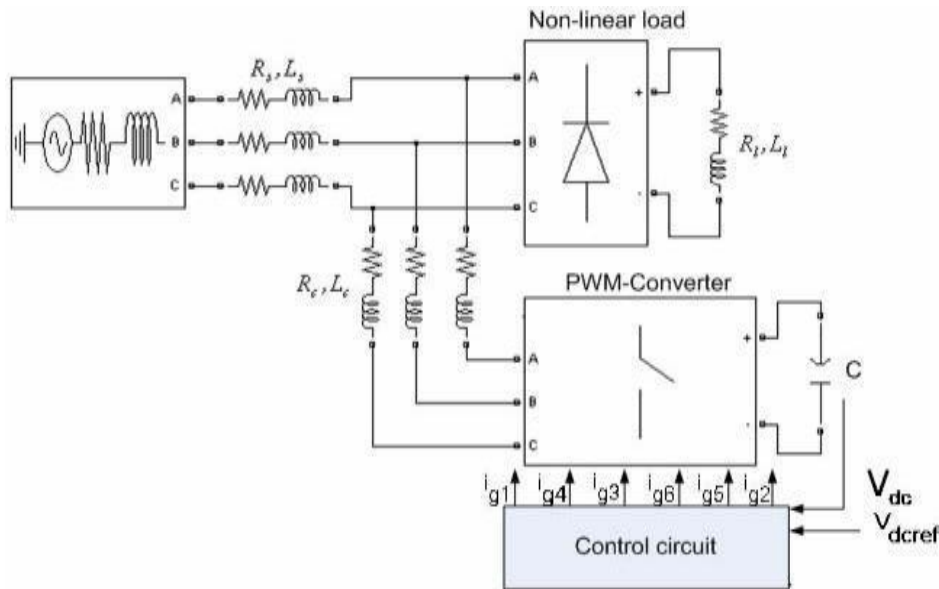

Fig. 2. Active filter controlling system.

Since coefficients of PI controller,  $K_p$  and  $K_i$ , are fixed in this model, the performance of active power filter under random load variation conditions is not as well as 'fixed load' condition. To overcome this problem and make a robust controller is designed to tune  $K_p$  and  $K_i$  on the base of load current value.

### 3. Simulink model of Active power filter using PI controller.

Fig. 3 shows the block diagram of PI controller used for the controlling of active power filter.

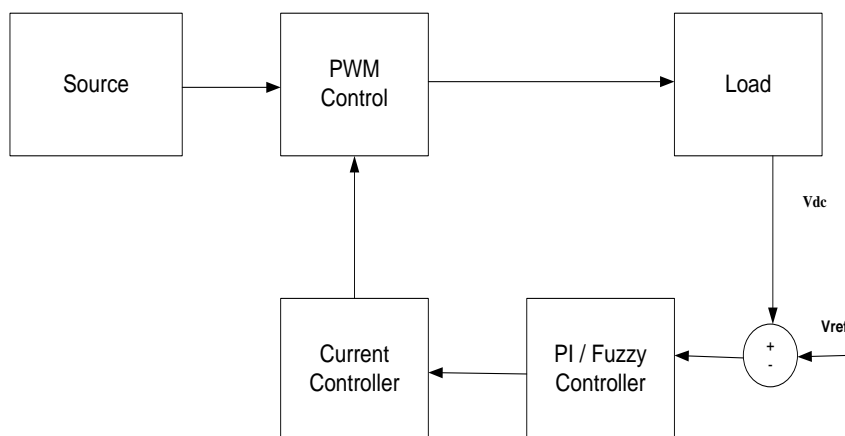

Fig. 3 Block Diagram of PI controlled improved power quality converter

The simulation is done using MATLAB for the voltage source PWM rectifier. The complete rectifier system is composed of mainly (1) three phase source, (2) voltage source PWM rectifier, (3) fuzzy controller, and (4) hysteresis controller.

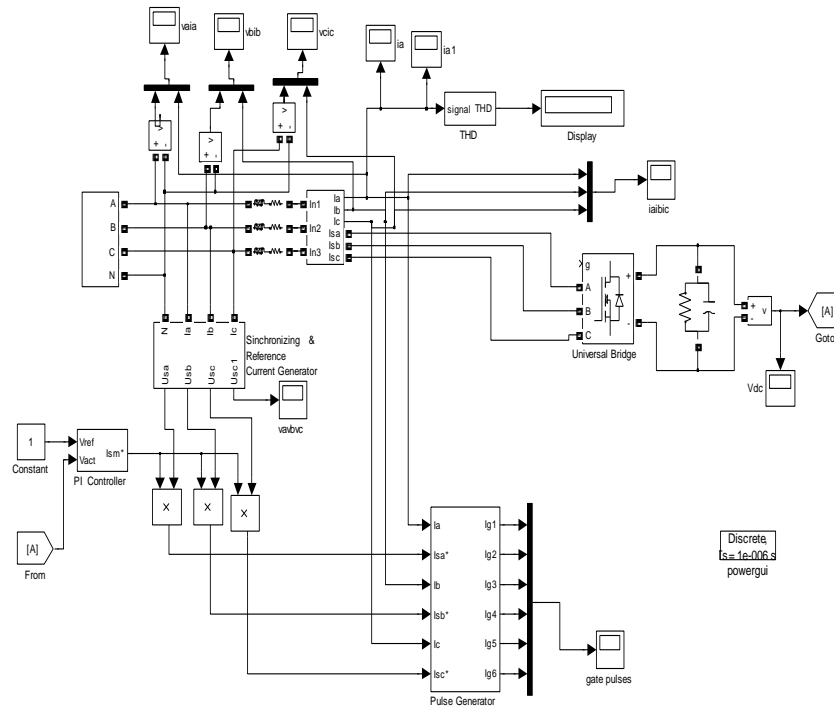

Fig. 5. Simulated power circuit without controlled improved power quality converter

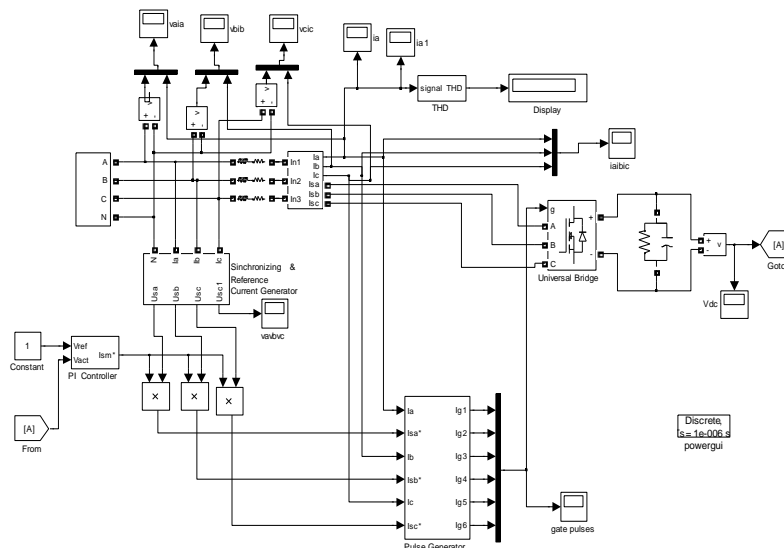

Fig. 6. Simulated power circuit for PI controlled improved power quality converter

### 5. Simulation Results

The current and voltage waveform of the conventional three phase rectifier without controller is shown in fig 7. The current waveform for one cycle and its harmonica spectrum is shown in fig 8 (a) & (b). The current is non sinusoidal and total harmonica distortion (THD) is very high (88.84%). To make the current sinusoidal and THD within permissible limit current controller is used.

### 6. Conclusion

Based on the simulation results, it can be concluded that PWM rectifier perform satisfactory for the compensation of line current. After compensation, line current become sinusoidal, balanced and in phase with the respective source voltage and reduces the THD of the source current below 5% limit. It is clear from simulation result that the transient performance of

the source current and DC side capacitor voltage is better for the PI controller in term of the setting time and % rise/fall in DC link voltage. The steady state performance of the is comparable with that of PI controller.

## References

- [1] Akagi H., "New Trends in Active Filters", 1995, EPE,17- 25.
- [2] B. S., Malesani L., Mattavelli P., 1998, IEEE Trans. on Ind. Electron., Vol. 45,722-729.
- [3] W. M. Grady, M. J. Samotyj, and A. H. Noyola, "Survey of active power line conditioning methodologies," *IEEE Trans. Power Del.*, vol. 5,no. 3, pp. 1536-1542, Jul. 1990.
- [4] V. E. Wagner, J.c. Balda, D. C. Griffith, A. McEachern, T.M.Barnes, D.P. Hartmann, D.J. Philleggi, A.E. Emmanuel, W.F. Hortion, W.E. Reid, R.J. Ferraro, W.T. Jewell, Effects of harmonics on equipments,*IEEE Trans. Power Deliv.* 8 (2) (1993) 672-680.
- [5] B. Singh, A. Chandra, and K. Al-Haddad, "Computer-aided modeling and simulation of active power filters," *Elect. Mach. Power Syst.*, vol. 27, pp. 1227-1241, 1999.
- [6] K. Chatterjee, B. G. Fernandes, and G. K. dubey, "An instantaneous reactive volt-ampere compensator and harmonic suppressor system," *IEEETrans. Power Electron.* vol. 14, no. 2,pp. 381-392, Mar. 1999.
- [7] S. Jain, P. Agarwal, and H. O. Gupta, "Design simulation and experimental investigations on a shunt active power filter for harmonics and reactive power compensation," *Elect. Power Compon. Syst.*, vol.32, no. 7, pp. 671-692, Jul. 2003.
- [8] B. K. Bose, *Expert Systems, Fuzzy Logic and Neural Network Application in Power Electronics and Motion Control.* Piscataway, NJ: IEEE Press, 1999.
- [9] V. S. C. Raviraj and P. C. Sen, "Comparative study of proportional integral, sliding mode, and fuzzy logic controllers for power converters,"*IEEE Trans. Ind. Appl.*, vol. 33, no. 2, pp. 518-524, Mar./Apr. 1997.
- [10] Dell'Aquila, A. Lecci, and V. G. Monopoli, "Fuzzy controlled active filter driven by an innovative current reference for cost reduction," in *proc. IEEE Int. symp. Ind. Electron.*, vol. 3, May 26-29, 2002, pp. 948-952.
- [11] J. A. Momoh, X.W. Ma, K. Tomsovic, Overview and Literature survey of fuzzy set theory in power systems, *IEEE Trans. Power Syst.* 10 (August (3)) (1995) 1676-1690.
- [12] G.K. Singh, A.K. Singh, R. Mitra., "a simple fuzzy logic based robust active power filter for harmonics minimization under random load variation" *Electr. Power Syst. Res.* (2006).
- [13] Recommended Practices and Requirements for Harmonic Control in Electronic Power Systems, IEEE Standard 519-1992, New York, 1993.
- [14] C. N. Bhende, S. Mishra, and S. K. Jain, "TS-Fuzzy-Controlled Active Power Filter for Load Compensation", *IEEE Transactions on Power Delivery*, Vol. 21,No. 3, July. 2006.
- [15] A. Elmitwally, S. Abdelkader, M. Elkateb "Performance evaluation of fuzzy controlled three and four wireshunt active power conditioners" *IEEE Power Engineering Society Winter Meeting*, 2000. Volume 3, Issue, 23-27 Jan 2000 Page(s):1650 – 1655 vol.3.