

On the Performance of Carrier Interferometry OFDM by Wavelet Transform

Cebraïl CIFLIKLI¹, Bilgin YAZLIK²

¹Professor, Department of Electronics and Automation, Erciyes University Kayseri Vocational College, Melikgazi, Kayseri, Turkey

²Specialist, Erciyes University Technology Development Zone, Melikgazi, Kayseri, Turkey

Abstract - Nowadays, orthogonal frequency division multiplexing (OFDM) is attracting a great deal of attention. However, the many advantages responsible for the widespread application of OFDM systems are limited by multipath fading. To enhance the performance of OFDM, many models utilize channel coding. Recent studies have focused on carrier interferometry coding for OFDM. In this paper, we present a novel design of carrier interferometry (CI) spreading codes by using a wavelet transform instead of a fast Fourier transform (FFT) which is widely used for realizing carrier interferometry in OFDM systems. The performance of the proposed technique is simulated over Rayleigh fading and Rician fading channels. In the simulations, the performances of OFDM, FFT-based CI/OFDM, and wavelet transform-based CI/OFDM over multipath channels are compared. The simulation results show that the wavelet-based CI codes are more robust at SNR larger than approximately 10 dB over the Rician fading and 7 dB over the Rayleigh fading channels.

Key Words: Carrier interferometry, Multipath fading, OFDM, Wavelet transform, FFT.

1. INTRODUCTION

In the recent years, OFDM has great attention, OFDM gives opportunities to system designers especially when they need high data rates. Today, there is a huge demand for mobile devices which connect to internet and this situation leads high data usage on wireless communications systems. To be able to get high data rates on wireless communication systems, multicarrier schemes can be employed and OFDM is one of the best multicarrier scheme [1].

In OFDM, high-speed data stream is converted into low-speed parallel data streams with the help of serial-parallel convertors. Then, these low-speed data streams are sent to channel by using of orthogonal carriers. We know that OFDM can reduce inter-symbol interference, because it has flat fade carriers [2]. This situation leads to unique carrier signals with different amplitudes.

PAPR reduction and BER performance increase are possible by the use of carrier interferometry (CI) codes as spreading codes in OFDM systems. In the literature, many techniques have been proposed for using CI in OFDM systems. CI/OFDM improves the performances of OFDM-based WLANs as presented in [3]. It is possible to implement CI codes in CDMA and TDMA wireless systems [4, 5] and 64-QAM OFDM systems [6]. Moreover, in [7, 8, 9] pseudo-orthogonal CI coding has been used in OFDM systems. CI codes are spreading codes and are of different types, such as coded CI [10] and turbo coded CI [11]. In [12], CI OFDM is realized by using FFT and the effect of the proposed technique in terms of average bit error rate (BER) is analyzed. Narrowband interference rejection in OFDM via CI is carried out by Nassar in [13].

In the literature, many articles show that a wavelet transform has many advantages over a fast Fourier transform (FFT) [14, 15]. While a FFT gives only frequency components of the signal, a wavelet transform can supply both time and frequency information simultaneously.

In this paper, we present a novel design of CI spreading codes by using a wavelet transform instead of a FFT, because of the advantages of wavelet transform. The performance of the proposed technique is simulated over Rayleigh fading and Rician fading channels for an OFDM system. In the simulations, the performances of OFDM, FFT based CI/OFDM and wavelet transform based CI/OFDM over multipath channels are compared. The simulation results show that the wavelet transform-based CI codes are more robust to narrowband interference than are FFT-based CI codes.

2. CI /OFDM SYSTEM DESCRIPTION

In Figure 1, a block diagram of the conceptual CI/OFDM transmitter is given. As shown in this figure, system modulates every symbols onto all carriers and system uses carrier interferometry codes to spread the symbols to same carrier, carrier interferometry can be considered as phase offset. We can define CI spreading code for kth symbol as: $\beta^k = (e^{j0}, e^{j\Delta\theta k}, \dots, e^{ji\Delta\theta k}, \dots, e^{j(N-1)\Delta\theta k})$,

where $\Delta\theta_k = (2\pi/N)k$ which helps to secure orthogonality among transmitted symbols [4].

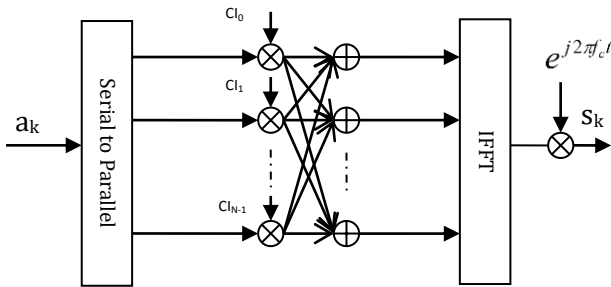

Fig - 1: Conceptual block diagram of the CI/OFDM transmitter

The symbol which is transmitted in a CI/OFDM for kth symbol is:

$$s_k(t) = A \cdot \text{Re} \left\{ \sum_{i=0}^{N-1} \alpha_k^n e^{j(2\pi f_c t + 2\pi f_i t + \frac{2\pi}{N} \cdot k \cdot i)} \right\} \quad (1)$$

where α_k^n is the nth symbol in the kth symbol stream, $2\pi/N \cdot k \cdot i$ is the phase offset value and it is used to get the spreading code of the kth symbol and it helps to secure orthogonality among the N symbols and A defines energy.

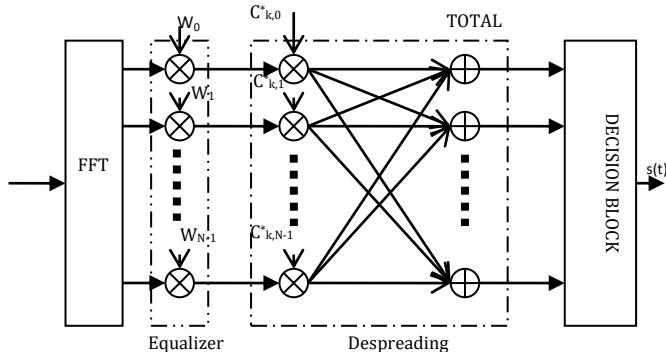

Fig - 2: Conceptual block diagram of the CI/OFDM receiver

The received signal for CI/OFDM system is mathematically described as:

$$s(t) = A \cdot \sum_{k=0}^{N-1} \sum_{i=0}^{N-1} \alpha_k^n \cos \left(2\pi f_c t + 2\pi f_i t + i \cdot \frac{2\pi}{N} \cdot k \right) \quad (2)$$

3. DESCRIPTION OF THE PROPOSED CI/OFDM SYSTEM

In this paper, we obtained the CI codes by using a wavelet transform. In Figure 3, the block diagram of the proposed

system is given. As shown in this figure, the wavelet transform is applied to a baseband modulated signal for realizing CI. The background of the proposed system is based on the block. In the transmitter, data are modulated with a QAM modulator, and after QAM modulation the signal is spread by the wavelet as in a CI/FFT system. CI code length is equal to number of carrier. Then the spread signal is modulated by using an inverse fast Fourier transform (IFFT). After IFFT step we used wavelet to realize CI spread. The resulting symbols after the IFFT block are extended by using a cyclic prefix and transmitted over the fading channel. At the receiver end, operations inverse to those realized at the transmitter end are carried out.

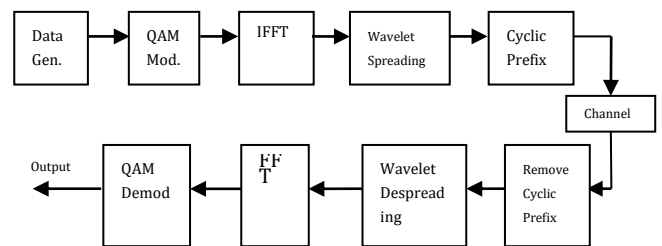

Fig - 3: Block diagram of the proposed CI/OFDM system

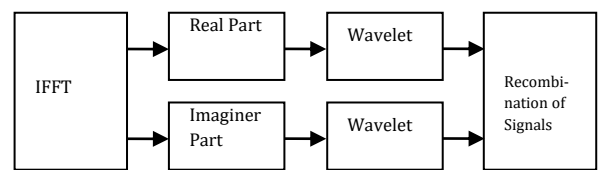

Fig - 4: Block diagram of the proposed CI/OFDM system's wavelet spreading phase

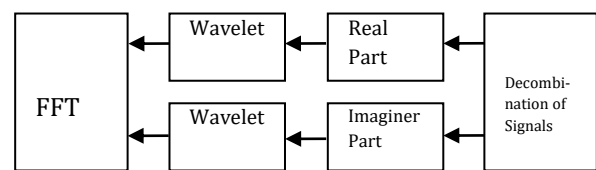

Fig - 5: Block diagram of the proposed CI/OFDM system's wavelet despreading phase

4. WAVELET TRANSFORM

Wavelet transform contributes to analyze of the signals not only by their frequency domain but also by the time domain. FFT gives us only frequency information, but wavelet transform supplies both frequency and time information of the signal. To be able to analyze the signal both in time and frequency domains, it is necessary to

divide the signal into small parts. At this work, we use Haar filter for wavelet transform. The Haar filter is:

$$h_k(t) = \frac{1}{\sqrt{N}} \begin{cases} 2^{a/2} & (l-1)/2^a \leq t < (l-0.5)/2^a \\ -2^{a/2} & (l-0.5)/2^a \leq t < l/2^a \\ 0 & \text{otherwise} \end{cases} \quad (3)$$

While a , determines the amplitude of the function; l , determines location of the function. Haar transform filter is orthogonal as well as the CI codes.

In this paper we have realized carrier interferometry OFDM with the wavelet transform instead of FFT. The results show that the system has better performance than the original CI-FFT OFDM system, but this system demands more energy and computational power.

5.SIMULATIONS AND RESULTS

In this section, we test the performance of the wavelet-based CI/OFDM system and compare with the performance of the OFDM system and FFT-based CI/OFDM system in the presence of narrowband interference. Simulations are performed over AWGN, Rayleigh and Rician fading channels in the MATLAB environment. The results show that proposed system performs same under AWGN but better under Rayleigh and Rician fading channels.

Table - 1: Simulation Parameters

Number of Subcarrier	256
Baseband Modulation	QPSK
Wavelet Function	Haar
Level of Wavelet	8
FFT Size	256
Cyclic Prefix	64
CI Code Length	256

Totally 10 coefficients are used in algorithm such as level of wavelet, fft size, number of sub carrier etc.

Because of its symmetric, orthogonal, biorthogonal structure, Haar is selected. The subject of the paper is in mainframe to send an orthogonal signal to the receiver so that it is important to use orthogonal system to improve the performance.

In Figure 6, the performance of the proposed system is given for the AWGN fading channel. It can be seen in the figure that the OFDM system based on CI using both a wavelet transform and FFT is more robust than the OFDM system without CI.

In Figure 7, the performance of the proposed system is given for the Rayleigh fading channel. It can be seen in the figure that the OFDM system based on CI using both a wavelet transform and FFT is more robust than the OFDM system without CI. Moreover, the proposed system performs better over the Rayleigh fading channel. In particular, the wavelet-based technique is more robust at SNR larger than approximately 7 dB.

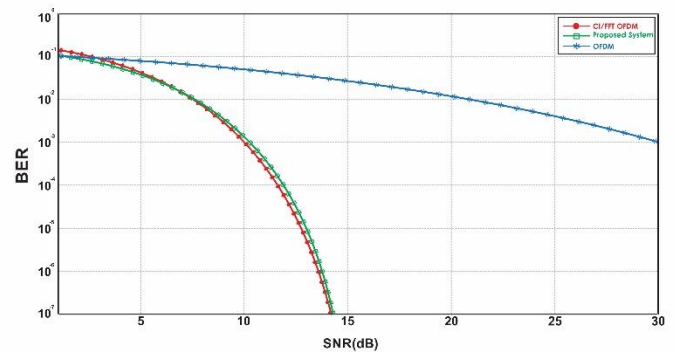

Fig - 6: Performance of the proposed system over a AWGN channel

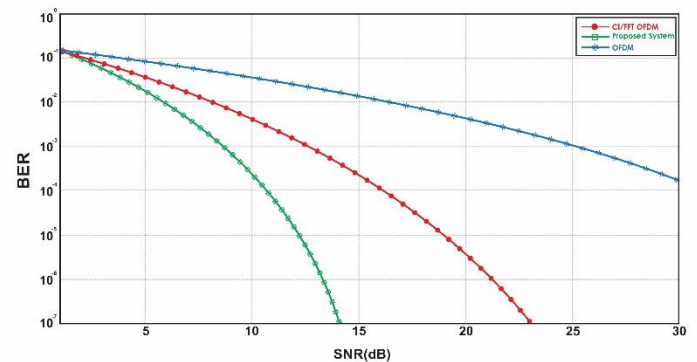

Fig - 7: Performance of the proposed system over a Rayleigh fading channel

In Figure 8, the performance of the proposed system is given for the Rician fading channel. It can be seen in the figure that the OFDM system based on CI using both a wavelet transform and FFT is more robust than the OFDM system without CI. Moreover, the proposed system performs better over the Rician fading channel. The wavelet-based technique is more robust at SNR larger than approximately 10 dB.

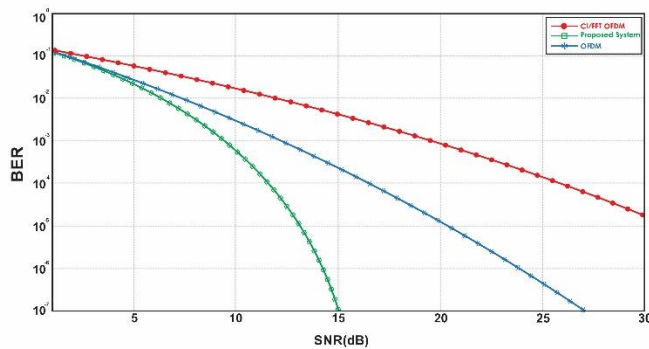

Fig – 8: Performance of the proposed system over a Rician fading channel

6. CONCLUSIONS

A novel wavelet-based CI/OFDM system is proposed in this paper as an alternative to FFT-based CI/OFDM systems in the presence of narrowband interference. The performance of the proposed system is simulated in the MATLAB environment over AWGN, Rayleigh and Rician fading channels and compared to OFDM and FFT-based CI/OFDM systems. The simulation results show that the wavelet-based system is absolutely robust to narrowband interference. Furthermore, the proposed system performs better than the OFDM system without CI and FFT-based CI/OFDM proposed in the literature. The wavelet-based technique is more robust at SNR larger than approximately 10 dB over the Rician fading channel and 7 dB over the Rayleigh fading channel. Wavelet transform of course makes the system a bit more complex, for example simulation takes 130,19 seconds for proposed system in Rician channel but 88,84 seconds takes for traditional CI system, further works will be focused on that point. We know that CI codes improve PAPR performance of OFDM systems. PAPR performance of the proposed system will be investigated for future work.

REFERENCES

[1] Richard. V., N., Prasad, R., OFDM for Wireless Multimedia Communications, Artech House, Boston, 1999.

[2] S. Santoso, E. J. Powers, W. M. Grady, P. Hoffman, "Power quality assessment via wavelet transform analysis", IEEE Transactions on Power Delivery, vol. 11, April 1996, pp. 924-930, <http://dx.doi.org/10.1109/61.489353>.

[3] Wiegandt, D., A., Wu, Z., Nassar, C., R., "High performance carrier interferometry OFDM WLANs: RF testing", IEEE International Conference on

Communications, 11-15 May. 2003, pp. 203 - 207, <http://dx.doi.org/10.1109/ICC.2003.1204170>.

[4] Balasubramaniam Natarajan, Carrier interferometry for next generation CDMA and TDMA wireless systems: A multi carrier framework, Ph.D. Thesis, Colorado State University, 2002.

[5] Balasubramaniam N., Carl R. N., Steve S., Marco M., Zhiqiang W., "High-performance MC-CDMA via carrier interferometry codes", IEEE Transactions on Vehicular Technology, vol. 50, 6, Nov. 2001, pp. 1344-1353, <http://dx.doi.org/10.1109/25.966567>.

[6] Zhiqiang W., Zhijin W., David A. W., Carl R. N., "High-performance 64-QAM OFDM via carrier interferometry spreading codes", IEEE Vehicular Technology Conference, 6-9 Oct. 2003, pp. 557-561, <http://dx.doi.org/10.1109/VETEFC.2003.1285079>.

[7] Wiegandt D.A., Nassar C. R., "High-throughput, High-performance OFDM via Pseudo-Orthogonal carrier interferometry coding, personal, indoor and mobile radio communications", 12th IEEE International Symposium, 30 Sept.-3 Oct. 2001, pp. 98-102, <http://dx.doi.org/10.1109/PIMRC.2001.965328>.

[8] David A. W., Zhiqiang W., Carl R. N., "High-throughput, High-performance OFDM via pseudo-orthogonal carrier interferometry spreading codes", IEEE Transactions on Communications, vol. 51, July 2003, pp. 1123-1134, <http://dx.doi.org/10.1109/TCOMM.2003.814196>.

[9] Jun L., Lenan W., "Comments on high-throughput, high-performance OFDM via pseudo-orthogonal carrier interferometry spreading codes", IEEE Transactions on Communications, vol. 55, no. 1, Jan. 2007, pp. 232-234, <http://dx.doi.org/10.1109/TCOMM.2007.896136>.

[10] Fumiaki M., Hans-Peter K., "Performance of space diversity reception for coded carrier interferometry OFDM", IEEE Vehicular Technology Conference, 17-19 May. 2004, pp. 520-524, <http://dx.doi.org/10.1109/VETECS.2004.1388007>.

[11] Yeonho C., Wanwoo S., "On the performance of turbo coded carrier interferometry OFDM transmission system", The 6th International Conference Advanced Communication Technology, 2004, pp. 269-272, <http://dx.doi.org/10.1109/ICACT.2004.1292871>.

[12] Khoirul A., Heiichi Y., "A new design of carrier interferometry OFDM with FFT as spreading codes", IEEE Radio and Wireless Symposium, 17-19 Jan. 2006, pp. 543-546, <http://dx.doi.org/10.1109/RWS.2006.1615214>.

[13] Zhiqiang W., Carl R. N., "Narrowband interference rejection in OFDM via Carrier interferometry spreading codes", IEEE Transactions on Wireless Communications, vol. 4, July 2005, pp. 1491-1505, <http://dx.doi.org/10.1109/TWC.2005.850288>.

[14] Akin, M., "Comparison of wavelet transform and FFT methods in the analysis of EEG signals", Journal of Medical Systems, vol. 26, June 2002, pp. 241-247, <https://doi.org/10.1023/A:1015075101937>.

[15] A. Grossmann, J. Morlet, "Decomposition of hardy functions into square integrable wavelets of constant shape", SIAM J. Math. Anal., vol. 15, no. 4, July 1984, pp. 723-736, <http://dx.doi.org/10.1137/0515056>.

[16] B.G. Negash, H.Nikookar, "Wavelet based OFDM for wireless channels", IEEE Vehicular Technology Conference, 2001, pp. 688-691, <http://dx.doi.org/10.1109/VETECS.2001.944931>.

[17] M. Sifuzzaman, M.R. Islam, M.Z. Ali, "Application of wavelet transform and its advantages compared to fourier transform", Journal of Physical Sciences, 2009, pp.121-13, <http://dx.doi.org/10.1.1.457.854>.

BIOGRAPHIES



Cebraail Ciftlikli was born in K. Maras, Turkey, in 1961. He received the Ph.D. degree in electronics engineering from Erciyes University in 1990. In 2004, he joined Erciyes University Kayseri Vocational College as Professor where he is now Principal. Dr. Ciftlikli's current research interests include spread-spectrum communications, wireless ATM/LAN, signal processing, DS-CDMA system engineering, RF power amplifier linearization for wireless communication systems.



Bilgin Yazlik was born in Van, Turkey, in 1983. He is PhD student in Erciyes University. Since 2005 he has been working as a Specialist at Erciyes University, Kayseri and he is general manager at Erciyes Science Park. His current research interests are in the areas of carrier interferometry, computer grids, multi-carrier communications.