

# Microcontroller Based Automatic Street Light Monitoring and Control System

Md. Mayn Uddin

Department of Electrical and Electronic Engineering, Jatiya Kabi Kazi Nazrul Islam University  
Trishal, Mymensingh-2220, Bangladesh

\*\*\*

**Abstract** - In the present world, street lights are required. In order to busy lifestyle of humans, switching operations on streetlights are not carried out on time and a huge amount of electricity is being wasted. In the present system, it is observed that street lights are not turned OFF even when there is a small amount of light after sun rise and are not turned ON even before sunset. Even in timer based street light control systems, the ON and OFF time differ during sunny and rainy days. To overcome these problems, an automatic street light controller is to be designed. It is designed to detect vehicle movement on highways to switch ON only a block of street lights ahead of it (vehicle) and to switch OFF the trailing lights to save energy. During night all the lights on the highway remain ON for the vehicles. But, lots of energy is wasted when there is no vehicle movement. Once the lights are switched on current sensors placed at every street light circuits are responsible to report problem status to the centralized system with help of GSM module attached with the circuit. The status is available in the centralized system, the workman now can easily locate the particular light to take care which minimizes the time to search it and to repair.

**Key Words:** Street Light, Current Sensor, GSM, Light Detecting Resistor (LDR), AVR microcontroller.

## 1. INTRODUCTION

A well-designed, street lighting system should permit users to travel at night with good visibility, in safety and comfort, while reducing many malfunctions occurs during night. Conversely, poorly designed lighting systems can lead to poor visibility which may not be helpful for anyone who are passing by that street. Quite often, street lighting is poorly designed and maintained (e.g., there are large numbers of burned-out lamps) and uses imperfect lighting technology, thus consuming large amounts of energy and financial resources.

Providing street lighting is one of the most important and expensive responsibilities of a city. Street lighting is a particularly critical concern for public authorities in developing countries because of its strategic importance for economic and social stability. Our proposed plan for street light monitoring and control system can provide street lighting maintenance. This maintenance can also enable municipalities to expand street lighting to additional areas,

increasing access of providing street light for all the streets and also other underserved areas.

The application is designed in such a way that light sensors are placed in all the street lights circuit and which are responsible to switch on and off automatically. Once the lights are switched on, current sensors placed at every light pole are responsible to report problem status to the centralized system with the help of GSM module attached with the circuit. With the status available in the centralized system, the workman now can easily locate the particular light to be taken care which minimizes the time to search it and to repair. The system also collects useful information from each street light at the end of each day. The information is stored in the database and based on this information charts are derived. The charts are displayed in the street light section which contains information like power consumption, total number of burning hours, total number of interruptions, tallies the actual power consumption with the power supplied, details of fault detection i.e., actual location of street light. The system is also provided with optimal sleep scheduling protocol to increase the lifetime of the street lights.

This kind of proposed effective street lighting is an important way of increasing road safety at night; it improves the quality of life for residents by deterring crime and by improving the ambience of areas, which is commercially beneficial to businesses and the prosperity of the city as a whole. Our aim is to achieve individual faults repaired within few working hours instead of taking some days/even months.

## 2. EXISTING SYSTEM

Industry of street lighting systems are growing rapidly and going to complex with rapid growth of industry and cities. Automation, Power consumption and Cost Effectiveness are the important considerations in the present field of electronics and electrical related technologies. To control and maintain complex street lighting system more economically, various street light control systems are developed. These systems are developed to control and to reduce energy consumption of a town's public lighting system using different technologies. The existing work is usage of the High intensity discharge lamp (HID). HID presently used for urban street light are based on principle of gas discharge, thus the

intensity is not been controllable by any voltage reduction method as the discharge path is broken. In existing system, there is also a problem that there are many street lights that are fully or slightly damaged. These may be repaired after a long period of time. So, people do not fill safe and they face many problems with it.

Disadvantages of Existing System:

- HID lamps consume more power.
- The life time of the HID lamps is very less.
- It cannot be used in all outdoor applications.
- It may take some days/even months to repair the fault of lights.

3. LITERATURE SERVEY

Automatic Street Light, it is all about to control the power consumptions at the streets and eliminating manpower. This includes controlling a circuit of street lights with specific sensors, LDR and Microcontrollers during day and night. This needs three basic components i.e. LDR, Sensors and requirement of street lights so that the LDR keeps the street light off until the light level is low or the frequency of light is low the resistance of the LDR is high. This prevents current from flowing to the base of the transistors that is effective. Thus, the street lights do not glow [1].

Automatic Street Light Control System Using Microcontroller, the work aims at designing and executing the advanced development in embedded systems for energy saving of street lights. Nowadays, human has become too busy and is unable to find time even to switch the lights wherever not necessary. This paper gives the best solution for electrical power wastage. Besides this, the manual operation of the lighting system is completely eliminated. In this paper, the two sensors are used which are Light Dependent Resistor (LDR) sensor to indicate a day/night time and the photoelectric sensors to detect the movement on the street. ATmega16 microcontroller is used as the brain to control the street light system where the programming language used for developing the software to the microcontroller is C-language [2].

Intelligent Street Lighting System Using GSM, Conventional street lighting systems in areas with a low frequency of passers are by online most of the night without purpose. The consequence is that a large amount of power is wasted meaninglessly. With the broad availability of flexible-lighting technology like light-emitting diode (LED) lamps and everywhere available wireless internet connection, fast reacting, reliably operating and power-conserving street lighting systems become reality. The aim of this work is to explain the Intelligent Street Lighting (ISL) system, a first approach to accomplish the demand for flexible public lighting systems [3].

GSM based smart street light monitoring and to increase the efficiency and accuracy of an industry by automatically timed controlled switching of street lights they are basically two modules which include the client side and the server side. The client side consists of GSM modem which is further connected to the microcontroller which is further connected to the relay circuit; the server side consists of GSM modem connected to the Monitoring and Control Application.

4. PROPOSED MODEL

A. Block diagram

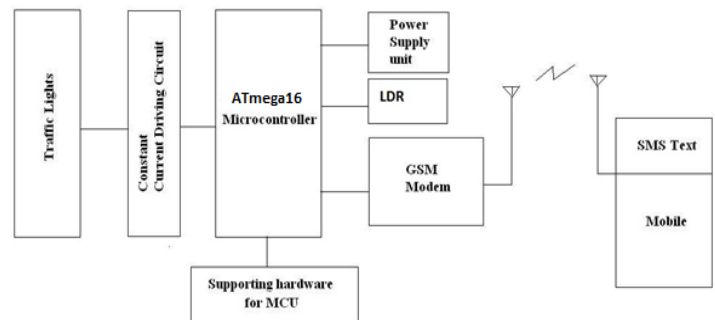

Figure 1. Block diagram of Microcontroller Based Automatic Street Light Monitoring and Control System

B. Hardware implementation

1) ATmega16 microcontroller: ATmega16 is an 8-bit high performance microcontroller of Atmel's Mega AVR family with low power consumption. It is known that ATmega16 is based on enhanced RISC (Reduced Instruction Set Computing) architecture with 131 powerful instructions. Most of the instructions execute in one machine cycle. ATmega16 can work on a maximum frequency of 16MHz.

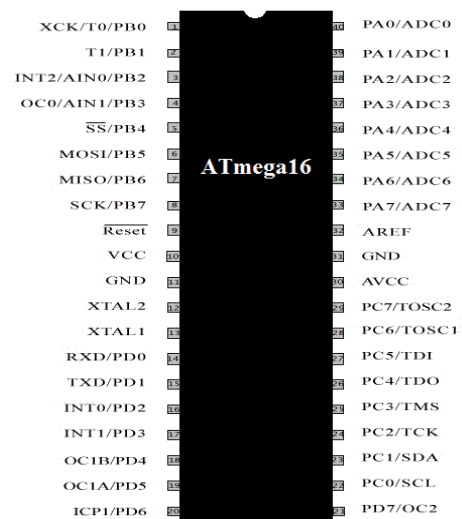

Figure 2. ATmega16 microcontroller

ATmega16 has 16 KB programmable flash memory and EEPROM of 512 Bytes. Its static RAM is 1 KB. The endurance cycle of flash memory and EEPROM is 10,000 and 100,000 respectively. ATmega16 is a 40 pin microcontroller. There are 32 I/O (input/output) lines which are divided into four 8-bit ports designated as PORTA, PORTB, PORTC and PORTD. Atmega16 has various in-built peripherals like USART, ADC, Analog Comparator, SPI, JTAG etc. Each I/O pin has an alternative task related to in-built peripherals [4].

2) *Light Detecting Resistor (LDR)*: An LDR (Light Detecting Resistor) is used as a light sensor to measure the ambient light levels and input them to the MCU (Microcontroller Unit). It is known that an LDR is a light-controlled variable resistor. It exhibits photoconductivity. The resistance value of the LDR increases with decreasing incident light intensity levels and vice-versa. It is considered that this photo-detector is dealing for lighting automation [5].

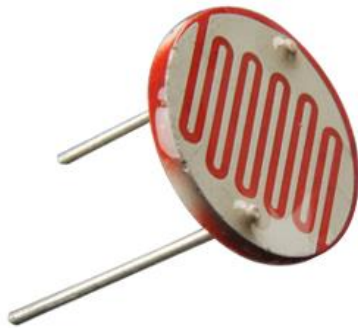

Figure 3. LDR

As LDR is light dependent device whose resistance decreases when light falls on them and increases in the dark due to high resistance. If the device is allowed to absorb light, its resistance will be decreased drastically. If a constant voltage is applied to it and intensity of light is increased, the current starts increasing.

3) *GSM Modem*: A GSM modem is a specialized type of modem which accepts a SIM card and operates over a subscription to a mobile operator, just like a mobile phone. From the mobile operator perspective, a GSM modem looks just like a mobile phone. When a GSM modem is connected to a computer, then this allows the computer to use the GSM modem to communicate over the mobile network. While these GSM modems are most frequently used to provide mobile internet connectivity, many of them can also be used for sending and receiving SMS and MMS messages. A GSM modem can be a dedicated modem device with a serial, USB or Bluetooth connection, or it can be a mobile phone that provides GSM modem capabilities in effective way [6].



Figure 4. GSM Modem

For the purpose of this document, the term GSM modem is used as a generic term to refer to any modem that supports one or more of the protocols in the GSM evolutionary family, including the 2.5G technologies GPRS and EDGE, as well as the 3G technologies WCDMA, UMTS, HSDPA and HSUPA.

### 5. METHODOLOGY

The application is designed in such a way that light sensors are placed in all the street lights circuit which are responsible to switch on and off automatically. Once the lights are switched on, current sensors placed at every light poles are responsible to report problem status to the centralized system with the help of GSM module attached with the circuit. With the status available in the centralized system, the workman now can easily locate the particular light to be taken care which minimizes the time to search it and to repair. The system also collects useful information from each street light at the end of each day. The information is stored in the database such as power consumption, total number of burning hours and number of interruptions, tally the actual power consumption with the power supplied, details of fault detection i.e., actual location of street light.

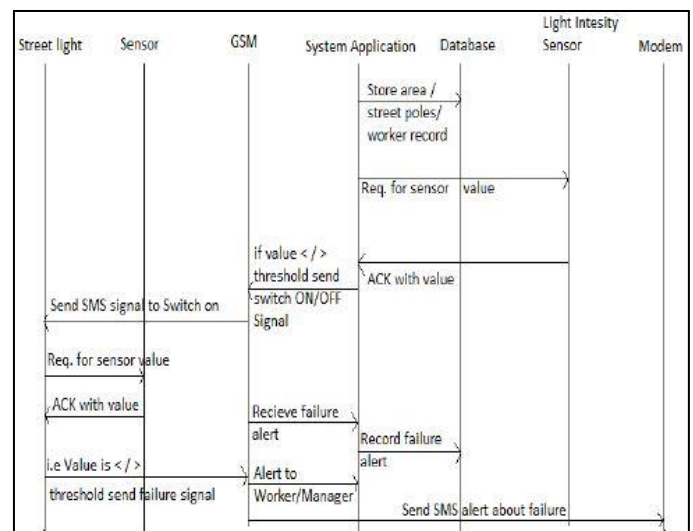

Figure 5. Sequence Diagram

## 6. CIRCUIT DIAGRAM

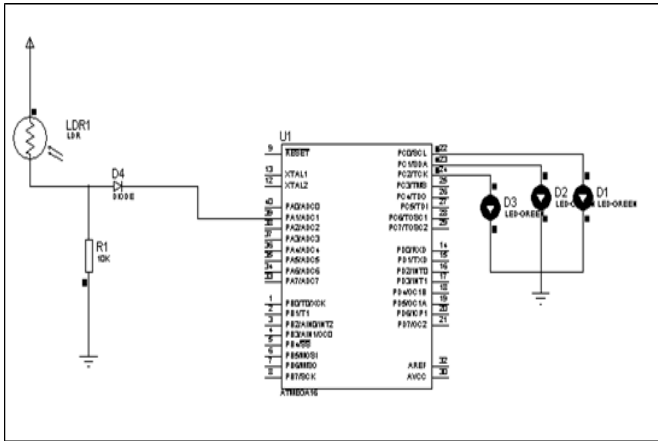
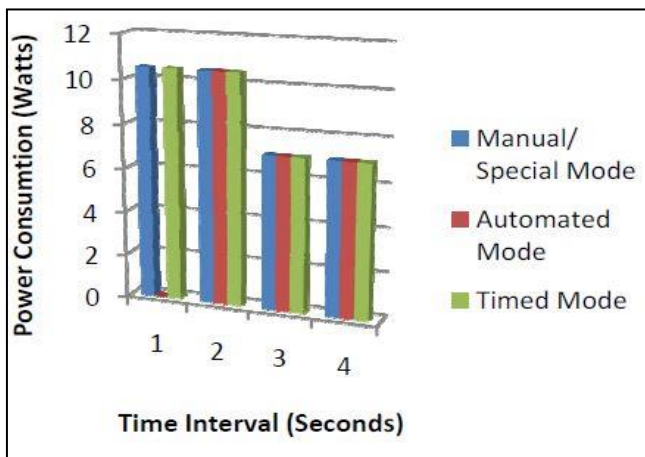

Figure 6. Circuit diagram of Sensor Based Automatic Street Light System

## 7. RESULT AND DISCUSSION



In above bar graph manual/special mode, automated mode is shown. The manual mode is operated in special cases (Govt. Functions) and the power is high. Whereas in automated mode, LDR is used to switch ON/OFF of lights automatically is the best feasible solution. In Timed Mode, there is in switch ON/OFF light without intervention of human using time specified by the Admin. The 3rd and 4th time interval in the shedding is taking place, hence the power consumption is optimized.

## 8. APPLICATIONS

- Corporate field.
- Street lights (KPTCL).
- Home power control system.
- Institutions/Organization [7].

## 9. SCOPE

- Automatic switching off alternate time for power consumption.
- Switch on and off automatically.
- Street light false detection.
- Alert notification and automatic off for particular street light if there is any abnormal/subnormal consumption of power to avoid short circuit or any such related problems, also message to the respective workman.
- The useful information is collected from the street light at the end of each day. This information is stored in a database and based on this information charts are derived.
- Chart contains information like Power consumption, total number of burning hours and total number of interruptions.
- Wireless Communication.
- Can be deployed on any street light circuit.
- Reduces power consumption.
- Reduces human resource.
- Increases the life time of the street light [8].

## 10. PROBLEMS & TROUBLESHOOTING

The harder part in this paper is that it is difficult to work with the ADC values of the sensors. It is difficult to work smoothly depending upon only the ADC values of the sensors. Sometimes, the soldering connections create problems. All the circuits need to be water proofed otherwise these may be damaged. So, it is recommended that all of complexities should be handled carefully.

## 11. CONCLUSION

Here, using this methodology two-way communication can be possible. Technical solution for implementation of wireless intelligent smart street lighting system is made easier. It provides a low cost infrastructure for managing street lighting system. Single point controlling of street lights is made possible. Energy consumption can be controlled making it eco-friendly in usage.

## 12. FUTURE WORK

Street Light may be glowed on detecting vehicle movement. Then, it provides low power consumption. Solar cell can also be used instead of electricity for less power consumption. If any unwanted occurrence such as accident occur, then it will be informed by the nearest police station and hospital. The CO<sub>2</sub>



gas sensor may be attached to the system to provide a means of comparing gas sources being able to set an alarm limit when the source becomes excessive. The sound sensor may be added to the system to detect the sound strength and the vehicle may be alerted by the GSM module to control it.

### 13. REFERENCES

- [1]S. Srivastava, "Automatic Street Lights"
- [2]V.V.S. Madhuri, P.Mallikarjuna Sarma, N.SandhyaRani, "Automatic Street Lighting using PLC"
- [3]Prof. K.Y. Rajput, Gargeyee Khatav, Monica Pujari, Priyanka Yadav, "Intelligent Street Lighting System using Embedded System"
- [4]<http://www.engineersgarage.com/electronic-components/atmega16-microcontroller>
- [5]<http://www.electroschematics.com/6355/ldr-light-dependent-resistor-photoresistor>
- [6] <https://www.nowsms.com/faq/what-is-a-gsm-modem>
- [7]<http://www.edgefxkits.com/blog/light-dependent-resistor-ldr-with-applications>.
- [8] Bulbul Bhaskar, R. Swarnalatha, "Smart Home Automation System using AVR Microcontroller", International Journal of Advanced Technology in Engineering and Science, Volume No.03, Issue No. 02, February 2015, ISSN (online): 2348 – 7550