

EXTRACTION OF CARBON BLACK FROM ORGANIC COMPOUND

Rahul G.Karmankar

Assistant Professor, Mechanical Engineering department, Nagpur University, Maharashtra, India

ABSTRACT: This papers show the carbon black and its manufacturing process. Carbon black is produced by the incomplete combustion of hydrocarbon or thermal cracking. The blacks falls into three groups by method of manufacture: (1) channel (2) furnace, and (3) thermal. The average particle size of blacks range from about 15 to 275 milli-microns. The finest black are channel blacks and coarsest are the thermal blacks, but there is some overlapping of the furnace blacks at both ends. Carbon blacks are not pure carbon but contain varying amounts of hydrogen and oxygen. The principal effect of this non-carbon material seems to be on the surface characteristics, specially the pH. The channel blacks are acid, while furnace blacks and thermal blacks are neutral or alkaline. The acid blacks are slower curing and generally require more accelerator for good cure. As a group, the carbon blacks have probably received the greatest amount of study both as to method of manufacture Carbonization (or carbonization) is the term for the conversion of an organic substance into carbon or a carbon-containing residue through pyrolysis or destructive distillation.

The soot of a natural gas flame, used in paints is fine carbon. Also called channel black.

Keywords— Carbon black , coconut shell, crusher.

INTRODUCTION

Carbon black is the main constituents produced by the incomplete combustion of coconut shell. Carbon are the main element to absorb the unwanted electromagnetic wave. These are finely powder made by different no. of coarse size. Carbon black is potentially useful as an alternative material to absorb and attenuates electro magnetic interference (EMI). The surface morphology of the raw materials in term of porosity is investigated by using TM3000 Scanning Electron Microscope (SEM). Carbon materials are a very good absorbent of electromagnetic energy as it is easily heated by it. The surface morphology of the raw materials in term of porosity is investigated by using TM3000 Scanning Electron Microscope (SEM).. All carbon blacks have chemisorbed oxygen complexes i.e., carboxylic, quinonic, lactonic, phenolic groups and others) on their surfaces to varying degrees depending on the conditions of manufacture. These surface oxygen groups are collectively

referred to as volatile content. It is also known to be a non-conductive material due to its volatile content. The coatings and inks industries prefer grades of carbon black that are acid oxidized. Acid is sprayed in high temperature dryers during the manufacturing process to change the inherent surface chemistry of the black. The amount of chemically-bonded oxygen on the surface area of the black is increased to enhance performance characteristics. Carbon black (subtypes are acetylene black, channel black, furnace black, lamp black and thermal black) is a material produced by the incomplete combustion of heavy petroleum products such as FCC tar, coal tar, cracking tar, and a small amount from vegetable oil. Carbon black is a form of Para crystalline carbon that has a high surface-area-to-volume ratio, albeit lower than that of activated carbon. It is dissimilar to soot in its much higher surface-area-to-volume ratio and significantly lower (negligible and non-bioavailable) PAH (polycyclic aromatic hydrocarbon) content. However, carbon black is widely used as a model compound for diesel soot for diesel oxidation experiments. Carbon black is mainly used as a reinforcing filler in tires and other rubber products. In plastics, paints, and inks carbon black is used as a color pigment. Total production was around 8,100,000 metric tons (8,900,000 short tons) in 2006.^[4] The most common use (70%) of carbon black is as a pigment and reinforcing phase in automobile tires. Carbon black also helps conduct heat away from the tread and belt area of the tire, reducing thermal damage and increasing tire life. Carbon black particles are also employed in some radar absorbent materials used in the reduction of the radar cross-section of aircraft and in photocopier and laser printer toner, and other inks and paints. The high tinting strength and stability of carbon black has also provided use in coloring of resins and films.^[5] About 20% of world production goes into belts, hoses, and other non-tire rubber goods. The balance is mainly used as a pigment in inks, coatings and plastics. For example, it is added to polypropylene because it absorbs ultraviolet radiation which otherwise causes the material to degrade. Carbon black from vegetable origin is used as a food coloring, in Europe known as additive **E153**. It is approved for use as additive **153** (Carbon blacks or Vegetable carbon)^[6] in Australia and New Zealand^[6] but has been banned in the US.^[7] Carbon black has been used in various applications for electronics. As a good conductor of electricity, carbon black is used as filler mixed in plastics, elastomeric, films, adhesives, and paints.^[5] Application of carbon black as an antistatic agent has provided uses as an

additive for fuel caps and pipes for automobiles. Additionally, the color pigment Carbon Black has been widely used in food and beverage packaging around the world for many years. It is used in multi-layer UHT milk bottles in the US, parts of Europe and Asia, and South Africa, and in items like microwavable meal trays and meat trays in New Zealand. Within Australasia the safe use of the color pigment Carbon Black in packaging must comply with the requirements of either the EU or US packaging regulations and if any colorant is used it must meet European partial agreement AP(89)1.^[8]The Canadian Government's assessment (an extensive review of Carbon Black) in 2011 concluded that Carbon Black should continue to be used in products – including food packaging for consumers – in Canada. This was because “in most consumer products carbon black is bound in a matrix and unavailable for exposure, for example as a pigment in plastics and rubbers” and “it is proposed that Carbon Black is not entering the environment in a quantity or concentrations or under conditions that constitute or may constitute a danger in Canada to human life or health.”^[9]There are strict guidelines available and in place to ensure employees who manufacture Carbon Black are not in a working environment where they are at risk of inhaling unsafe doses of Carbon Black in its raw form.^[10]The highest volume use of carbon black is as a reinforcing filler in rubber products, especially tires. While a pure gum vulcanization of styrene-butadiene has a tensile strength of no more than 2.5 MPa, and almost nonexistent abrasion resistance, compounding it with 50% of its weight of carbon black improves its tensile strength and wear resistance. It is used often in the Aerospace industry in elastomers for aircraft vibration control components such as engine mounts.

1. APPLICATION OF CARBON BLACK

Carbon black is a basic material with a long history, and it has been used as a coloring agent since the days before Christ. Since carbon black has nano-particles with various functions such as ultra-violet absorption and conductivity, it is still being applied to new fields such as electronic equipment and devices. Some applications of carbon black, which is a conventional yet new material, are shown below.

1) COLORING AGENT FOR INK AND PAINTS:-

Carbon black has higher tinting strength compared to iron black or organic pigments, and is widely used for newspaper inks, printing inks, India inks, and paints. Carbon black is also used as black pigment for inkjet ink or toners.

2) RESIN AND FILM COLORING AGENTS:-

Carbon black has high tinting strength and is thermally stable, and therefore it is suitable for coloring resins and films that are heat-formed. Carbon black is also excellent for absorbing ultraviolet light, providing both a superb resistance against ultraviolet rays and a coloring effect when just a small amount is mixed with resins. Carbon black is widely used for general coloring for resins and films. Resins with carbon black are used in automobile bumpers, wire coverings and steel pipe linings which require weather resistance in particular.

3) ELECTRIC CONDUCTIVE AGENT:-

Carbon black particles have the graphite-type crystalline structure, providing an excellent electric conductivity. Therefore, carbon black is widely used as conductive filler, being mixed in plastics, elastomer, paints, adhesives, films, and pastes. Fuel caps and fuel-introducing pipes of automobiles, for example, are required of electric conductivity for preventing static. Therefore, carbon black is used as an excellent antistatic agent.

4) ELECTRONIC EQUIPMENT RELATED

Material:-Carbon black also provides stable resistance, and therefore is used as electronic equipment related material in various display components, magnetic recording materials, and OA rolls. Furthermore, Mitsubishi Chemical has been developing carbon black with various combined functions for special applications.

1.2 .SUBSTANCE IDENTIFICATION

Synonyms:- Channel black, furnace black, thermal black.

Appearance and odor;- Odorless black solid

1.3.CHEMICAL AND PHYSICAL PROPERTIES

Physical data

1. Specific gravity (water=1: 1.8 to 2.18
2. Vapor pressure at 20⁰c:-Essentially zero

4.REACTIVITY

1. Incompatibilities:- Contact with strong oxidizers(chlorates, bromates and nitrates) may causes fires and explosions.

2. Hazardous decomposition product:- Toxic vapors and gases(i.e. carbon monoxides) may be released in a fire involving carbon black.

3. Caution:- Carbon black dust may form explosive mixtures in air.

1.4 FLAMMIBILITY

1.Minimum dust ignition temperature 510^oc

WARNING PROPERTIES

1.Evaluation of warning properties for respirator selection(carbon black)

1.5 MANUFACTURING PROCESS;-

Following flow chart show the manufacturing process for carbon black.

GRADE DETAILS:-

Activated carbon is an inert material with porous structure.It is broadly classified on the basis of the following two application.

Activated carbon is an inert material with porous structure.It is broadly classified on the basis of the following two application.

1. Those use for adsorption of gases and vapours(granular and material)
2. Those used for the purification of liquid(usually powder materials) Activated carbon can be manufactured from wood, coconut shell.

Activated carbon can be produced from any carbonaceous material which on activation attain porous structure and consequently a large surface area.Raw material such as wood,, coconut shell used for the manufactured of Activated carbons.Raw materials having high carbon and low ash contents are preferred.Coconut shell has been found to be most suitable raw material for making gas adsorption grade.The shell char is actiavated with direct steam and fired with liquid fuel in temperature of 1000 to 2000 deg. Cent. In specially designed rotary kiln in controlled condition to obtain granualated carbon

FLOW PROCESS

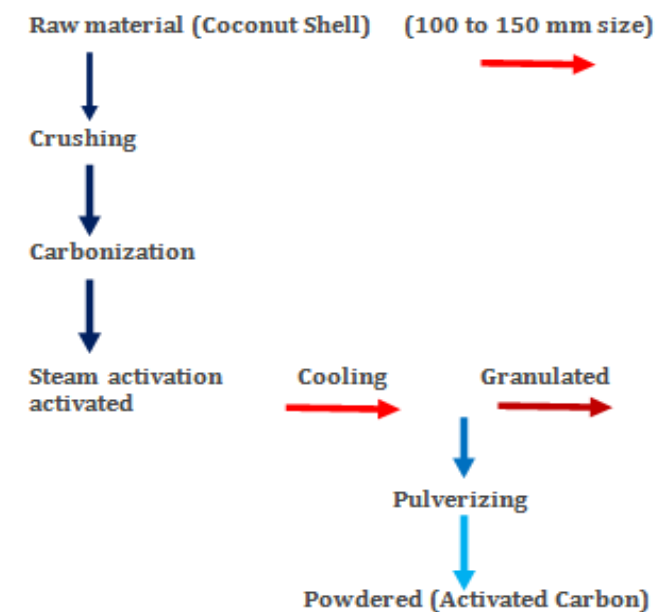

1.6 SCOPE FOR FUTURE WORK





CARBON BRUSH

A brush is a device which conducts current between stationary wires and moving parts, most commonly in a rotating shaft. Typical applications include electric motors, alternators, and electric generators.

1.7 MANUFACTURING PROCESS

MIXING COMPONENTS

Exact composition of the brush depends on the application. Graphite/carbon powder is commonly used. Copper is used for better conductance (rare for AC applications and not on automotive fuel pumps which run on carbon commutators). Binders, mostly phenol- or other resins or pitch, are mixed in so the powder holds its shape when compacted. Other additives include metal powders, and solid lubricants like MoS_2 , WS_2 . Much know-how and research is needed in order to define a brush grade mixture for each application or motor.

COMPACTING THE MIXTURE

The brush compound is compacted in a tool consisting of upper and lower punch and die, on mechanical or hydraulic presses. In this step, depending on later processing, the copper-wire (called shunt wire) can be inserted automatically through a hole in the upper punch and fixed into the pressed brush block by the powder pressed around. After this process, the brush is still very fragile and in professional jargon called a 'green brush'.

FIRING OF GREEN BRUSHES

Next follows heat treatment of the "green brushes" under artificial atmosphere (usually hydrogen and nitrogen). Temperatures range up to 1200°C . This process is called sintering or baking. During sintering, the binders either burn off or carbonize and form a crystalline structure between the carbon, copper and other additives. Baking is followed by graphitization (heat treatment). The heat treatment is transformed by a temperature curve exactly defined for each material mixture. Besides the mixture composition, the used temperature curve is the second big "secret" of each brush manufacturer. After the heat treatment, the brush structure is modified in a way which makes copying of the brush nearly impossible for competing companies.

SECONDARY OPERATIONS

Sintering causes the brushes to shrink and to bend. They must be ground to net shape. Some companies use additional treatments in order to make the brush more durable by methods such as impregnation of the running surface by special oils, resins and grease.

Manufacturing of carbon brushes requires an in-depth knowledge of materials and experience in mixture compositions. Very small changes in brush contents by just a few percent of components by weight can significantly change the properties of brushes on their applications. There are just a handful of brush developing companies in the world, which are mostly specialized on certain types of brushes. Carbon brushes are one of the least costly parts in an electric motor. On the other hand, they usually are the key part which delivers the durability ("life-time") and performance to the motor they are used in. Their production requires very high attention to quality control and production process control throughout all steps of the production process. A carbon brush is a sliding contact used to transmit electric current from a static to a rotating part in a motor or generator, and as regards DC machine, ensures a spark-free communication.

A carbon brush can be

1. Made of one or more carbon blocks
2. Equipped with one or more shunts/terminals.

A carbon brush friction coefficient μ has to be low and stable over time to allow the carbon brush to work without overheating.

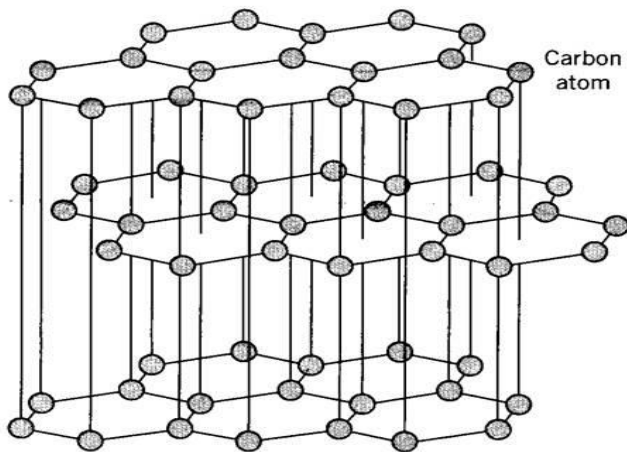

Figure 1: Carbon Black Particle Size Comparison

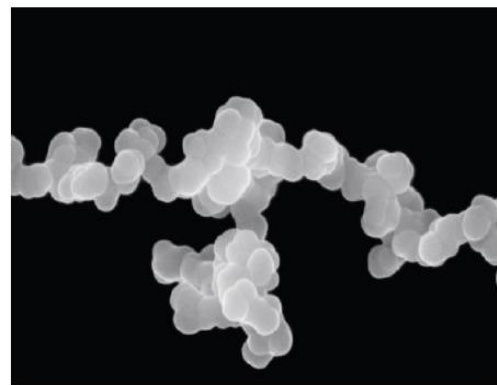
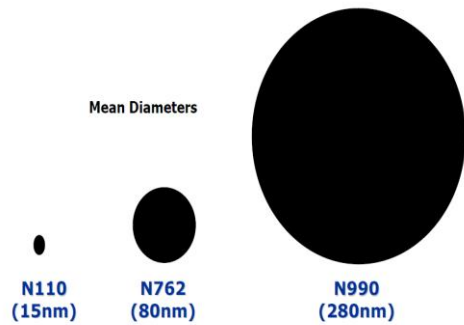
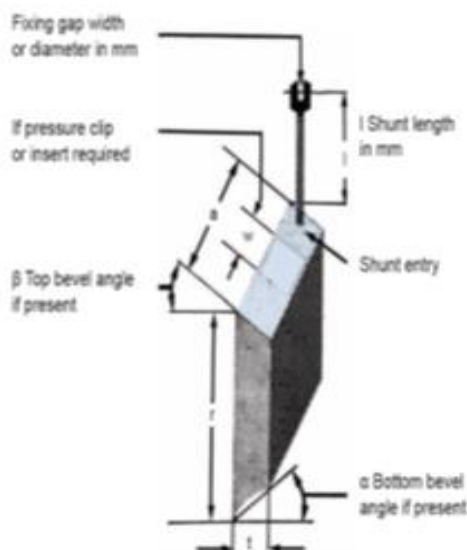

Figure 1b: Scanning electron microscope view of a typical carbon Black aggregate consisting of fused primary particles (magnification: x 120,000)

Essential information for the manufacture of a carbon brush



ACKNOWLEDGMENT

We acknowledge with a deep sense of gratitude, the encouragement received from researcher and scientist of various Institute of Technology for undertaking this work. Credit to a great measure also goes to goes to our colleagues in various universities and Engineering colleges across the country for motivating us and providing useful information of this research paper. We will welcome any suggestion or addition which can be incorporated in this

paper for making it more useful to researchers, engineers and students in future.

2. CONCLUSION

This paper show the manufacturing process of the carbon black powder from coconut shell .This papers also show the importance of Carbon black for manufacturing of carbon brush which is very vital for conduction of electricity, electric generators. Here by using various type of ingredients we have to investigate the real characteristic of carbon brush and its proprety. Our future study could be useful for the new innovative work for carbon powder and carbon brush.

My future result could be application orientated of carbon black.

1] Carbon are the main elements to absorb the unwanted electromagnetic wave.

2] Besides the mixture composition, the used temperature curve is the second big Secret of each brush manufacturer.

3] Its commercial material which exist in hard [Diamond] and soft form.[Graphite]

REFERENCES

Numerous papers have been published on carbon black. We recommend the following which provide comprehensive information

1. Carbon Black- Second edition Revised and Expanded. Donnet, JB. Bansal RC Wang. MJ Marcel Dekker Inc New York 1993
2. Carbon Black vs black carbon and other air bone materials containing elements carbon; Physical and Chemical distinction.Long Ch. M Nascarella M.A. and Vallberg P.A. Environment pollution Volume 181. October 2013 pages 271-286
3. Particle characteristic in the reactor and pellitizing areas of" carbon black production" Kuhiusch T.A.J. and Fissan H. 2006 , 3(10) 558-567

BIOGRAPHY:



Asst. Prof. Rahul G. Karmankar
Area of Intrest-Heat Transfer,
Carbon Black