

“Design and Analysis of fluid flow in AISI 1008 Steel reduction gear box”

J.Suryam Yadav¹, Dr.G.Sathyanarayana Reddy²

¹Master of Technology (CAD/CAM)

² Professor, Dept. of Mechanical Engineering,

Sreenidhi Institute of Science and Technology College, Autonomous, Hyderabad, Telangana, India

Abstract: In present situation we are founding problems in industries that are in casting. Now a day's industries are saving money and time to manufacturing products because there is much of competition in world industries. Coming to research the main aim of the project is redesigned the product in FEM analysis using commercial software and increase the product life. Many of the researchers considered that 90% of the defects shows in the casting that is solidification time and shrinkage and hotspots, due to the mis-run and improper filling and gating and risering these are the problems and only 10% is manufacturing problems in industries. To minimize defects in casting systems based on the CAD simulation and analysis in simulation technology with the goal to improve the casting quality. Therefore in this dissertation optimize the results in present based on the CTIA and simulation technology. Design a model in CATIA to pat design and convert in casting model. After analysis simulation results shrinkage and solidification and hotspots system is used to improve the casting quality. In these reduction gear box is used to verify effectiveness to optimize the method. Comparison with previous model simulation process is used to solve the problems and the simulated results are compared with experimental work

Key words: casting design, shrinkage porosity, hotspots, and solidification time.

I - INTRODUCTION

Casting is one of the oldest and cheapest methods of producing parts of desired shape. It is defined as the shaping of a material in liquid state. In casting the liquid metal is poured in mould cavity, usually made of sand, and allowed to solidify. After complete solidification the part is removed from mould either by breaking or separating the two parts of a mould. The part obtained by casting is called casting. The process takes advantages of molten metal to conform the form of the mould into which it is poured and it is possible to produce the castings ranging in size from few grams to more than hundred tons. Casting in various forms represents one of the most important metals shaping process used in engineering manufacturing

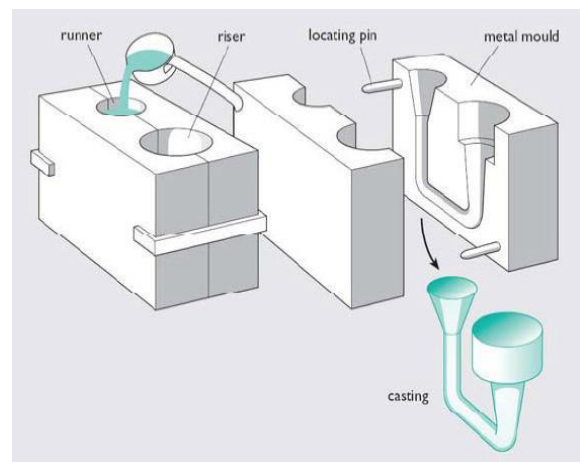

Fig: Casting

CLASSIFICATION:

Metal casting processes are classified, according to the type of mould used in two types:

➤ Expendable mould casting

Sand casting, shell moulding, and investment casting ZORILI M2

➤ Permanent mould casting

Gravity dies casting, pressure die casting, and centrifugal casting

Porosity in sand casting:

Sand castings are used to manufacture shapes. In casting metals several factors have to be considered in order to reduce the defects in casting. The defects may rise from one or more of the following reasons.

- Poor melting and pouring practices
- Poor mould and pattern design
- Poor quality of moulding sand

Many defects are common to all casting process. Some defects arise due to improper mould construction and poor quality of sand. They occur only in sand casting. If they found some defects after casting it will be rejected.

Need for Defect Prediction:

Now days foundry engineers are decided to optimize geometric casting design and they selected good parameters that to eliminate the shrinkage and some more defects. As an experiment results it is very difficult to eliminate shrinkage porosity completely from casting.

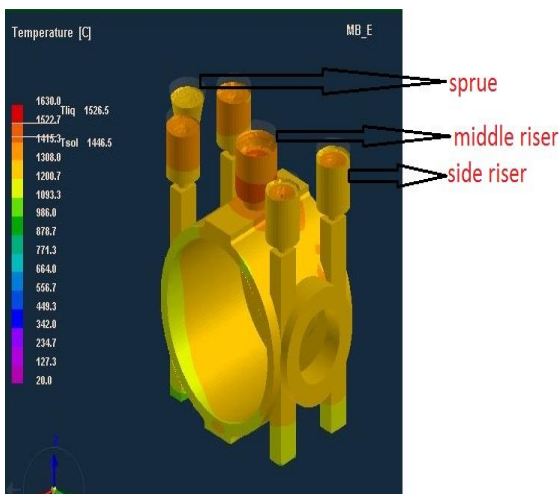

Gating/riser system design and optimization.

After pouring metal, it will flow through the gating system until the cavity is fully filled. Then the metal begins to cool and solidify with the occurrence of shrinkage. Riser system is designed to compensate such shrinkage. Gating/riser system has great effects on the final quality of casting. A foundry can produce the best quality moulds, cores and molten steel and still end up with a poor quality casting by using poorly designed gating and riser systems. So how to design a satisfied gating/ riser system is very important.

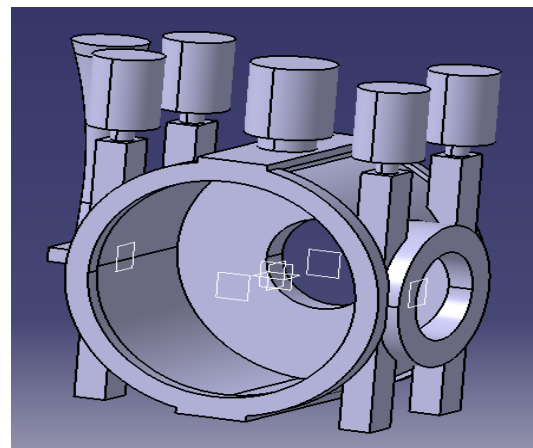

Fig: Reduction gear box

Sand casting processes

Sand casting consists of placing a pattern (having the shape of the desired casting) in sand to make an imprint, incorporating a gating system, filling the resulting cavity with molten metal, allowing the metal to cool until it solidifies. Sand casting is still the most popular form of casting. The steps to make sand castings are illustrated in Fig.

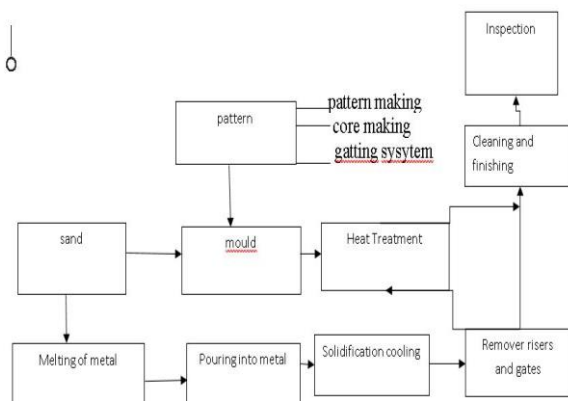

Fig Production steps in a typical sand casting processes

Design of risers

❖ **Middle Riser:**

- Diameter =90
- Radius = 45
- Height =100
- Volume = $\pi (45)^2 (100)$
 $6,36,429\text{mm}^3$
- Curved surface area = $2\pi (45) (100)$
 $=28274.33\text{mm}^2$
- Total surface area = $2\pi rh + 2\pi r^2$

$$2\pi r (h+r)$$

$$2\pi (45) (100+45)$$

$$40997.78\text{mm}^2$$

Four Risers:

- Diameter=74
- Radius = 37
- Height =100
- Volume = $\pi (37)^2 (100)$

=430084.0343mm²

- Curved Surface area = $2\pi (37) (100)$

= 23247.78²

- Total Surface area = $2\pi r h + 2\pi r^2$
 $= 2\pi r^2 (h+r) = 2\pi (37) (100+37)$
 $= 3184.466\text{mm}^2$

Riser Neck:

- Diameter =25
- Radius = 12.5
- Height = 20
- Volume = $(12.5)^2 (20) = 9817.477\text{mm}^3$

Curved Surface Area = $2\pi (12.5) (20)$
 $= 1570.79\text{mm}^2$

- ❖ Total surface Area = $2\pi r (h+r)$
 $= 2\pi (12.5) (20+12.5) = 2552.544\text{mm}^2$

main parts: Pre-processing: the program reads the CAD geometry and generates the mesh, Main processing: adding of boundary conditions and material data, filling and temperature calculations, Post processing: presentation, evaluation. Casting simulation package requires three dimensional CAD model for the simulation purpose. CAD model should be Designed with gating and reserving system. Computer simulation based on the design procedures described above have been implemented with one case study.

II-Methodology:

Numerical simulation method is used to solving the problems fro engineering and mathematical physics. It is also considered as FEM. Numerical simulation is very important tool because any one can use it to find out facts and to study the process in that way because another tool cannot accomplish. It is one of the best ways to analysis the process to solidify.

These paper is simulated for the solidification of sand castings for the gear box to analysis the results to optimize the riser and gating parameters to get better results for sand casting.

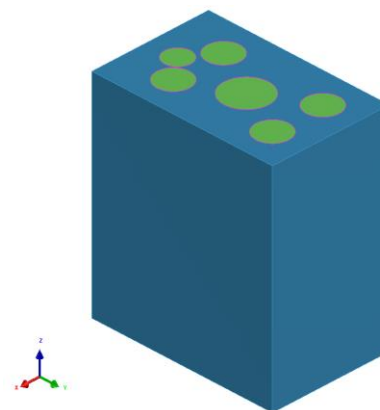

Fig: Mold box

Simulation of CATIA model

The well design CATIA model of the Reduction gear box was simulated using casting simulation software. The sequence of stages for simulation using commercial software

Modeling process

This Modeling can be done with the help of CATIA software and can be inserted in Numerical simulation based software using geometry transformation. In this numerical simulation based software, model generation means of nodes that generates the volume. Modeling consists of defending two types one is sand mold and other one is casting with proper dimensions. Generally the simulation software has three

Casting	Low carbon (steel AISI 1008)
Material Molding Material	Silica sand
Pouring Temperature	1550°C
Mold Temperature	30°C
Chill	Copper

TABLE I: Input Parameters for Casting Simulation

3D Modeling ⇌ Meshing with mesh cast ⇌ Data input cast ⇌ Calculation

Analyzing result in view cast

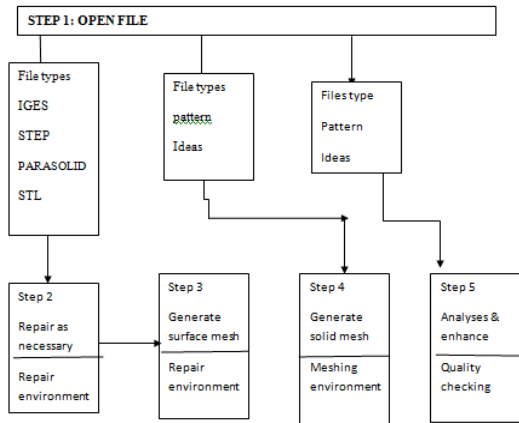

Wrok flow

Flow chart: Shows FEM analysis

TABLE II: Gating and Risering Parameters

	Diameter	Height(mm)
Left & Right Risers	7.5mm	13.9mm
Center Riser	8.7mm	13.9mm
One spure	8.5mm	36.5mm
Total length of the body	34.5mm	
Neck diameter	2.5mm	20mm

Table III: sphere risers diameter

Sphere risers	Height	Diameter
Side risers	11.447mm	2.50mm
Middle risers	14.05mm	2.504mm

Table IV: Copper chill parameters

	Height	Breadth	Length
Chill-1	30mm	45mm	30mm
	Diameter		
Chill at top circular 2	126mm		
Chill at side circular 2	124mm		

III-Case study:

A case study is conducted to verify the use of Pro-CAST in an industry casting environment. The selected case study is a main body of Reduction Gear box made from low carbon steel by Indy engineering Industries, cherlapally, Ranga Reddy (Dist). The tests is conducted in this case study by Pro-CAST to find defects in the casting at different locations and compare them with the real casting design and to find possible outcomes and modifications attempted to improve the existing casting design. The modification of existing riser and gating design are changed to improve the existing casting design, riser, shrinkage porosity and hotspots and gating systems with improved yield. Composition of casting material is

IV. RESULT AND ANALYSIS:

3D models of the casting has prepared with five risers and one sprue and different gating system by using CATIA software. The different parameters used in casing simulation processes have given in Table 1 and the size of gating and risering parameters of original and modified models are shown in Table 2. Due to the design of taper sprue and unpressurized gating system, the molten metal enters the mould through gate and rises almost uniformly in the cavity of the mould until it has completely filled up. This is a good filling because it ensures no sand erosion in the mould and solidification of liquid metal immediately starts in the mould cavity. By changing the dimension of the riser, the total mould filling time is not much affected.

Option 1(Original)

The input parameters for casting simulation in all cases are same as given in the Table 1 and the size of the risers and sprue and modeling of the casting dimensions has given in Table 2. In model 1, the size of the four risers is 7.5*13.9mm and centre riser is 8.7*13.9mm. Here Figure 5 to Figure 7 shows the simulated results obtained by using FEM based casting simulation of



Fig: 3D CAD model of Reduction Gear box

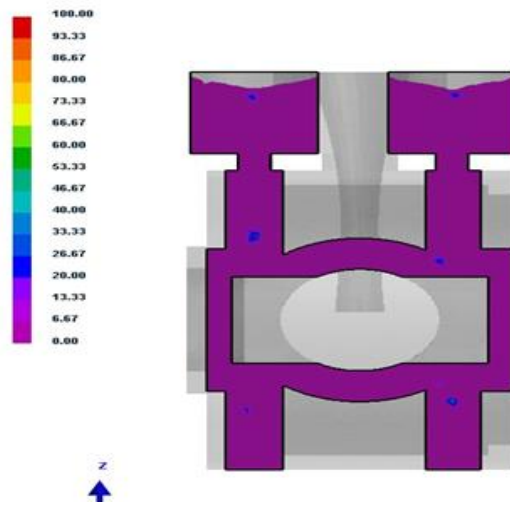

Step 9

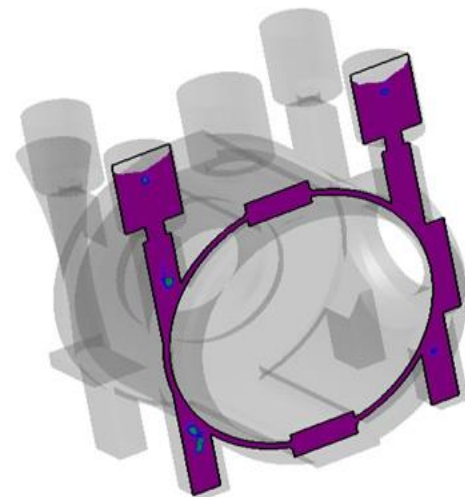
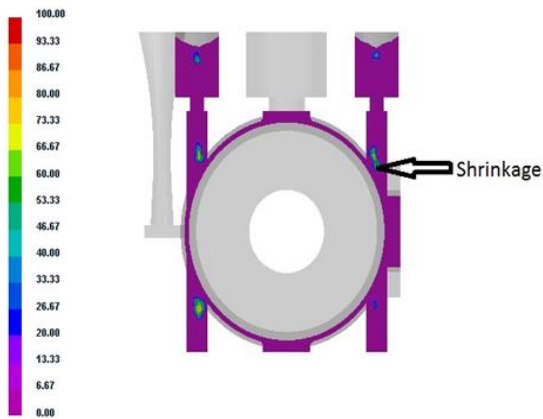

Step 10

Fig: shrinkage porosity



Fig: graphical structure for shrinkage porosity



Fig: Improper filling in step 10

model 1, the simulated results indicated that the shrinkage defect and shrinkage porosity remains in the casting. It also shows step by step variation of temperature distribution. The original casting is shown in Figure 4.

Shrinkage porosity:

Now a days we are seeing more defects in sand casting that is shrinkage porosity. Mostly it is related to shape of the casting is major causes of casting rejections in industry. From scientific view the problem of shrinkage formation is regular and interesting. The thermal properties of the alloy being cast and the geometry of the casting are all important properties for final cast product and it is one of the most important purpose to solidification simulation to avoid shrinkage cavity and hotspots and porosity if they occur for many predictions criteria or method have been proposed as well as such temperature gradient method. Here we are seeing some shrinkage porosity in casting as well as in risers as shown in fig

Hotspots:

In these casting, founded some hotspots in FEM results. Then analysis those things how we have avoided hotspots from casting we try to remove by keeping insulation to risers and applying chills to bottom of four legs and at middle circle they got some results by allying chill

Option 2(Modified)

The input parameters for casting simulation are given in the Table 1 and the size of the risers and sprue and modeling of the casting dimensions has given in Table 2. In model 2, we redesigned sphere risers and the size of side four riser heights is changed to 11.447 mm and riser diameter is changed to 2.50 mm and centre riser height is changed to 14.05mm and diameter is changed to 2.504mm show in table 3.

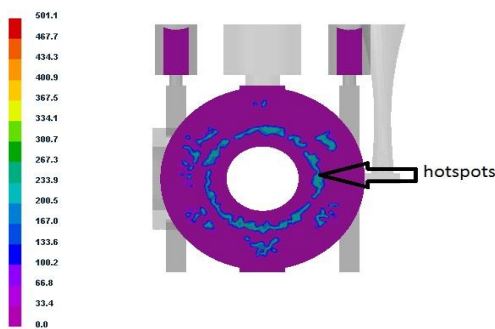

Step 1

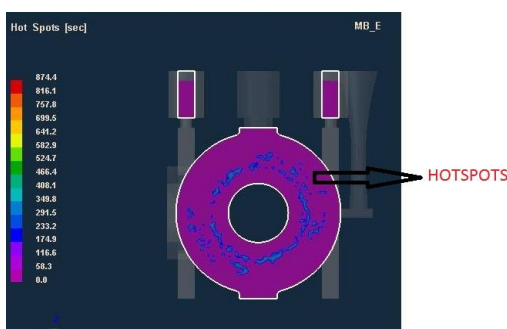

Step 4

Fig: hotspots in original casting

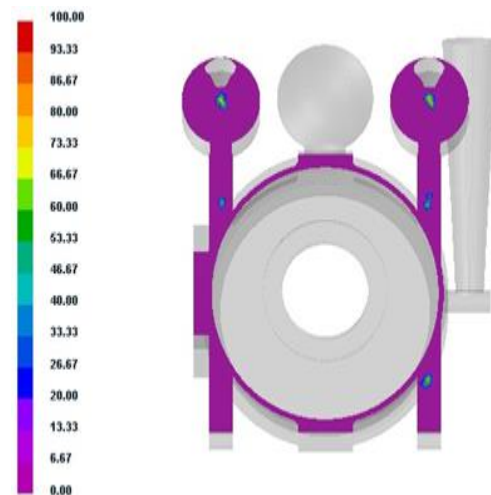

Step: 1

Fig: shrinkage porosity

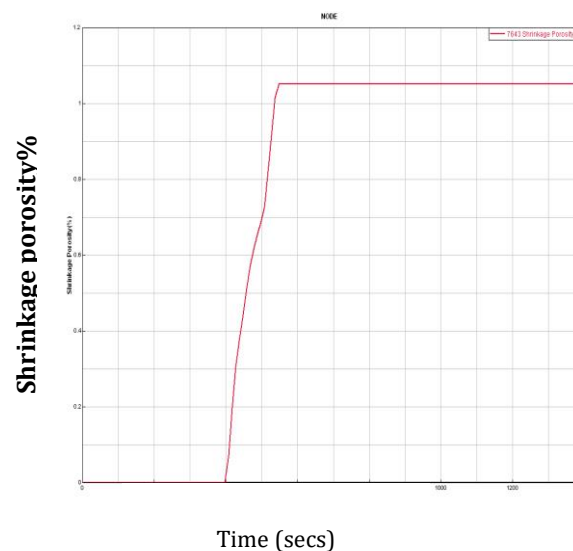

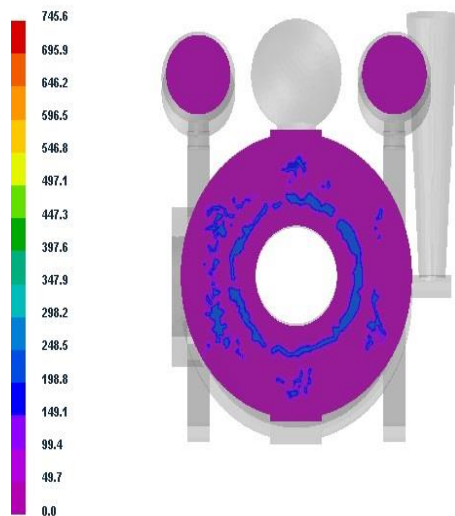

Step 2

Fig: Hotspots

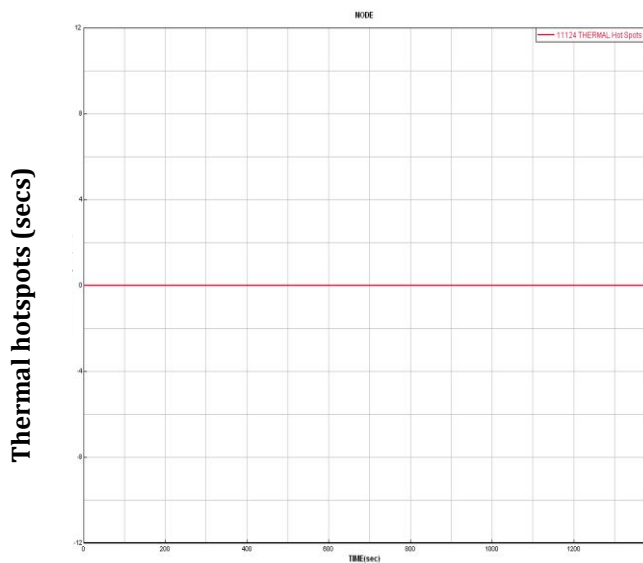

Time secs

Option 3(Modified)

The input parameters for casting simulation are given in the Table 1 and the size of the risers and sprue and modeling of the casting dimensions has given in Table 2. In model 3, the size of side four riser heights is changed to 13.9 mm and riser diameter is changed to 9.5 mm and centre riser height is changed to 13.9 mm and diameter is changed to 11mm and neck diameter 20mm to 2.8mm and insert copper chill at bottom and center circle of the casting shows dimensions in table 4.

Comparison of Result

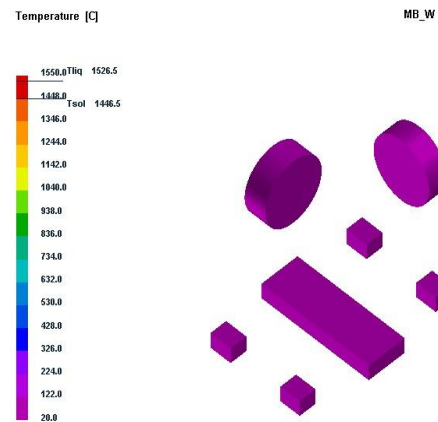

Fig: Copper chill

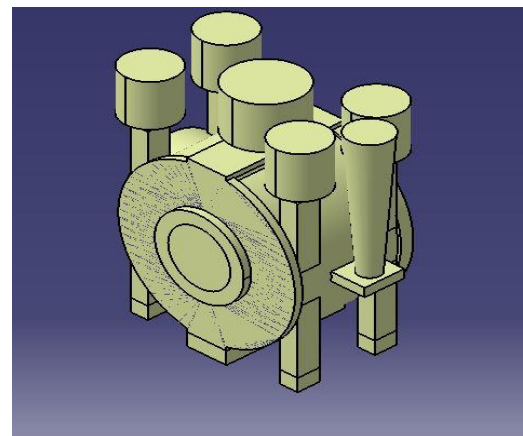
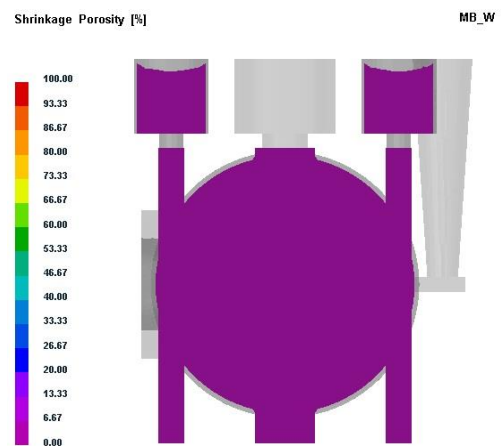

Fig: 3D CAD model Reduction gear box after inserting chills



Step1

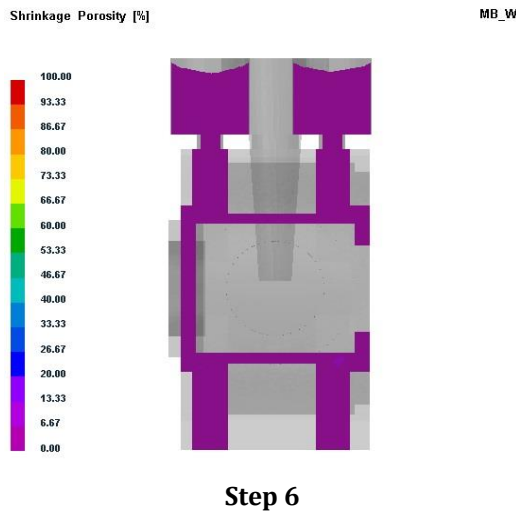

Fig: shrinkage porosity

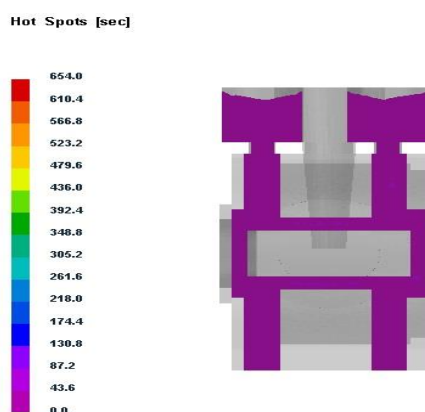
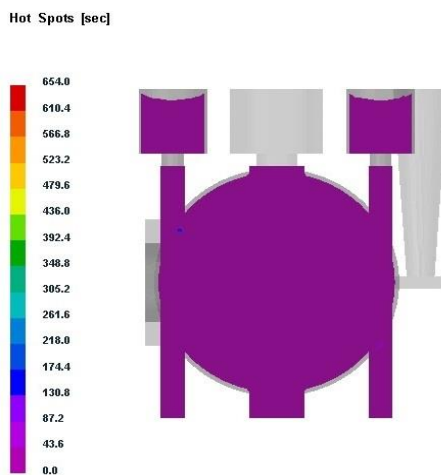

Fig: Hotspots

Here while doing numerical simulation analysis we founded some shrinkage porosity and hotspots .in these simulation those things how to remove the hotspots and shrinkage from casting. Comparison with previous simulations option 1 in step 0 and step 9 shrinkage and hotspots are too high. To remove those defects redesigned the risers cylindrical to sphere risers' shows with dimension in table 3 and step 1 and 2 still we absorb defects in casting. So with that results again inserted cylindrical risers with table 5 dimensions and insert copper chill its parameters shows in table 4 so with that simulation the defects which we absorb in casting is decreases and solidification time is also decrease.

V. CONCLUSIONS:

The developments in the production of castings, computer simulation can be a useful tool for rapid process development.

	Option 1		Option 2	
	Height	Diameter	Height	diameter
Side four risers	13.9*7.5mm		13.9*9.5mm	
Middle riser	13.9*8.7mm		13.9*11mm	
One spure	36.5*8.5mm			
Total dia	34.5mm			
Neck dia	20mm		28mm	

Table V: Comparison of results

Application of casting simulation software in foundries can be able to optimize the size and the position of the risers to avoid shrinkage defect in the casting.

New design has the following improvements:

- The casting simulation software results are matching experimental results.
- Modified design reduces shrinkages porosity defect.
- The casting yield is increased by 8 %.
- The modified casting is clearly a better proposition since it increases productivity while at same time decreasing production costs.

REFERENCES

1] Uday A. Dabade and Rahul C. Bhedasgaonkar, "Defect Analysis using Design of Experiments (DoE) and Computer Aided Casting Simulation Technique Forty Sixth CIRP Conference on Manufacturing Systems," p. 616621,2013.

[2] T. R. Vijay ram, S. Suleiman, A. M. S.vHamouda, M. H. Mahmud, "Numerical simulation of casting solidification in permanent metallic molds, Journal of Materials Processing Technology," p.29-33, 2006.

[3] Maria Jos Marques, (2006). CAE Techniques for Casting Optimization, INEGI, P.4465- 4591. 2.

[4] Rabindra Behera, Kayal, S. Sutradhar. G. (2001). Solidification behavior and detection of Hotspots in Aluminum Alloy castings: Computer Aided Analysis and experimental validation, International Journal of Applied Engineering Research, ISSN 09764259.

[5] Reis, A. Hubert, Y. Zhian Xu, Rob Van Tol, (1999). Modeling of shrinkage defects during solidification of long and short freezing materials, Journal of Materials Processing Technology 95, p. 428-434, 1999