

Deflection of Dual Rotor Wind Turbine Pinion Tooth by Numerical Method

Mr. Dattatray Annasaheb Patil ¹, Prof. Dalwe D.M.², Prof. Morkane N.M.³

¹ P.G. Student, Department of Mechanical Engineering, S.T.B. College of Engineering Tuljapur, Dist. Osmanabad, Maharashtra, India.

² Associate Professor, Department of Mechanical Engineering, S.T.B. COE Tuljapur, Maharashtra, India.

³ Associate Professor, Department of Mechanical Engineering, Sinhgad COE Solapur, Maharashtra, India.

Abstract: A gear is a rotating machine part having cut teeth, which mesh with another toothed part in order to transmit torque. Gears may be spur, helical, bevel or worm in which Spur Gear is most common type of gear used in engineering applications. The increased in performance requirement such as high load carrying capacity, high speed, high reliability and long life leads to new design of gear. These gears should be strong; corrosion resistance light weighted and should be durable for a long time. The bending and surface strength of the gear tooth are considered to be one of the main contributors for the failure of the gear in a gear set. Thus, the analysis of stresses on gears is to minimize or to reduce the failures and for optimal design of gears. This work investigates the characteristics of a spur gear system mainly focused on bending and contact stresses using analytical and finite element analysis. Mating gears of both gear and pinion is taken to be same materials with same size. The model for spur gear and pinion was done in CATIA and stress analysis was carried out using ANSYS. The results obtained from ANSYS are presented in this work.

Key words: Bending and contact stress analysis, Gear deflection, Mesh generation, Spur gear.

1. INTRODUCTION

Gearing is one of the most critical components in a mechanical power transmission system, and in most industrial rotating machinery. It is possible that gears will predominate as the most effective means of transmitting power in future machines due to their high degree of reliability and compactness. In addition, the rapid shift in the industry from heavy industries such as shipbuilding to industries such as automobile manufacture and office automation tools will necessitate a refined application of gear technology.

A gearbox as usually used in the transmission system is also called a speed reducer, gear head, gear reducer etc., which consists of a set of gears, shafts and bearings that are factory mounted in an enclosed lubricated housing.

Speed reducers are available in a broad range of sizes, capacities and speed ratios. Their job is to convert the input

provided by a prime mover (usually an electric motor) into an output with lower speed and correspondingly higher torque. In this analysis of the characteristics of involute spur gears in a wind turbine gearbox was studied using nonlinear FEM.

In the today's world of industrialization Gears are the major means for the mechanical power transmission system, and in most industrial rotating machinery. Because of the high degree of reliability and compactness gears dominates the field of mechanical power transmission. Gearbox is used to convert the input provided by a prime mover into an output required by end application. Due to increasing demand for quiet and long-term power transmission in machines, vehicles, elevators and generators, people are looking for a more precise analysis method of the gear systems. Spur gear is the most basic gear used to transmit power between two parallel shafts with almost 99% efficiency. It requires the better analysis methods for designing highly loaded spur gears for power transmission systems that are both strong and quiet. Due to development of computers people are using numerical approach for the analysis purpose as it can give more accurate analysis results. The finite element method is capable of providing information on contact and bending stresses in gears, along with transmission errors, which can be done easily in ANSYS software. Gear analysis in the past was done by using analytical methods which requires complicated calculations. Now with the use of FEA we can calculate the bending stresses in the gear tooth for given loading condition and we can compare the FEA results with existing models to decide the accuracy. Also static as well as dynamic, both loading conditions of gear can be easily analyzed in Ansys which is not the case with Analytical method.

2. LITERATURE SURVEY

PradeepKumarSingh, ManwendraGautam, GangasagarandShyamBihariLal, [1] "Stress Analysis Spur Gear Design by Using Ansys Workbench" International journal of mechanical engineering and robotics research. ISSN 2278 – 0149, Vol. 3, No. 3, July 2014

Mr. Kishor N. Naik, Prof. Dhananjay Dolas, [3] The main objective of this paper is to analyze the bending stresses

occur on the gear tooth profile of gear used in gear box of special purpose machine also effect on bending stress by variation of the gear parameters. Face width and root radius are taken gear parameters, how stress redistribution are taken place by varying this parameter studied. The stresses are calculated with the help of the FEA this result are compared with the stresses calculated by Lewis equation. For this work parametric modeling is done using Pro-E 5.0 and for analysis ANSYS 12.0 workbench is used. This work helpful to conclude Effect of bending stress on gear tooth profile by variation of gear parameters also give the comparison of FEM method with analytical calculation. Effect of bending stress on gear tooth profile by variation of gear parameters also give the comparison of FEM method with analytical calculation.

Vivek Karaveer, Ashish Mogrekar and T. Preman Reynold Joseph, [4] This paper presents the stress analysis of mating teeth of spur gear to find maximum contact stress in the gear teeth. The results obtained from Finite Element Analysis (FEA) are compared with theoretical Hertzian equation values. For the analysis, steel and grey cast iron are used as the materials of spur gear. The spur gears are sketched, modeled and assembled in ANSYS Design Modeler. As Finite Element Method (FEM) is the easy and accurate technique for stress analysis, FEA is done in finite element software ANSYS 14.5. Also deformation for steel and grey cast iron is obtained as efficiency of the gear depends on its deformation. The results show that the difference between maximum contact stresses obtained from Hertz equation and Finite Element Analysis is very less and it is acceptable.

A gear is a rotating machine part having cut tooth, which mesh with another toothed part in order to transmit torque. Gears are mainly type like spur gears, helical gears, double helical gears, bevel gears, crown gears, hypoid gears, worm gears, rack and pinion, epi cyclic gears etc. rolling mills, hoisting and transmitting machinery, marine engines, Parallel and co-planer shaft connected by gears are known as spur gear.

Utkarsh.M.Desai, Prof.Dhaval.A.Patel, [2] "Modeling And Stress Analysis Of Composite Material For Spur Gear Under Static Loading Condition", Issn (Print):23 6202,(Online):2394-6210,Volume-1,Issue-2,2015.

Spur gear is the simplest & widely used in power transmission system. A spur Gear is generally subjected to bending stress which causes teeth failure. However it is observed that performance of the spur gear is not satisfactory in certain applications and therefore it is required to explore some alternate materials to improve the performance of the spur gears. Composite materials provide adequate strength with weight reduction and they are emerging as a better alternative for replacing metallic gears. In this work, A metallic gear of Alloy Steel is replaced by the composite gear of 30% Glass filled Poly-ether-ether- Ketone

(PEEK). Such Composites material provides much improved mechanical properties such as better strength to weight ratio, more hardness, and hence less chances of failure. In this work, an analysis is made with replacing metallic gear with composite material such as PEEK so as to increase the working life of the gears to improve overall performance of machine. Finally the Modeling of spur gear is carried out using SOLIDWORK and bending stress analysis of spur gear is carried out using ANSYS V14.

Shaik Gulam Abul Hasan, Ganoju Sravan Kumar, Syedaaniya Fatima, [3] "Finite Element Analysis and Fatigue Analysis Of Spur Gear Under Random Loading", International Journal Of Engineering Sciences & Research Technology. ISSN: 2277-9655(I2OR), Publication Impact Factor: 3.785 Every component or structure is designed based on factor of safety. Present analysis is one such analysis of carrying fatigue test on spur gear using software package ANSYS. For this purpose, initially static analysis of the model was carried out to validate the model and the boundary conditions correctness. Further Modal analysis is carried out to determine the dynamic characteristics of the gear model. The present work deals with the calculate ion of static and dynamic analysis, and fatigue life estimation of test gear, which is contacting master gear and assuming loading on the gear is random or constant amplitude by Finite Element package ANSYS. Initially gear system is modeled in CATIA V5 later it is imported into ANSYS for further analysis.

Boštjan Trobentar, Srečko Glodež , Boštjan Zafošnik [4] "Deflection Analysis of Spur Polymer Gear Teeth" Journal of Multidisciplinary Engineering Science and Technology (JMEST) ISSN: 3159-0040 Vol. 2 Issue 4, April - 2015

The presented article describes an investigation regarding the deflection behaviour of polymeric gear transmission using numerical analyses (FEM) and a standardized procedure. A polymer gear pair was modeled and analyzed using ABAQUS software and the numerical results were then compared with the analytical results according to the German norm VDI 2736. In the numerical analyses the gear deflection behaviour is determined using Young's material model and the hyper elastic Marlow model. The computational analyses have shown that the selection of the appropriate FE-model has a significant influence on the accuracy of the numerical results. The numerical analyses also indicated that an appropriate non-linear material model should be considered in the case of higher contact forces, and consequently large deflections.

Joginder Singh, Dr. M R Tyagi (5) "Analysis Of Stresses And Deflections in Spur Gear" International Journal of Mechanical Engineering and Technology (IJMET) Volume 8, Issue 4, April 2017, pp. 461-473 Article ID: IJMET_08_04_050.

Power is generated by various methods. Then it has to be transmitted from one point to another point in a mechanical system or machine by various methods. Gear system is one of the most efficient methods for transmitting power. Gears are used in applications from tiny toys to giant machineries like earth movers. The efficient and reliable performance of an automotive vehicle is very much dependent on the quality of gears and their stress bearing capability. The present work is an attempt to analyze the stresses and total deformation in a spur gear. The analysis is done for the gears with different materials. The torque specifications and dimensions of the gear of three existing models of commercial cars from the Indian market are taken for the study. The analysis is made using ANSYS software. The results of this study are presented in this paper.

3. Methodology

3.1. CAD MODEL

Computer-aided design (CAD), also known as computer aided design and drafting (CADD), is the use of computer technology for the process of design and design documentation. Computer Aided Drafting describes the process of drafting with a computer. CADD software, or environments, provides the user CAD is mainly used for detailed engineering of 3D models and/or 2D drawings of physical components, but it is also used throughout the engineering process from conceptual design and layout of products, through strength and dynamic analysis of assemblies to definition of manufacturing methods of components. It can also be used to design objects.

3.2. CATIA

Computer aided three dimensional interactive application (CATIA) is a software from Dassault systems, a France based company. CATIA delivers innovative technologies for maximum productivity and creativity, from the inception concept to the final product.

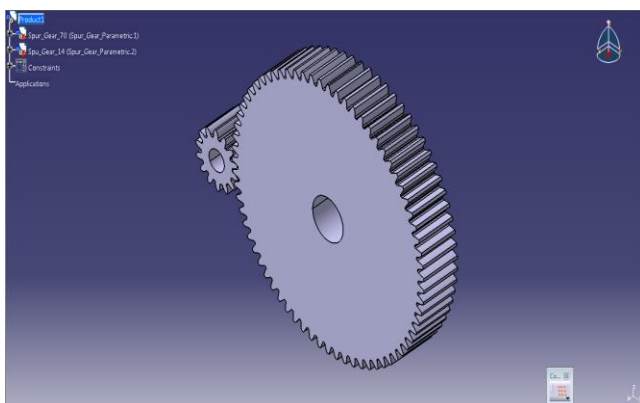

Fig. 1. CAD model of spur gear drawn in CATIAV5

CATIA provides three basic platforms-

- P1 for small and medium sized process oriented companies that wish to grow towards large scale digitized product definition.
- P2 for advanced design engineering companies that require product, process, and resource modeling.
- P3 for high-end design applications and is basically for automotive and aerospace industry, where high quality surfacing is used.

3.3. Finite Element modeling of Pinion gear:

The finite element method (FEM), sometimes referred to as finite element analysis (FEA), is a computational technique used to obtain approximate solutions of boundary value problems in engineering. Simply stated, a boundary value problem is a mathematical problem in which one or more dependent variables must satisfy a differential equation everywhere within a known domain of independent variables and satisfy specific conditions on the boundary of the domain.

Boundary value problems are also sometimes called field problems. The field is the domain of interest and most often represents a physical structure. The field variables are the dependent variables of interest governed by the differential equation. The boundary conditions are the specified values of the field variables (or related variables such as derivatives) on the boundaries of the field. Depending on the type of physical problem being analyzed, the field variables may include physical displacement, temperature, heat flux, and fluid velocity to name only a few.

4. Results and Discussions

4.1. Analytical Result for Pinion

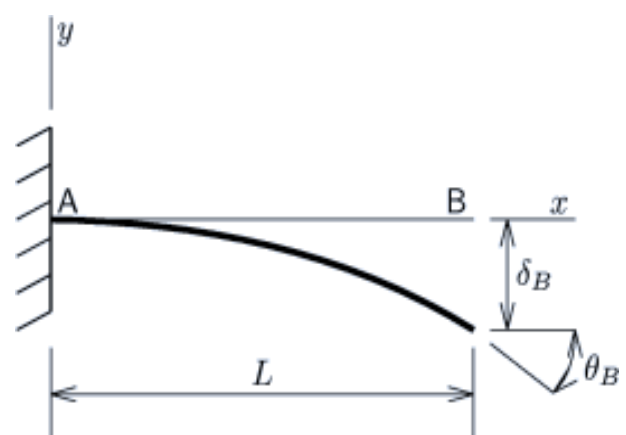
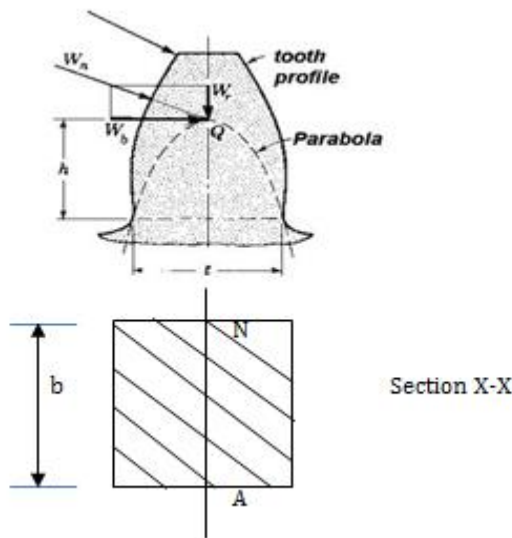

Fig. 2. Slope and deflection of Pinion



1) For Carbon Steel (E = 165 GPa)

Tangential Force $P_t = 1722.83 \text{ N}$

Module ,m = 5 mm

Pitch Circle Dia. Of Pinion $d_p = 84 \text{ mm}$

Pitch Circle Dia. Of Gear $d_g = 420 \text{ mm}$

Face Width $b = 10 \text{ m} = 10 * 5 = 50 \text{ mm}$

Tooth Thickness ,t = $1.5708\text{m} = 1.5708 * 5$
 $= 7.854 \text{ mm}$

Moment of Inertia $I = bt^3 / 12$
 $= 50 * (7.854)^3 / 12$
 $= 2018.65 \text{ mm}^4$

For the Pinion Circle Dia. $d_{ap} = d_p + 2m$
 $= 84 + 2 * 5$
 $= 94 \text{ mm}$

Root Circle Dia. $d_{fp} = d_p - 2.5m = 84 - 2.5 * 5$
 $= 71.5 \text{ mm}$

Length $L = h = \text{Addendum} + \text{Dedendum} = m + 1.25 \text{ m}$
 $= 2.25 \text{ m} = 2.25 * 5 = 11.25 \text{ mm}$

Consider a Pinion tooth as a cantilever Beam with tangential force at free end, therefore max. Slope and deflection is obtained at free end as shown in above fig.

i) Max. slope at free end B

$$\theta_B = P_t L^2 / 2EI = 1722.83 * (11.25)^2 / 2 * 165 * 10^3 * 2018.65$$

$$= 0.000328 \text{ rad.}$$

ii) Max. deflection at free end B

$$Y = P_t L^3 / 3EI$$

$$= 1722.83 * (11.2)^3 / 3 * 130 * 10^3 * 2018.65$$

$$= 0.0031 \text{ mm (} \blacktriangledown \text{)}$$

2. For Glass Fiber (E = 200 GPa)

Tangential Force $P_t = 1722.83 \text{ N}$

Module ,m = 5 mm

Pitch Circle Dia. Of Pinion $d_p = 70 \text{ mm}$

Pitch Circle Dia. Of Gear $d_g = 420 \text{ mm}$

Face Width $b = 10 \text{ m} = 10 * 3.5 = 35 \text{ mm}$

Tooth Thickness ,t = $1.5708\text{m} = 1.5708 * 5$
 $= 7.854 \text{ mm}$

Moment of Inertia $I = bt^3 / 12$
 $= 50 * (7.854)^3 / 12$
 $= 2018.65 \text{ mm}^4$

For the Pinion Circle Dia. $d_{ap} = d_p + 2m$
 $= 84 + 2 * 5$
 $= 94 \text{ mm}$

Root Circle Dia. $d_{fp} = d_p - 2.5m = 94 - 2.5 * 5$
 $= 81.5 \text{ mm}$

Length $L = h = \text{Addendum} + \text{Dedendum} = m + 1.25 \text{ m}$
 $= 2.25 \text{ m} = 2.25 * 5 = 11.25 \text{ mm}$

Consider a Pinion tooth as a cantilever Beam with tangential force at free end, therefore max. Slope and deflection is obtained at free end as shown in above fig.

i) Max. slope at free end B

$$\theta_B = P_t L^2 / 2EI = 1722.83 * (11.25)^2 / 2 * 200 * 10^3 * 2018.65$$

$$= 0.000269 \text{ rad.}$$

ii) Max. deflection at free end B

$$Y = P_t L^3 / 3EI$$

$$= 1722.83 * (11.25)^3 / 3 * 200 * 10^3 * 2018.65$$

$$= 0.0020 \text{ mm (} \blacktriangledown \text{)}$$

4.2 Ansys Result

A. Deflection Results for Carbon Steel

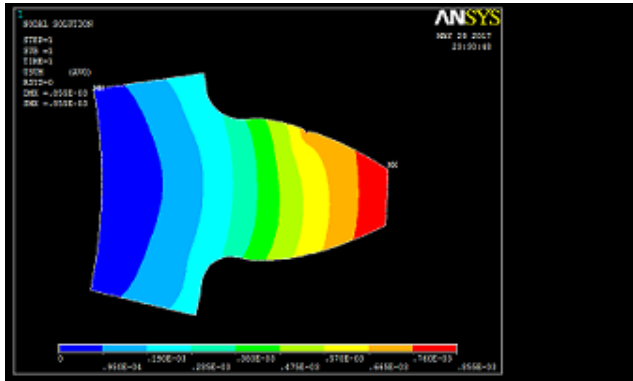

Fig.3. Deflection 0.0855 mm at load 1722.83 N (Carbon Steel)

B. Deflection Results for Glass Fiber

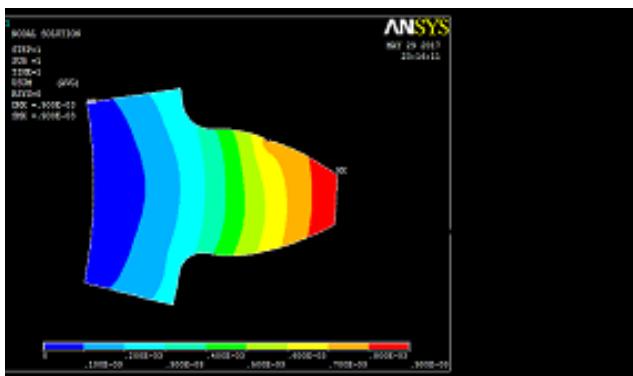

Fig. 4 Deflection 0.900 mm at laod 1722.83 N (Glass Fiber)

From the above Ansys result of deformation of spur gear tooth for the Carbon steel and Glass Fiber material deformation is almost same so that much influences is not produces on the tooth of spur gear by replacing the alternative material.

5. RESULT VALIDATION

Table . Comparison of FEA and Analytical Result

Sr. No.	Material	FEA Deflection Result	Analytical Deflection Result
1	Carbon Steel	0.855 mm	0.0031 mm
2	Glass Fiber	0.900 mm	0.0020 mm

6. Conclusions

- In this study, we have analyzed the pinion gear tooth of dual rotor wind turbine by using composite material as a glass fiber for the pinion, we have Analyzed gear pinion tooth deflection numerically and this result is compared with Ansys teeth deflection result.

- We have calculated deflection of pinion tooth deflection by the analytical method for the carbon steel and glass fiber.

- We have compared the Ansys result and numerical result of both materials for the deflection.

- From the above Result table we concludes results of the both material found almost same so there is no influences found by replacement of pinion alternative material on the performance of pinion.

- We can use glass fiber as a alternative material for the design of gear box of dual rotor turbine.

REFERENCES

- [1] Pradeep Kumar Singh, ManwendraGautam, Gangasagar and ShyamBihariLal, "Stress Analysis Spur Gear Design By Using Ansys Workbench" International journal of mechanical engineering and robotics research. ISSN 2278 – 0149, Vol. 3, No. 3, July 2014.
- [2] Utkarsh.M.Desai, Prof.Dhaval.A.Patel, "Modeling And Stress Analysis Of Composite Material For Spur Gear Under Static Loading Condition", Issn(Print):2394-6202,(Online):2394-6210,Volume-1,Issue-2,2015.
- [3] ShaikGulamAbulHasan, GanojuSravan Kumar, SyedaSaniya Fatima, "Finite Element Analysis And Fatigue Analysis Of Spur Gear Under Random Loading", International Journal Of Engineering Sciences & Research Technology. ISSN: 2277-9655 (I2OR), Publication Impact Factor: 3.785.
- [4] Boštjan Trobentar, Srečko Glodež, Boštjan Zafošnik "Deflection Analysis of Spur Polymer Gear Teeth" Journal of Multidisciplinary Engineering Science and Technology (JMEST) ISSN: 3159-0040 Vol. 2 Issue 4, April – 2015.
- [5] Joginder Singh, Dr. M R Tyagi (5) "Analysis Of Stresses And Deflections in Spur Gear" International Journal of Mechanical Engineering and Technology (IJMET) Volume 8, Issue 4, April 2017, pp. 461–473 Article ID: IJMET_08_04_050.

- [6] Mr. Dattatray A. Patil, Prof. Dalwe D.M. "Design and weight optimization of pinion by using FEA Method International Research Journal Of Engineering and Technology (IRJET)e- ISSN:2395 p- ISSN: 2395 0072 Volume: 04 Issue: 06 June2017.
- [7] Utkarsh.M.Desai, Prof.Dhaval.A.Patel, "Modeling and Stress Analysis Of Composite Material For Spur Gear UnderStatic Loading Condition", Issn(Print):2394-6202,(Online):2394-6210,Volume-1,Issue-2,2015.
- [8] Mrs. C.M. Meenakshi, Akash Kumar, ApoorvaPriyadarshi, Digant Kumar Dash and Hare Krishna, "Analysis of Spur Gear Using Finite Element Analysis", Middle-East Journal of Scientific Research 12 (12): 1672-1674, 2012, ISSN 1990-9233.
- [9] Mahesh. Badithe, SrimanthulaSrikanth, JithendraBodapalli, "Stress and Reduction Analysis of a Spur Gear Tooth", International Journal of Emerging Technology and Advanced Engineering (ISSN 2250-2459, ISO 9001:2008 Certified Journal, Volume 4, Issue 3, March 2014)
- [10] DevikantBaviskar, BalbheemKamanna, GauriTembe, KajalJuikar, "Design and Analysis of Polymer PEK Spur Gear under Static Loading Condition using FEA"International Journal of Engineering and Advanced Technology (IJEAT) ISSN: 2249 – 8958, Volume-5 Issue-3 February 2016.