

Short Range Radar System using Arduino Uno

Akshay Bochare¹, Mukesh Saini²

¹M.Tech Student, Patel Institute of Engineering & Science, Bhopal, M.P, India

²Assistant Professor, Patel College of Science & Technology, Bhopal, M.P, India

Abstract - Radio Detection and Ranging (RADAR) is a device which is used for monitoring a particular area 24/7. The basic needs of these are security. RADAR is an object detecting device. It can be used to detect aircraft, spacecraft, missiles, vehicles, weather formation and so on. Radar is an addition to man's sensory equipment which affords genuinely new facilities. It consists of Trans-receiver and Processor. RADAR can be of many types. Ultrasonic RADAR is an object detecting system which is used to monitor an area of short range. This system consists of an Arduino which is interfaced to an Ultrasonic Sensor mounted on a Servo Motor. This system is programmed using embedded C, and the result is observed on MATLAB platform.

Key Words: MATLAB Simulink for Arduino, Arduino UNO, Servo Motor

1. INTRODUCTION

Radar is an object-detection system that uses radio waves to determine the range, angle, or velocity of objects. It can be used to detect aircraft, ships, spacecraft, guided missiles, motor vehicles, weather formations, and terrain. This project gives sufficient knowledge of Arduino, MATLAB Simulink for Arduino and mechanics. Servos are small but powerful motors that can be used in a multitude of products ranging from toy helicopters to robots. In this project we are using the Ultrasonic Sensor for operate by emitting a burst of sound waves in very rapid succession. These sound waves hit the intended target, bounce back to the sensor, and travel at known speed. An ultrasonic sensor, radar is much less affected by temperature, improving consistency and accuracy.

Radar was developed secretly for military use by several nations in the period before and during World War II. The term RADAR was coined in 1940 by the United States Navy as an acronym for Radio Detection and Ranging.

Radar can track storm systems, because precipitation reflects electromagnetic fields at certain frequencies. Radar can also render precise maps. Radar systems are widely used in air traffic control, air craft navigation and marine navigation. United States and four commonwealth countries: Australia, Canada, New Zealand and south Africa also developed their own radar systems.

2. SYSTEM ARCHITECTURE

Fig shows the block diagram of Short range radar system.

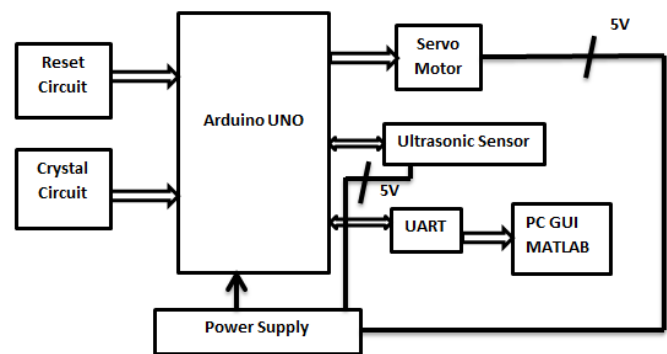

Fig-1 Block diagram of the short range radar

2.1 BLOCK DIAGRAM DESCRIPTION

The above fig.1 shows the Block Diagram of the short range radar system. Here we use Arduino Uno microcontroller which is open source to implement embedded based system. ATMEGA 328 microcontroller send 10 micro second pulse width to ultrasonic transmitter, echo back signal receive by TX module of ultrasonic. After then receive pulse width calculated by micro controller. Here we use servo motor on which ultrasonic module is mounted for receive 180 degree signal.

Microcontroller and MATLAB communicated through UART protocol with the baud rate of 9600. This protocol work on ASCII value. So calculated distance transmit from microcontroller to MATLAB COM PORT. According sensing different obstacle which are around 180 degree and 250 cm range, visible as a red spot on MATLAB GUI.

2.1.1 ARDUINO UNO

The Arduino Uno is a microcontroller board based on the ATmega328. It has 32k Byte in system programmable flash, 14 digital I/O pins (of which 6 can be used as PWM outputs), 6 analog inputs, a 16 MHz ceramic resonator, a USB connection, a power jack and a reset button. Arduino is an open-source platform used for constructing and programing

of electronics. It can receive and send information to most devices, and even through the internet to command the specific electronic device. It uses a hardware called Arduino Uno circuit board. It contains everything needed to support the microcontroller; simply connect it to a computer with a USB cable or power it with a AC-to-DC adapter or battery to get started. "Uno" means one in Italian and is named to mark the upcoming release of Arduino 1.0. The Uno and version 1.0 will be the reference versions of Arduino, moving forward. The Uno is the latest in a series of USB Arduino boards.

2.1.2 ULTRASONIC SENSOR

Ultrasonic sensors are based on the measurement of the properties of acoustic waves with frequencies above the human audible range often at roughly 40kHz. Three different properties of the received echo pulse may be evaluated for different sensing Purposes: 1)Time of flight, 2)Doppler shift, 3)Amplitude attenuation. Ultrasonic ranging module HC-SR04 provides 2cm-400cm non-contact measurement function, the ranging accuracy can reach to 3mm. The modules includes ultrasonic transmitters, receiver and control circuit. The ultrasonic sensor works using trigger and echo method. The transceiver module triggers and sends the signal to the water the water sends back an echo signal which is read by the echo i.e. the receiver module. The Ultrasonic sensor calculated distance of the signal and returns the level of the water. The travel time value and the speed value allow the sensor to calculate the level of the water. The figure below is the image of the ultrasonic sensor used in the project.

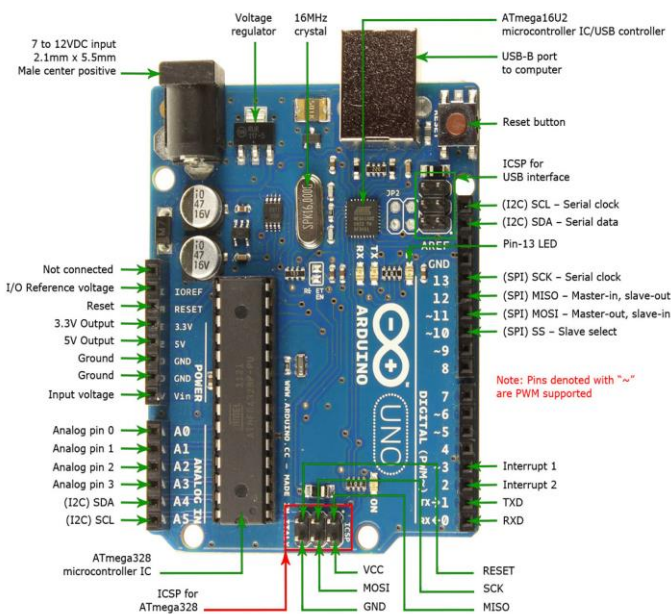

Fig -2: Arduino board

Table -1: Arduino board specifications

Input Voltage (recommended)	7-12V
Input Voltage (limit)	6-20V
Digital I/O Pins	54 (of which 15 provide PWM output)
Operating Voltage	5V
Analog Input Pins	16
DC Current per I/O Pin	20 mA
DC Current for 3.3V Pin	50 mA
Flash Memory	32KB (ATmega328P)
SRAM	2 KB (ATmega328P)
EEPROM	1 KB (ATmega328P)
Clock Speed	16 MHz
Length	101.52 mm
Width	68.6 mm
Weight	25 g



Fig -3: Ultrasonic Sensor

Table -2: Ultrasonic sensor specifications

Power Supply	+5V DC
Working Current	15mA
Effectual Angle	<15°
Ranging Distance	2cm – 400 cm/1" –
Resolution	0.3 cm
Measuring Angle	30 degree
Trigger Input Pulse	10uS
Dimension	45mm x 20mm x

2.1.3 SERVO MOTOR

A servo motor is an electrical device which can push or rotate an object with great precision. If you want to rotate and object at some specific angles or distance, then you use servo motor. It is just made up of simple motor which run

through servo mechanism. Servo Motor is a rotary actuator or linear actuator that allows for precise control of angular or linear position, velocity and acceleration.

Servos are controlled by sending an electrical pulse of variable width, or pulse width modulation [PWM] through the control wire.

Servo motors have three wires: power, ground, and signal. If motor is used is DC powered then it is called DC servo motor, and if it is AC powered motor then it is called AC servo motor. The position of servo motor is decided by electrical pulse and its circuitry is placed beside the motor.



Fig -3: Servo Motor

2.1.4 ZIGBEE

ZigBee is a new wireless technology guided by IEEE 802.15.4. It is currently operates 2.4GHZ in worldwide at a maximum data rate up to 250kbps. One of the major advantages is provide noise free for communication. There are three different devices: (1) ZigBee coordinator node, (2) The full function devices FFD, (3) The reduced function device RFD. ZigBee provides the ability to run for years on inexpensive batteries for a host of monitoring and control applications. The ZigBee network layer ensures that networks remain operable in the conditions of a constantly changing quality between communication nodes.



Fig -4: ZigBee

Table -2: ZigBee specifications

Power supply	Years
Distance	50-1600m
Complicity	Simple
Transmission Speed	256kbps
Frequency Range	915MHZ (US),
Network Nodes	65535
DC Current for 3.3V	50 mA
Power Output	1-100mW
Frequency Hopping	Direct Spread
Security	128bit

3. FLOW CHART

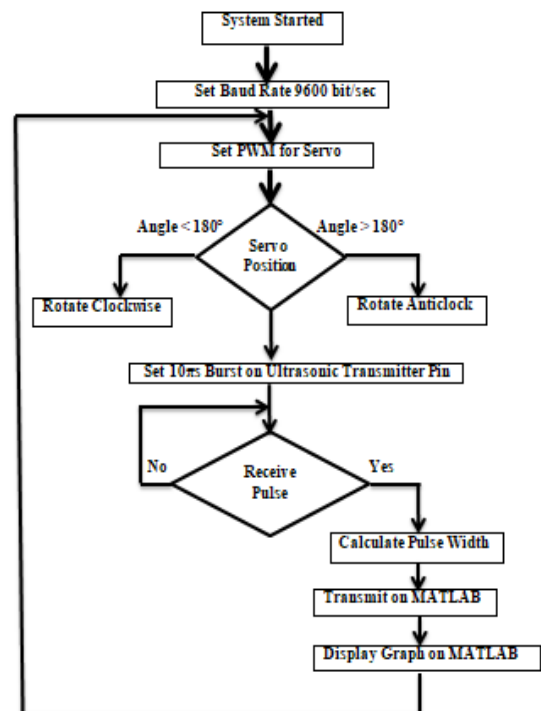

Fig -5: Flowchart of Hardware System

First, we set the baud rate 9600 to communicate with the MATLAB. Here we are mounting ultrasonic module on the servo motor which rotate 180° from clockwise to anti-clockwise direction for this we set. PWM for servo motor. After than choosing the timer we are sending 10µs pulse width on ultrasonic TX pin. Now RX echo pulse width calculates by Arduino Uno microcontroller. After than the real time distance passing for MATLAB terminal at 9600 baud rate. This distance display on MATLAB through graphical geo.

4. HARDWARE RESULT

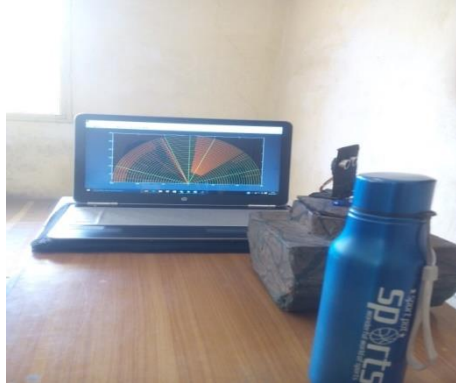

Fig -6: Result of Hardware

5. CONCLUSION

We have represented a project on Ultrasonic RADAR for security system for human or object interference in a short range. The system has been successfully implemented and the aim is achieved without any deviation. There is a lot of future scope of this project because of its security capacity. It can be used in many applications. This project can also be developed or modified according to the rising needs and demand.

REFERENCES

- [1] Gangaram Bhor, Pratik Bhandari, Rahul Ghodekar, Sushant Deshmukh, "Mini Radar", e-ISSN: 2330-8163, March-2016
- [2] Yusuf Abdullahi Badamasi, "The Working Principle Of An Arduino", 978-1-4799-4106-3/14, © 2014 IEEE
- [3] <http://radartutorial.en> (intro, principle of operation)
- [4] <http://microcontrollerslab.com/servo-motor-control-and-interfacing-with-arduino>
- [5] <https://en.wikipedia.org>
- [6] <http://robotforpro.blogspot.in> (sensor)
- [7] Nikhil Kawade, Shaguftah Mulla, Gayatri Mahale, Rohit Mahapure, 'Intrusion Detection and Identification in Water Distribution Network", Vol:4, Issue: 4, April: 2017
- [8] <https://www.jlab.org/ir/MITSeries/V1-1.pdf>