

Study of Ball Valve and Design of Thickness of Shell and Flange

AKSHAY CHOUGUL¹, Prof. RAMESH KATTI²

¹M.Tech Student (Design Engineering), KLE Dr. M S Sheshgiri College of Engineering and Technology, Belagavi, Karnataka, India

²Professor, Department of Mechanical Engineering, KLE Dr. M S Sheshgiri College of Engineering and Technology, Belagavi, Karnataka, India

Abstract - Ball valves are widely used industrial fittings for the construction of oil and gas products transportation facilities (piping systems). They are quarter-turned (90 degrees), straight through flow valves having a round closure element with complementing rounded seats, which permits uniform sealing stress. The type of seat can vary according to the valve pressure rating and materials of construction. To design the ball valve shell and flange for a pressure 35 bar. CAD modeling of Ball Valve Shell & Flange design is made by means of CATIA V5 computer program Static analysis of the Ball Valve Shell body and Flange design is performed using ANSYS 14.5 to find the highest safe stress for equivalent payload/pressure

Key Words: Ball valves, ball valve shell, flange, safe stress

1. INTRODUCTION

Valves are mechanical devices particularly intended to stop, start, blend, coordinate, or control the stream, temperature or pressure of fluid in a piping system. They are designed to handle either gas or liquid application. The operation of valves may be required continuously as in case of control valves, or they may be required to be operated occasionally. The design, application and function of valves arrive in a extensive range of sizes, style and pressure classes, and they can be manufactured from several materials types among which brass, iron, steel, bronze, plastic, or from a number of special alloys.

1.1 Objectives & Scope of Work

The objective of the proposed work is to design and analyze Ball Valve with different pressures for structural strength.

And the scope of this study is for using 20 bar designed ball valve for 35 bar pressure range:

2. Design of Ball Valve Flange and Shell Body Design of Flange for 20 bars (2MPa)

It is designed as per ASME/ANSI standards for design of Pipe Flanges & Flanged Fittings- ASME B16.5.

Material selection:-the material selected A216 WCC from ASTM STD. as a material for flanges as well as for shell.

Material Group (1.2) A216 WCC (C-Mn-Si) (Casting), Material

Properties:-

$$\sigma_{yt} = 275 \text{MPa}$$

$$\sigma_{ut} = 485 \text{MPa}$$

Youngs Modulus (E) = 190 GPa

Poisson Ratio= 0.287

Selection of Flange: From Pressure-Temperature Rating for Flange selection, and hence the selected flange is Class 150 Flange.

Here, the flange specifications from ANSI 16.5 for 150/NB3" Weld-Neck flange for Ball valve.

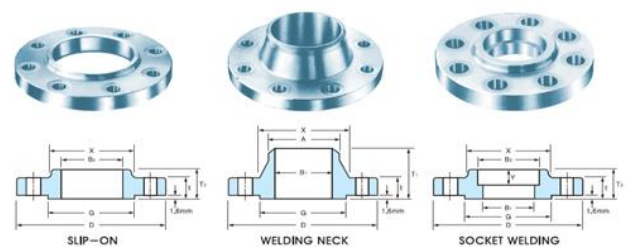

Figure 2.1 Class 150 Flanges

NB	80 mm
OD	191mm
X	108mm
G	127mm
T	23.9mm
B1	78mm
T1	69.9 mm
A	88.9 mm
R	9.7 mm
No. of Bolts	04
PCD	152.4mm

Hole Diameter	19 mm
h ₂ (Neck height)	19 mm

$$\sigma_{yt} = 275\text{MPa}$$

$$\text{Fos} = 04$$

$$\text{Allowable stress } (f) = 68.75\text{MPa}$$

$$\text{Formulae: } t = a \sqrt{\frac{3(3+\mu)P}{8f}} \text{ ----- (eqn 1)}$$

Where, a- Radius of PCD, 76.2mm

μ -Poisson's ratio-0.278,

P-Pressure acting, 20bar

(0.2039Kgf/mm²)

f- Allowable stress, 68.75MPa

(7.0105 Kgf/mm²)

t- Thickness of flange.

Pitch circle diameter measured is 152.4mm

By substituting above values in formulae we get thickness,

$$t = 14.408 \text{ mm}$$

Selected Flange thickness is $t = 23.9\text{mm} > 14.4 \text{ mm}$.

Design is safe.

Design of Shell for 20 bars (2MPa)

The design as per ASME/ANSI standards for design of pipe Flanges & ASME B16.5

Material Properties:-

$$\sigma_{yt} = 275\text{MPa}$$

$$\sigma_{ut} = 485\text{MPa}$$

Young's Modulus (E) = 190 GPa

Poisson Ratio= 0.278

Design of shell:-

$$\sigma_{yt} = 275\text{MPa}$$

$$\text{FoS} = 04$$

$$\text{Allowable stress} = 68.75\text{MPa}$$

$$E = 190\text{GPa}$$

$$P = 20\text{Bar (2MPa)}$$

$$d = 78\text{mm (Flange ID and Cylindrical Shell end ID)}$$

$$D = 106\text{mm (Spherical Shell ID)}$$

For spherical shell, Hoop stress is;

$$t = \frac{p \times D}{4 \times \sigma_t} \text{ ----- (eqn 2)}$$

$$t_1 = 0.77\text{mm}$$

But, it is an open shell with a cylindrical end,

So, we apply Bernie's Principle,

$$t = \frac{d}{2} \times \left[\left\{ \frac{\sigma_t + (1 - \vartheta) \times p}{\sigma_t - (1 + \vartheta) \times p} \right\}^{0.5} - 1 \right] \text{ ----- (eqn 3)}$$

$$t_2 = 1.161 \text{ mm}$$

The cylindrical end thickness= 5.45mm to align with flange neck thickness.

And shell body thickness as 8mm including corrosion allowance as 3mm.

$t = 8\text{mm} > t_1 \ \& \ t_2$, Hence Design is safe.

Where, P - Working pressure = 2MPa (0.2039 kg-f/mm²),

D - Maximum inner diameter of shell-106 mm,

Constant - 3.7 (constant of material)

Allowable stress (f) = 68.75MPa

$$\text{Formulae: } t = \frac{P \times D + 4 \times f \times 3.7 + 0.8 \times P \times 3.7}{4 \times f - 0.2 \times P} \text{ --- (eqn 4)}$$

$$t_3 = 4.4988 \text{ mm}$$

$$\text{So, } t \ \& \ t_2 > t_3$$

So, the selected shell thickness as 8mm and cylindrical end thickness as 5.45mm.

Requirement

Check above designed Ball Valve for 35 bar pressure of water through a pipe of NB=3" (80mm) at 25°C. Given data shall be same only pressure has been increased,

Design of Flange for P = 35bar (3.5MPa):

Where, a- Radius of PCD, 76.2mm

μ -Poisson's ratio-0.278,

P-Pressure acting, =3.5MPa (0.3569Kgf/mm²)

f- Allowable stress, 68.75MPa

(7.0105 Kgf/mm²)

t- Thickness of flange.

By substituting above values in eqn 1 we get thickness,

$$t = 19.0622\text{mm}$$

Selected Flange thickness is $t = 23.9\text{mm} > 14.4 \text{ mm}$.

Design is safe.

But, as per Pipe Flange & Flanged Fitting - ASME B16.5, For pressure above 19.8 bar 150 flanges cannot be used. Pressure-Temperature Rating, select Class 300 Flange with NB=80mm

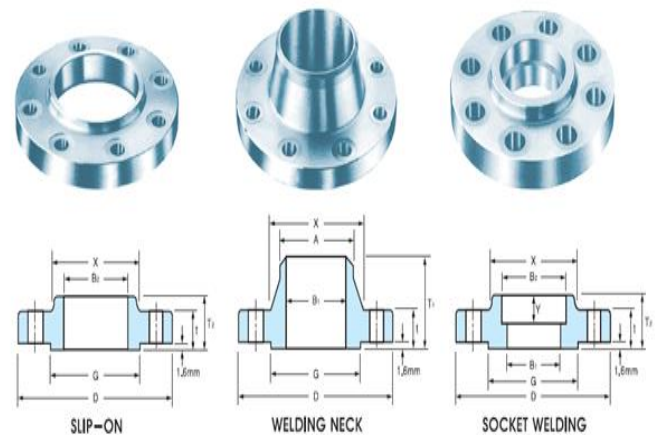

Class 300 Flanges

NB	80 mm
OD	210mm
X	117mm
G	127mm
T	28.4mm
B1	78mm
T1	79.2mm
A	88.9 mm
R	9.7 mm
No. of Bolts	08
PCD	168 mm
Hole Diameter	22 mm
h ₂ (Neck height)	19 mm

$\sigma_{yt} = 275\text{MPa}$

FoS = 04

Allowable stress (f) = 68.75MPa

Where, a- Radius of PCD, 84mm

μ -Poisson's ratio-0.278,

P-Pressure acting, 35bar

(0.3569Kgf/mm²)

f- Allowable stress, 68.75MPa

(7.0105Kgf/mm²)

t- Thickness of flange.

Pitch circle diameter measured is 168 mm.

By substituting above values in eqn 1 we get thickness,

t = 21.013 mm

Selected Flange thickness is t = 28.4mm > 21.013 mm.

Design is safe.

Design of Shell for 35 bars (3.5MPa):-

Given:

$\sigma_{yt} = 275\text{MPa}$

FoS = 04

Allowable stress= 68.75MPa

E= 190GPa

P= 35Bar (3.5MPa)

d= 78mm (Flange ID and Cylindrical Shell end ID)

D= 106mm (Spherical Shell ID)

For spherical shell, we know Hoop stress is;

From eqn 2

t₁= 1.349 mm

But, it is an open shell with a cylindrical end,

So, apply Bernie's Principle, from eqn 2

t₂= 2.068 mm

So, make the cylindrical end thickness= 5.45mm to align

with flange neck thickness.

And shell body thickness as 8mm including corrosion allowance as 3mm.

t= 8mm > t₁ & t₂, Hence Design is safe.

Where, P - Working pressure = 3.5MPa

(0.3569 kg-f/mm²),

D - Maximum inner diameter of shell-106 mm,

Constant - 3.7 (constant of material)

Allowable stress (f) = 68.75MPa

From eqn 4,

t₃= 5.099 mm

So, t & t₂ > t₃; hence,

Design is Safe.

The same valve is used for 35bar pressure it has been found that it does not fail. But as per ASME safety norms we have used flange of higher pressure rating that is 300. & no need to change the shell body thickness.

3. Geometry Detail

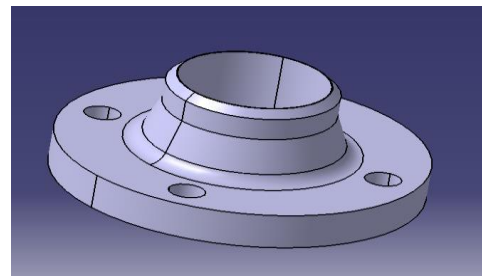

Fig.3.1 Flange 150 NB 3"

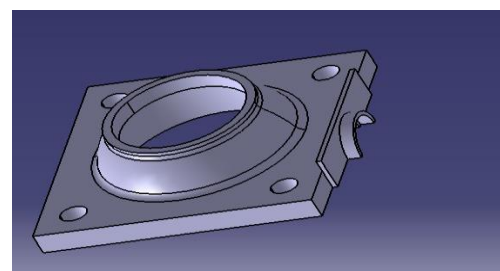

Fig.3.2 Shell Model

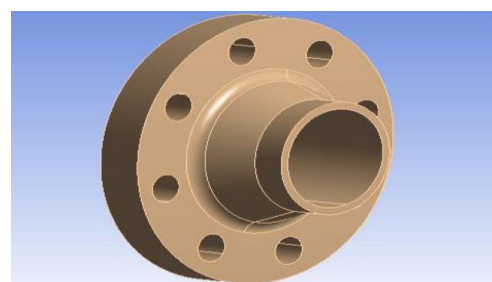

Fig.3.3 Flange 300 model NB 3"

4 Material Properties of Ball Valve

Table 4.1 Material Properties

Properties of Outline Row 4: A216 WCC			
A	B	C	
Property	Value	Unit	
Isotropic Elasticity			
Derive from	Young's Mo...		
Young's Modulus	1.9E+11	Pa	
Poisson's Ratio	0.278		
Bulk Modulus	1.4264E+11	Pa	
Shear Modulus	7.4335E+10	Pa	
Tensile Yield Strength	2.75E+08	Pa	
Tensile Ultimate Strength	4.85E+08	Pa	

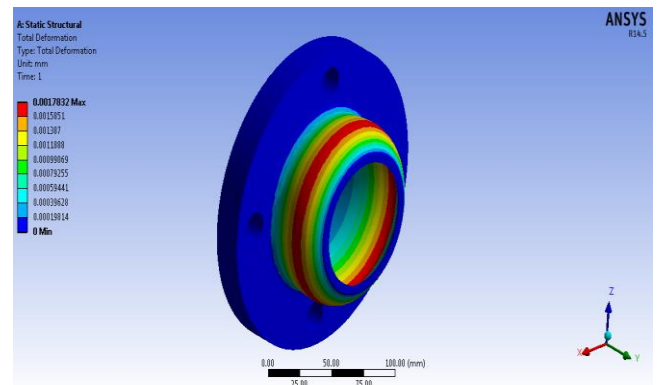

Fig.5.3 Flange 150 Total Deformation for 2MPa

(Pressure=2MPa)

5. Analysis

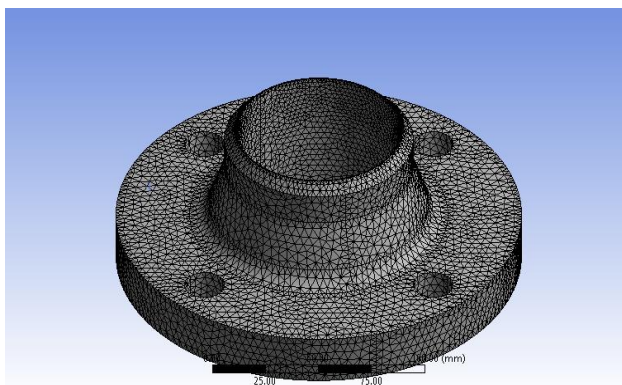

Fig.5.1 Mesh Model of Flange

(Pressure=2MPa)

Von-Mises stress in Shell for 2MPa pressure	14.557MPa
Total deformation in Shell for 2MPa pressure	0.0013204 mm

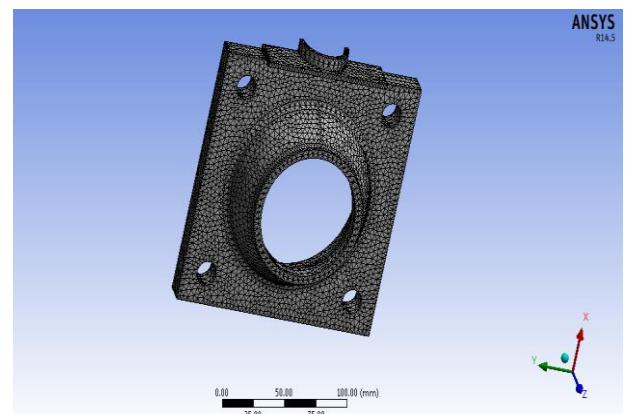

Fig.5.4 Shell Mesh Model

Fig.5.6 Flange 150 Total Deformation for 2MPa

(Pressure=2MPa)

Von-Mises stress in flange for 2MPa pressure	15.782MPa
Total deformation in flange for 2MPa pressure	0.0017832 mm

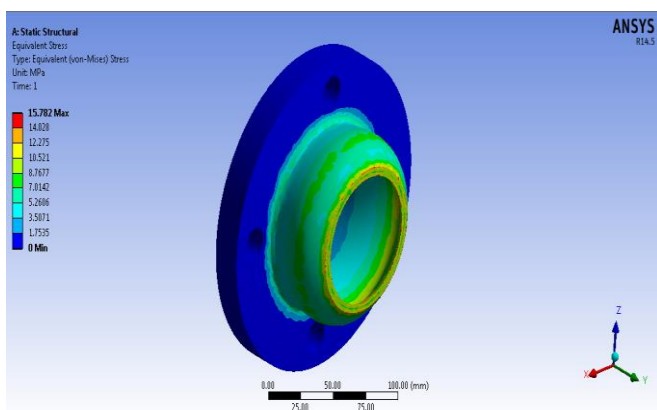

Fig.5.2 Flange 150 von-mises stress for 2MPa

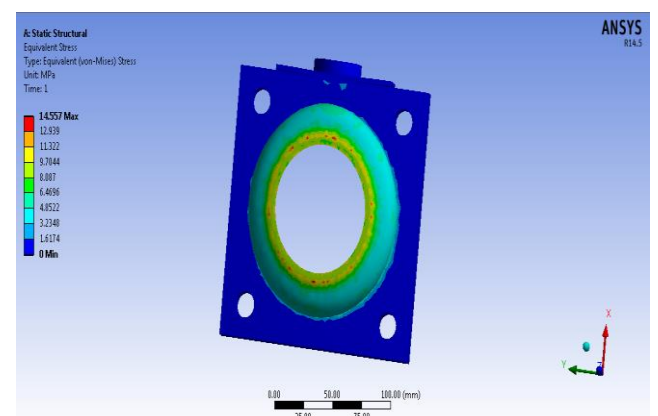

Fig.5.7 Shell Von Mises Stress

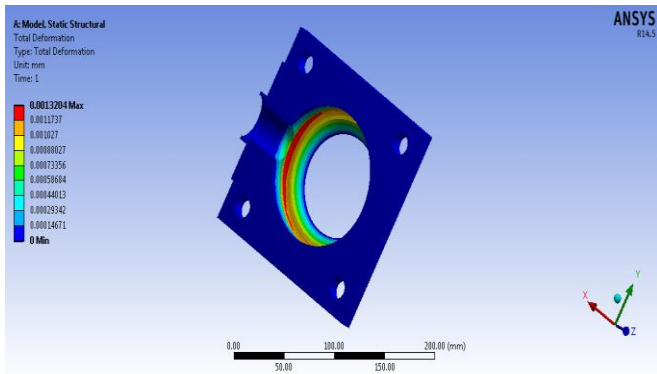

Fig.5.8 Shell Total Deformation

(Pressure=3.5MPa)

Von-Mises stress in flange #300 for 3.5MPa pressure	27.122MPa
Total deformation in flange #300 for 3.5MPa pressure	0.0031233 mm

(Pressure=3.5MPa)

Von-Mises stress in flange for 3.5MPa pressure	27.618MPa
Total deformation in flange for 3.5MPa pressure	0.0031207 mm

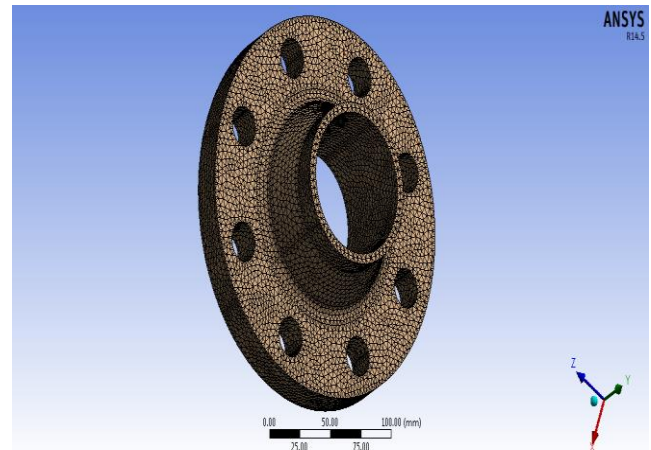

Fig.5.11 Mesh Model of Flange 300

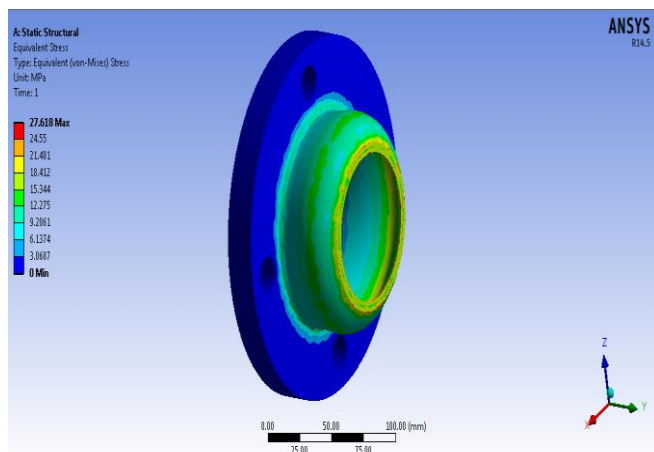

Fig.5.9 Flange 150 Von Mises stress for a load of 35 bar (3.5MPa)

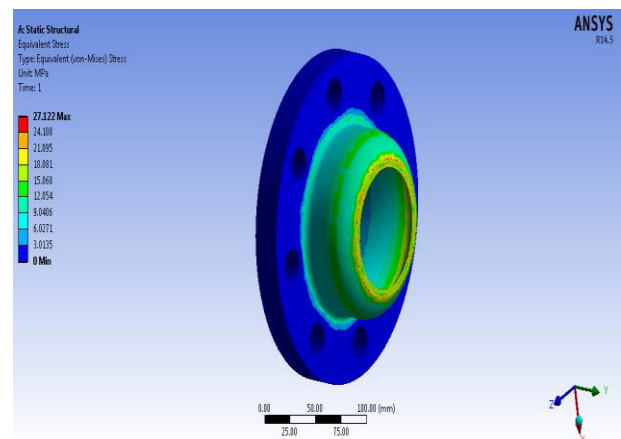

Fig.5.12 Flange 300 Von Mises stress for 3.5MPa

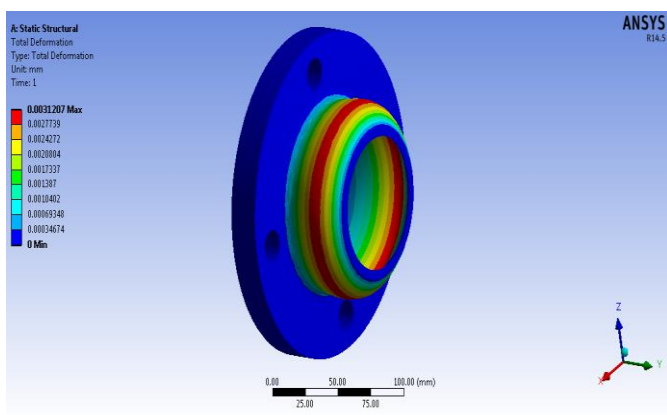

Fig.5.10 Flange 150 Total Deformation for a load of 35 bar (3.5MPa)

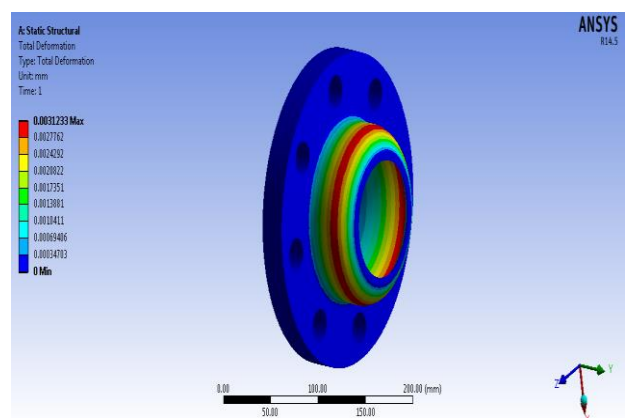

Fig.5.13 Flange 300 Total Deformation for 3.5 Mpa

(Pressure=3.5MPa)

Von-Mises stress in Shell for 3.5 MPa pressure	25.474 MPa
Total deformation in Shell for 3.5 MPa pressure	0.0023107 mm

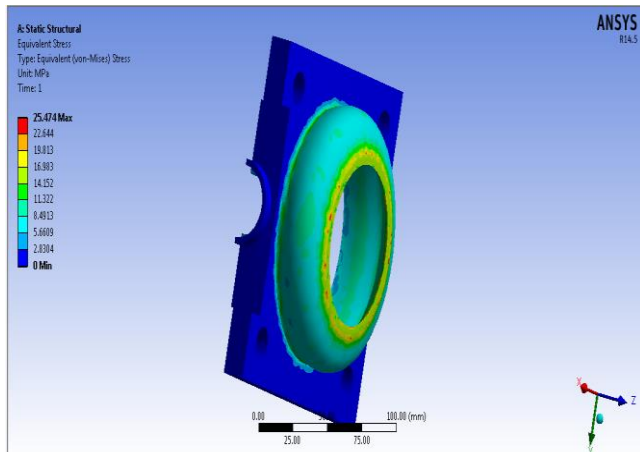

Fig.5.14 Shell Von Mises stress for pressure of 3.5 MPa

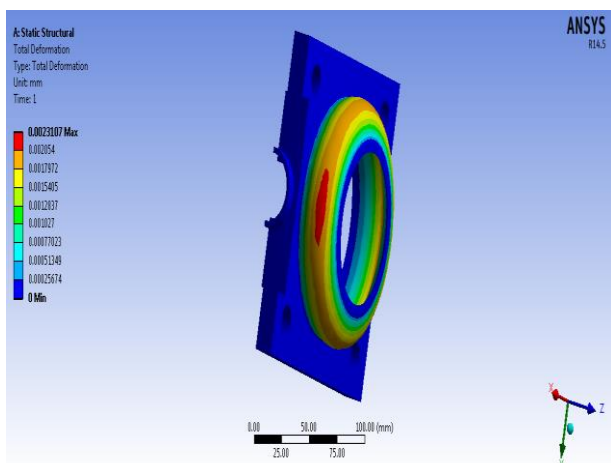

Fig.5.15 Shell Total Deformation for pressure of 3.5 MPa

It has been observed that in none of above cases equivalent/Von-mises stress doesn't exceed the allowable stress limit as 68.75 MPa.

3. CONCLUSIONS

- So, it can be concluded that the design for 20 bars is safe.
- Current designed Ball Valve can also be used for 35 bar pressure.
- As per ASME standard, Flange should be used of class 300 for pressures above 20bars, such as for 35 bars.

- In future, DOE can be done to optimize the mass & other parameter by changing material to composite & changing geometric parameters.
- The cylindrical shell body can also be designed and analysis can be performed in both cases.

REFERENCES

Book

- [1] Khurmi R. S. and Gupta J. K. "Machine Design" first edition; Eurasia Publishing House Private Limited pages (310-315).
- [2] Norton R. L. "Machine Design" third edition; Pearson Education Ltd. pages (454-457,621-624).

Papers

- [1] Ming-Jyh Chern, Chin-Cheng Wang, Chen-Hsuan Ma., performance tests and flow visualisation of ball valves, Journal of experimental thermal and fluid sciences 31(2007)505-512.
- [2] Janusz Rogula.a, The influence of seat fatigue test on the leakage in ball valve, Journal of Procedi Engineering 39(2012)91-97.
- [3] A.Tudor, R.Nehriu, I.Radu, V.Dumitru, A Wear study case of ceramic ball seat valve, Tribology in industry, Volume 25, no 3&4, (2003) 83-88.
- [4] Yogesh G, Dr.Vilas R.K, Vijay M, Modeling and Simulation of valve coefficients and cavitation characteristic in ball valves, Proceeding of the International Conferences on Fluid mechanics and Fluid power December 16-18, 2010.
- [5] Ming-Jyh Chern, Chih-Cheng Wang, Controlling of volumetric flow rate of ball valves by V-ports, journal of fluid engineering may Vol-126(2004), 471-481.
- [6] Ming-Jyh Chern, Chih-Cheng Wang, Effect of control device on flow in ball valve, Transaction of the Aero nautical and Astro nautical Society of the Republic of China.
- [7] Thananchai Leephakpreeda, Design factor for "linear" ball valve, theoretical and experimental study, songklanakarin in J. sci. Technol., 27, (2005), 353-361.