

# A Review Paper on Improving The Efficiency Of Solar Panel

Shaikh Mohamadsaied Rubab<sup>1</sup>, Mulani Saifali Abbas<sup>2</sup>, Shinde Mayur Balasaheb<sup>3</sup>,  
Chaure Balaji Mohan<sup>4</sup>

<sup>1,2,3</sup> Student Of Mechanical engineering, SPVP's S.B. Patil College Of Engineering Vangali, Indapur  
Maharashtra, India

<sup>4</sup> Professor Of Mechanical engineering, SPVP's S.B. Patil College Of Engineering Vangali, Indapur  
Maharashtra, India

\*\*\*

**Abstract** - An operating temperature is governing parameter of solar panel. As temperature of solar panel is increased then efficiency of solar panel decreases. Its means that the operating temperature of PV panel is minimum then maximum efficiency of solar panel maximum is obtained. Various methods are used for solar panel first we have used to Cooling Technique.

**Key Words:** Photovoltaic PV cell , PCM(Phase Change Material),Thermoelectric ,

## 1. INTRODUCTION

An increased need of energy due to demanding by industries, domestic use etc. It could not be fulfilled by only conventional resources. Therefore the demand of alternatively energy resources is also increased. To fulfill this demand solar energy is important energy. Maximum Efficiency of solar panel increased from thermoelectric cooling technique. How apply thermoelectric technique in this we have to see.

## 2. LITRATURE REVIEW

[1] V. jafari fesharaki Majid Dehghani, J.Jafari Fesharaki, Humed Tarasoli, "The effect of temperature of photovoltaic cell efficiency", first international conference on emerging trend in energy conservation-EETEC Tehran, Tehran, Iran. Represented PV characteristics for various Temperatures from these characteristics it can be seen that as the change in Temperature increased it will affect the power output from the cells. Also explained relation formula that gives the effect of temperature of electrical efficiency of PV cell/Module. From this paper we can able to investigate ambient temperature for desired efficiency.

[2]Anna Machniewics, Dominika knera,Dariusz Heim, "Effect of transition temperature on efficiency of PV/PCM", Sixth international building physics conference IBPC 2015 energy procedia 78(2015)1684-1689In this paper the application of Phase Change Material on the back side PV panel helps maintain temperature below the melting point of material. Temperature of PV Panel is every sensitive to climate conditions. The aim of this paper is to investigate and Determine Transition temperature of PCM layer that allows

avoiding rapid temperature fluctuation on the PV back surface.

[3] K.A. Moharram M.S. Abd -Elhaldy, H.a. Kandil, H. El-Sherif,"Enhancing the performance of PV PANELS by water cooling",Ain Shams Engineering Journal(2013)4,869-877. In this paper,an experimental setup has been developed to study the effect of cooling by water On the performance of PV panel.In this paper a Non-pressurised cooling system has been developed which includes spraying the PV Panel by waer.cooling has been developed to find how long it will take to cool the PV Panel by water spray.

[4] Catain George Popovici, Sebastian Veleriu Hudisteanu, Theodor Dorin Mateescu, Nelucristian Chereches,"Efficiency improvement of photovoltaic panels by using air cooled heat simks",sustainable solution for enrgy and enviroment, EENVIR\_YRC 2015,Bucharest,Romana, energy procedia 85(2016)425-432. They represented Dependence between the conversion of efficiency and temperature of PV cell the average reduction of efficiency is about 0.45% for each Degree over the 25 degree Celsius. The efficiency of panel is high,if the oprating temperature of PV panel is in between the range of 18-25 Degree Celsius and above 25 the large impact on efficiency /power output to take place.

[5] Mr. Dinesh S. Borkar,Dr.Sunil V prayagi, Ms. Jayashree Golmare,"Performance Evaluation of Photovoltaic solar panel using Thrmoelectric cooling,International Journal ofEngineering research volume No.3,Issue No.9,pp:536-539. They represented by a effect of solar panel from thermoelectric cooling and without thermoelectric cooling .they said how to avoid the panels heat?how to apply thermoelectric cooling ,it controlled damages efficiency of solar panel .maximum heat is gone to 80 degree Celsius, then not possible to remove heat , the they applied thermoelectric method. Thjen remove heat .life span is increases. ng spelling and grammar:

### 1.1 Photovoltaic Cell

A photovoltaic cell is a p-n semiconductor junction. As light falls on solar panel, a dc current is generated. The equivalent circuit is shown in Fig. 1 which is adopted from [1].

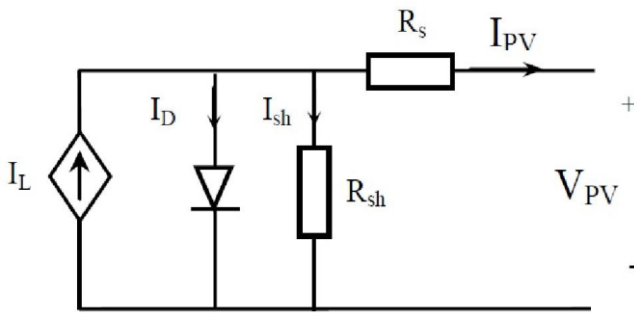

Fig -1: Equivalent circuit of PV-cell [1]

Where,  $I_{pv}$  is the PV module current (A),  $I_0$  is diode saturation current (A),  $I_L$  is the light generated current (A),  $V_{pv}$  is module output voltage (V),  $R_s$  is module series resistance,  $R_{sh}$  is module parallel resistance.

### 1.2 Dependence of Temperature on PV

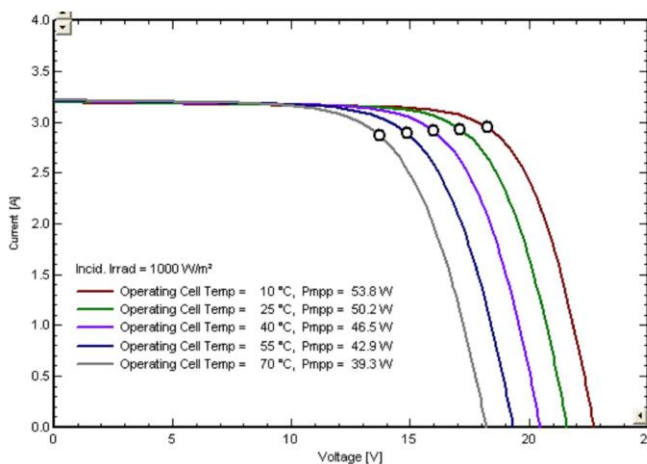

Fig -2: Output I-V characteristics of the PV module at various temperatures [1]

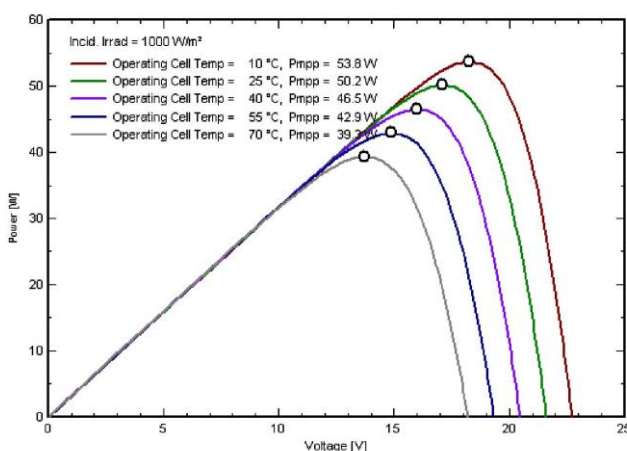

Fig -3: Output P-V characteristics of the PV module at various temperatures [1]

Fig. 2 shows the effect of temperature on I-V characteristics of PV module at constant radiation. With decreasing temperature, PV current decreases slightly but PV voltage increases clearly. As Fig. 3 indicates, P-V characteristics of PV panel in which output power of photovoltaic module increases with decreasing temperature [1]. From these characteristics we can be able to find ambient temperature required to get desired efficiency.

### 2. METHODS USED TO AVOID OVERHEATING EFFECT:

- Use of PCM at the back of PV panel [2],
- Using a setup for water cooling [3],
- Using setup for air cooling [4],
- By Thermoelectric cooling [5],

By the use of above methods we can be able to maintain temperature PV panel at a certain level to achieve desired efficiency.

### 3. CONCLUSIONS

From various papers we concluded that the various aspects are governing the efficiency of solar panel in which temperature of PV panel is one the important aspect. To increase the efficiency of PV cell the PV panel temperature should be maintained at particular level. It is the standard temperature at which photovoltaic cells are designed, and it is different for different PV technologies used.

### ACKNOWLEDGEMENT

We would like to express special thanks of gratitude to our HOD Prof. Kshirsagar as well as Prof Chaure B. M. of our department for their assistance that helped us to do a lot of research and we came to know about so many new things. We are really thankful to them.

### REFERENCES

[1]V.Jafari fesharaki Majid Dehghani, J.Jafari Fesharaki, Hamed Tarasoli, "The effect of tempratue of photovoltaic cell efficiency",first international conference on emerging trend in energy conservation-ETEC Tehran ,Tehran,Iran.

[2]Anna Machniewics,Dominika knera,Dariusz Heim, "Effect of transition temprature on efficiency of PV/PCM",Sixth international building physics conference IBPC 2015 energy procedia 78(2015)1684-1689.

[3]K.A. Moharram M.S. Abd -Elhaldy, H.a. Kandil, H. EI-Sherif,"Enhancing the performance of PV PANELS by water cooling",Ain Shams Engineering Journal(2013)4,869-877.

[4]Catain George Popovici, Sebastian Veleriu Hudisteanu, Theodor Dorin Mateescu, Nelucristian Chereches, "Efficiency improvement of photovoltaic panels by using air cooled heat

simks",sustainable solution for enrgy and enviroment, EENVIR\_YRC 2015,Bucharest, Romana, energy procedia 85(2016)425-432.

[5]Mr. Dinesh S. Borkar,Dr.Sunil V prayagi, Ms. Jayashree Golmare,"Performance Evaluation of Photovoltaic solar panel using Thrmoelectric cooling,International Journal of Engineering research volume No.3,Issue No.9,pp:536-539.