

# DESIGN AND DEVELOPMENT OF H-FRAME WITH LATERAL LINK SUSPENSION FOR AN ALL TERRAIN VEHICLE

Parag Borse<sup>1</sup>, Vaishnav Mayekar<sup>2</sup>, Nilesh Jain<sup>3</sup>

<sup>1,2,3</sup> Department of Mechanical Engineering, Pimpri Chinchwad College of Engineering, Maharashtra, India.

\*\*\*

**Abstract-** All Terrain Vehicle (ATV) as defined by American National Standards Institution ANSI as a vehicle that travels on low pressure tires, which is used to handle any kind of terrain it faces. The paper focuses on design of rear suspension system for an ATV. The paper covers simulation, modelling and analysis of suspension geometry. Suspension is designed such that it provides better handling and better comfort for an ATV.

and keep the tire perpendicular to the ground. This is especially important for the outer tire because of the weight transfer to this tire during a turn. This type of suspension requires hem joints for connecting the linkages. Between the outboard ends of the arms is a knuckle with a spindle (the kingpin), hub, or upright which carries the wheel bearing and wheel.

## 1. INTRODUCTION

A vehicle suspension system is a linkage to allow the wheel to move relative to the body and some elastic element to support loads while allowing that motion.

Most practical vehicles have some form of suspension, particularly when there are four or more wheels.

The primary functions of a suspension system are to:

- To support the vehicle weight
- To separate the vehicle body from road disturbances, and
- To maintain the contact between the tire and the road surface also
- To improve stability and ride comfort of the vehicle
- Resist roll of the chassis.
- React to the control forces produced by the tires-longitudinal (acceleration and braking) forces, lateral (cornering) forces, and braking and driving torques.

### 1.1 H-frame with Lateral links

The rear suspension was selected as H-frames with lateral link, it consists of H-frame and also contains one link in lateral direction which is used to carry lateral load and also controls camber through suspension travel. [1]

The H-frame with camber link consists of the H-frame and two links for controlling the camber throughout the suspension travel and for carrying the lateral loads.

The suspension consists of upper and lower lateral arms. The upper arm is usually shorter to induce negative camber as the suspension jounces (rises). When the vehicle is in a turn, body roll results in positive camber gain on the outside wheel. The outside wheel also jounces and gains negative camber due to the shorter upper arm. [1] The suspension designer attempts to balance these two effects to cancel out

### 1.2 Advantages of H-frame with Lateral Link

This type of suspension carries the following advantages over the other type of suspensions

- Better lateral load handling capacity.
- As this kind of suspension contains two linkages in the lateral direction, the suspension is capable of handling large amounts of lateral loads which are induced during cornering. When a vehicle is taking turn a force equal to the centrifugal force is acted upon the contact patch of the wheel, thus a moment is induced in the suspension components.
- Thus one of the two linkages is in compression and other is in tension.
- Better control over camber throughout the wheel travel.
- The working of H-frame with lateral link is equivalent to double wishbone type suspension system. The linkages form 4 bar linkages and the articulation of each linkage can be controlled as per the requirements simply by changing the lengths of linkages and the positions of the pivot points.
- Better Anti-Squat properties.
- The H-frame can be mounted inclining backwards thus during acceleration the forces generated due to weight transfer are taken by H-frame. [3]
- Plunging of the shafts can be minimised easily.
- As this suspension geometry is equivalent to double wishbone geometry, the plunging of shafts can be minimised by following the ICR geometry which is used for minimising bump steer.

### 1.3 Design and Analysis

The important properties of a suspension related to dynamics are the kinematic (motion) behaviour and its response to the forces and moments that it must transmit from the tires to the chassis. In addition, other characteristics considered in the design process are cost,

weight, package space, manufacturability, ease of assembly, and others

The main factors for the design of the rear suspension are weight, functionality and cost. The rear suspension was identified to be the H-frame, 1 lateral link per side, knuckle, hub, tires and rims. The suspension was designed to maximize travel without affecting other performance parameters. It was required to have negative camber gain in bump and positive camber gain in droop. The allotted weight for this system is 15kg.

### 1.4 Objectives of suspension design

- To provide greater travel. An ATV has to handle rough terrain for which it has to allow better absorption of the shocks during the changes in ground conditions. Thus to travel through larger bumps and ditches, the suspension system requires greater amount of travel.
- To reduce unsprung mass so as to have lesser inertia loads, thus the response time of the suspension to changes in the track surface is minimized. This allows the tire to maintain constant contact with the surface as much as possible.
- To avoid bump steer.
- To provide better handling while cornering by providing camber gain.
- To minimize plunging of CV-joints in rear suspension. This minimizes chances of popping out of the half shafts from gearbox. [3]

### 1.5 Steps for Designing Suspension system

The basic criterion to achieve better handling was to have camber gain in roll. In other words, as the car corners, the goal is to gain negative camber at the outer wheels and to gain positive camber at the inner wheels of the vehicle.

By providing sufficient camber gain the wheels remain vertical to the ground even when the body rolls, which provides better grip while cornering.

Also the roll centre of the rear suspension was kept higher than the roll centre in front to decrease over steering of the vehicle.

The roll centre has a significant impact on a suspension's steering response; moreover, there is a direct correlation between roll centre location and over steer, under steer, or neutral steer suspension behaviour depicted in Figure 17.

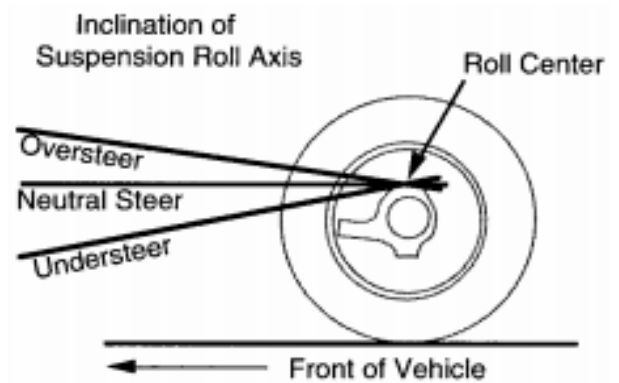

Fig-1: Effect of Roll Axis [5]

To start with the suspension designs firstly the vehicle parameters such as wheel track, wheel base were defined according to the rules specified by SAE BAJA which states that "Maximum dimensions of vehicle should be 64 inches width".

Considering this overall width and the size of the tire and wheel combination, the suspension must be designed such that maximum width at the tire edge surfaces is not more than 64 inches at ride height.

Table 1 shows the various vehicle dimensions decided.

Table -1: Vehicle Dimensions

Vehicle dimensions at ride height	Rear
Width	58 inches
Wheelbase	53 inches
Ground clearance	21 inches

The track width was kept smaller to aid in manoeuvrability. The wheel base was kept minimum to decrease the turning radius. To maximize obstacle avoidance, a ground clearance of 11 inches from the ground to the lowermost member on the chassis was chosen.

Recessional wheel travel is also provided which accounts for the longitudinal forces that arise during the vehicle approaches a bump.

Table 2 shows various design parameters of the suspension.

Table -2: Suspension System Parameters

Parameter	Value	
	Front suspension	Rear suspension
Suspension travel in Jounce	6 inches	6 inches
Suspension travel in droop	2 inches	2 inches
Roll centre height	13.7 inches	10

Camber	10	10
Toe in	00	00
Camber gain per degree roll	0.70	0.70
Recessional wheel travel	1 inch	1 inch
Stiffness (k) (N/mm)	Variable	Variable
Damper travel	6 inches	6 inches

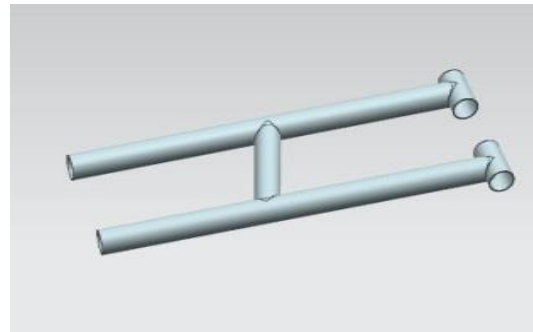

Fig-3: H-Frame

### 1.6 Design of Suspension Geometry

The suspension geometry was obtained by using instantaneous centre method so as to have minimum bump steer in front and minimum plunging of shafts in rear geometry. The lengths of the wishbones, tie rods, H-frame, Lateral link and half shaft were obtained from the geometry. The Geometry obtained by using Instantaneous Centre Method .

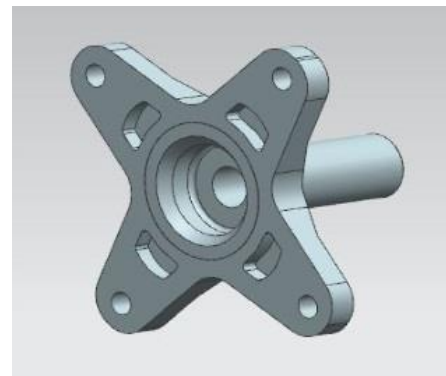

Fig-4: Rear Hub

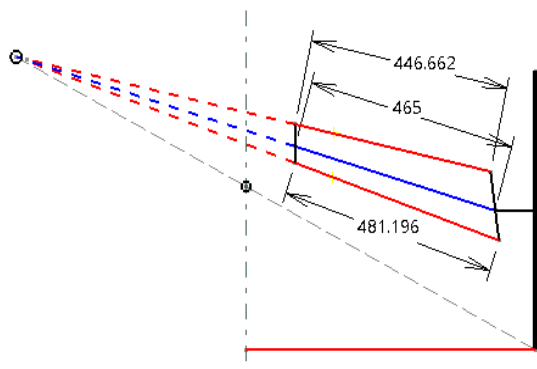

Fig-2: Suspension Geometry (determination of link lengths) AutoCAD Drawing

The mounting of the front suspension was made on nose. The shock absorber was mounted on front bracing member. The mounting of the rear suspension and shock absorber was made on engine compartment members.

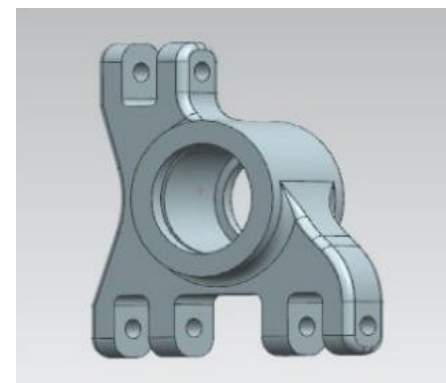

Fig-5: Rear Knuckle

### 1.7 Design and Modelling of the Suspension Components

The components to be designed are as follows

- H-frame
- Lateral link
- Knuckle
- Wheel hub
- Shock absorber (Selection)

The various suspension components were modeled using uni graphics software as shown below.



Fig-6: Rear Assembly

### 1.8 Analysis of the Suspension Components

For analysing the components ANSYS software was used in which the components were analysed for combined loading of the forces. Then according to the results the changes were made in the components so as to meet the objectives.

Following loads were applied for analysing the suspension components:

The forces acting on them are

1. Longitudinal forces: - These forces arise due to braking and drive line forces acting on the components. The drive line forces are mostly taken by the H-frame and the braking forces are carried by the wheel hub and the bearing carrier.
2. Lateral forces: - When a vehicle is taking turn a force equal to the centrifugal force is acted upon the contact patch of the wheel, thus a moment is induced in the suspension components and this load is carried by the camber links as well as the bearing carrier.
3. Vertical forces: - These forces arise due to the bumps in the ground. Usually 3g loads are acting on the components in case of bumps.

### 1.9 Calculations of Forces:

1) Forces due to reaction from the ground:

a) Forces due to self-weight:

$$F1 = \frac{mg}{4}$$

b) Dynamic forces on suspension components is considered to be 3 times the self-weight:

$$F2 = 3 \times F1$$

Considering weight of vehicle = 220 kg

$$F2 = 6474.6 \text{ N}$$

2) Forces arising while cornering:

While cornering centrifugal forces are acting on the vehicle & to keep the vehicle stable reactions are acting in the opposite direction at the contact patch of wheel. As the force is acting at a distance equal to the radius of wheel, thus a moment is acting on the suspension components due to lateral forces. Let

M= moment acting on suspension components

R= radius of turn while cornering

r= radius of wheel

F<sub>l</sub>=lateral forces/reactions at wheel

F<sub>c</sub>=centrifugal force

F<sub>r</sub>=radial force

$$F_c = \frac{mv^2}{R}$$

$$= \frac{220 \times 9.85^2}{4}$$

$$= 4307.7375 \text{ N}$$

Considering a fraction of centrifugal force acting on rear wheels.

$$F_r = 4307.73 \times 0.5$$

$$= 2153.86 \text{ N}$$

While cornering the weight of the vehicle is transferred to outer wheels.

Thus it can be assumed that the centrifugal force is completely acting on the outer wheels.

Moment acting on suspension components

$$M = F_r \times r$$

$$= 2153.86 \times 11 \times 0.0254$$

$$= 602 \text{ Nm}$$

3) Longitudinal Forces:

The longitudinal forces arise due to braking action

$$M_b = \text{braking moment} = 161 \text{ Nm}$$

Following loads were applied for analysing the rear suspension components.

**Table -3:** Forces acting on Suspension Components

DIRECTION	FORCE/MOMENT
LONGITUDINAL	161 Nm
LATERAL	602 Nm
VERTICAL	3G N

The calculated forces were the used to analyse the components in Ansys. The Ansys results of H-frame, knuckle, stub, hub, are shown in Figure19, 20, 21,22,23,24

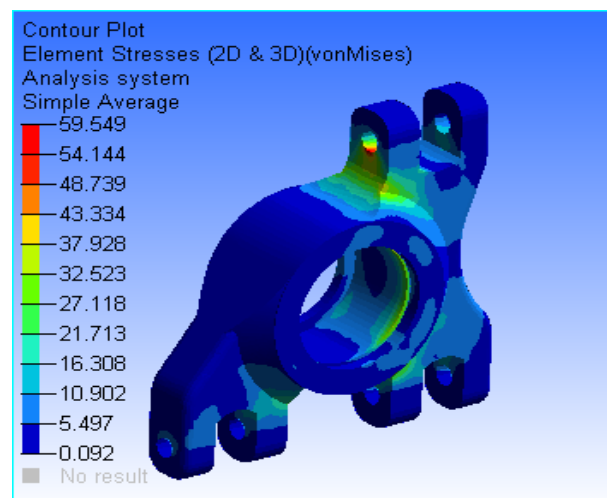

**Fig-7:** Rear Knuckle

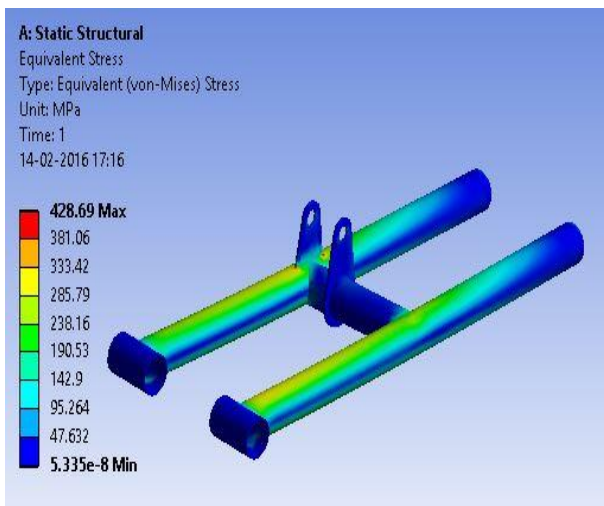

Fig-8: H-frame

Table -4: Results of FEA

Components	$\sigma_{max}$ (MPa)	Factor of safety
Front Hub	92.77	2.97
Front Knuckle	58.24	4.73
Lower wishbone	542.93	1.33
Stub axle	383.72	1.88
Rear knuckle	59.55	4.63
H-frame	428.69	1.6

1.10 H-frame and Specification:

Table -5: H-frame and wishbones Specifications

Material	Mild Steel
Carbon %	0.4%
Cross-section	Circular
Diameter	1"
Thickness	1.6 mm

1.11 Problem faced:

H-frame mounting brackets failed in shearing, because of misalignment of mounting bushes.

1.12 Selection of Shock Absorber

Fox air suspension was selected which provides easy adjustment of stiffness, ride height and rebound velocity. The Fox air suspension also helped reducing the unsprung mass with its light weight body made of 6061 aluminium

alloy and weighs around 1.6 kg only. Fox suspension has 2 air chambers namely main chamber and evol chamber. Fox stiffness varies with main chamber pressure and ride height varies with pressure in evol chamber.



Photograph -1: Fox Shock Absorber

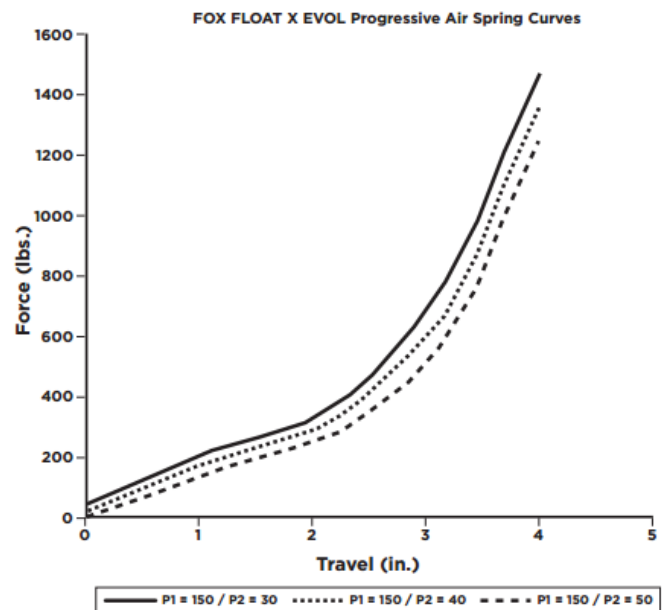

Fig -9: Air spring curve Restoring force vs Travel

1.13 Assembly of Parts

After manufacturing of all the parts, assembly of the manufactured parts was done finally. The process sheet for the assembly is as following



Photograph -2: Assembly of rear hub and knuckle



Photograph -5: Suspension response over bumps



Photograph -3: Assembly of rear suspension



Photograph -6: Testing of suspension system

## 2. VALIDATING AND TESTING

Testing of the front and rear suspension was done for over 450km on the rough terrain. For almost 120km there were no major failures experienced.



Photograph -4: Suspension response in trenches

## 3. CONCLUSION

The components of the suspension system are analysed in ANSYS Workbench 14.0 software. Using Grid Sensitivity Analysis the optimum mesh size for the components are obtained.

The entire suspension geometry was simulated with the help of suspension simulation software, which provides us with the verification of suspension hard points.

The results obtained from simulation proves that the tyre remains perpendicular to the ground surface during the cornering of the vehicle, thereby providing better grip with the help of sufficient camber gain.

The results obtained from simulation software also proves that the toe change for the proposed geometry was minimum, thus minimizing the bump steer of the vehicle. The suspension hard points were so adjusted that the plunging of drive shafts is minimized.

The total suspension travel is 8 inches; 6 inches in bump and 2 inches in droop.

Thus the objective of designing a light weight and rugged suspension system for an all-terrain vehicle is achieved.

#### 4. REFERENCES

- 1) Auburn University "2010 Baja SAE Suspension"
- 2) John C. Dixon "Suspension Geometry And Computations"
- 3) Nick Brookman "Baja SAE Rear Suspension Design" SAE international, April 2007
- 4) PSG College of Engineering "Design Data"
- 5) Robert Casion "2007-08 WPI SAE Baja Vehicle"
- 6) Thomas d. Gillespie "Fundamentals of Vehicle Dynamics"

#### 5. BIOGRAPHIES



**Parag Borse**

A mechanical engineer from Savitribai Phule Pune University. Prowess in Suspension and manufacturing processes.



**Vaishnav Mayekar**

A mechanical engineer from Savitribai Phule Pune University. Prowess in Rollcage and CAD/CAE



**Nilesh Jain**

A mechanical engineer from Savitribai Phule Pune University. Prowess in Drive shaft and manufacturing process



**Dhanraj Shinde**

A mechanical engineer from Savitribai Phule Pune University. Prowess in steering systems and CAD/CAE