

DESIGN AND ANALYSIS OF SHOCK ABSORBER

¹A. Chinnamahammad bhasha, ²N. Vijay rami reddy, ³B. Rajnaveen

¹ M.Tech Student, Dept of ME, Vignan University, India.

^{2,3}Asst proof, Dept of ME, Mahatma Gandhi Institute of Technology, Hyd, India.

Abstract -Shock absorber is a mechanical device designed to smooth out or damp shock impulse, and dissipate kinetic energy. In a vehicle, it reduces the effect of traveling over rough ground, leading to improved ride quality, and increase in comfort due to substantially reduced amplitude of disturbances. In this work suspension system is designed and a 3D model is created using CATIA V5 R21. The model is also changed by changing the thickness of the spring. Structural analysis and modal analysis are done on the shock absorber by varying different spring materials. Spring materials are Spring Steel, Phosphor bronze, Beryllium Copper and Titanium alloy. To validate the strength of the model, the structural analysis on the helical spring was done. The analysis is done by considering loads, bike weight, and single, double riding. Modal analysis is done to determine the displacements for different frequencies for number of modes. Finally comparison is done for different materials to verify best material for spring in Shock absorber. Modeling is done in CATIA and analysis is done in ANSYS.

Keywords: Static, Transient Dynamic, Buckling, CATIA V5 R21, ANSYS.

I.INTRODUCTION

A shock absorber or damper is a mechanical device designed to smooth out or damp shock impulse, and dissipate kinetic energy. Pneumatic and hydraulic shock absorbers commonly take the form of a cylinder with a sliding piston inside. The cylinder is filled with a fluid (such as hydraulic fluid) or air. This fluid-filled piston/cylinder combination is a dashpot. The shock absorbers duty is to absorb or dissipate energy. These are an important part of automobile suspensions, aircraft landing gear, and the supports for many industrial machines. Large shock absorbers have also been used in structural engineering to reduce the susceptibility of structures to earthquake damage and resonance. A transverse mounted shock absorber, called a yaw damper, helps keep railcars

from swaying excessively from side to side and are important in commuter railroads and rapid transit systems because they prevent railcars from damage station platforms. In a vehicle, it reduces the effect of traveling over rough ground, leading to improved ride quality, and increase comfort due to substantially reduced amplitude of disturbances. Without shock absorbers, the vehicle would have a bouncing ride, as energy is stored in the spring and then released to the vehicle, possibly exceeding the allowed range of suspension movement. Control of excessive suspension movement without shock absorption requires stiffer (higher rate) springs, which would in turn give a harsh ride. Shock absorbers allow the use of soft (lower rate) springs while controlling the rate of suspension movement in response to bumps. Damp the motion of the upspring weight up and down on the springiness of the tire. Since the tire is not as soft as the springs, effective wheel bounce damping may require stiffer shocks than would be ideal for the vehicle motion alone. Spring-based shock absorbers commonly use coil springs or leaf springs, though torsion bars can be used in tensional shocks as well. Ideal springs alone, however, are not shock absorbers as springonly store and do not dissipate or absorb energy. Vehicles typically employ springs and torsion bars as well as hydraulic shock absorbers. In this combination, "shock absorber" is reserved specifically for the hydraulic piston that absorbs and dissipates vibration.

There are a number of different methods of converting an impact /collision into relatively smooth cushioned contact.

- Metal Spring
- Rubber Buffer
- Hydraulic Dashpot
- Collapsing safety Shock Absorbers

- Pneumatic Cylinders
- Self compensating Hydraulic

II. DESIGN CALCULATIONS FOR HELICAL SPRINGS FOR SHOCK ABSORBERS

Material: Steel (modulus of rigidity) $(G) = 41000$ N/mm²

Mean diameter of a coil $(D) = 62$ mm

Diameter of wire $(d) = 8$ mm

Total no of coils $(n_1) = 18$ Height $(h) = 220$ mm

Outer diameter of spring coil $(D_0) = D + d = 70$ mm

No of active turns $(n) = 14$

Weight of bike $(w) = 125$ kgs

Let weight of 1 person = 75Kgs

Weight of 2 persons = $75 \times 2 = 150$ Kgs

Weight of bike + persons = 275Kgs

Rear suspension = 65%

65% of 275 = 165Kgs

Considering dynamic loads it will be double

$(W) = 330$ Kgs = 3234N

For single shock absorber weight = $(w/2) = 1617$ N = (W)

Spring index $\phi = 7.75 = 8$

Solid length $(L_s) = n_1 \times d = 18 \times 8 = 144$ mm

Free length of spring (L_f)

$(L_f) =$ solid length + maximum compression + clearance between adjustable coils

$(L_f) = 144 + 282.698 + 0.15 \times 282.698$

$(L_f) = 469.102$

Spring rate $(K) = 5.719$ Pitch of coil,

Stresses in helical springs $(P) = 26$

Maximum shear stress induced in the wire $(\tau) = 499.519$ N/mm²

Values of buckling factor $(KB) = 0.05$ (for hinged and spring)

The buckling factor for the hinged end and built-in end springs $(W_{cr}) = 5.719 \times 0.05 \times 469.102 = 134.139$ N

III. DESIGN PROCEDURE FOR SHOCK ABSORBER

3.1 Design of upper mount

Draw a circle with 60mm diameter and 30mm diameter, thickness 10mm, rectangle length 50 mm and width 25mm

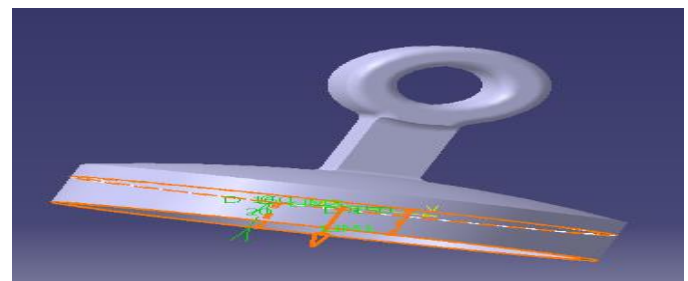
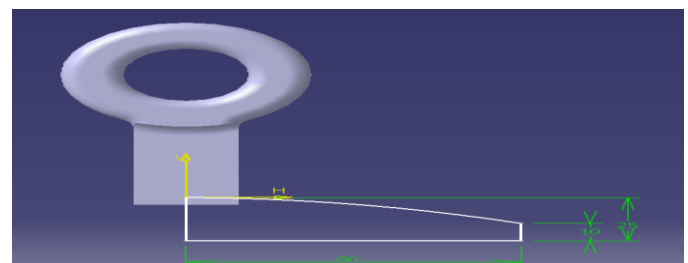
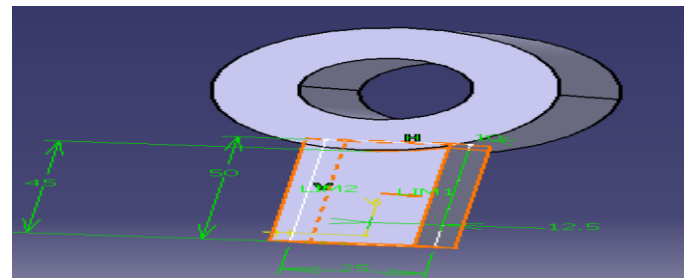

Fig.3.1 Design of upper mount

3.2 DESIGN OF BOTTOM MOUNT

Draw a circle with 160mm diameter and 150mm diameter, thickness 20mm, rectangle length 80 mm

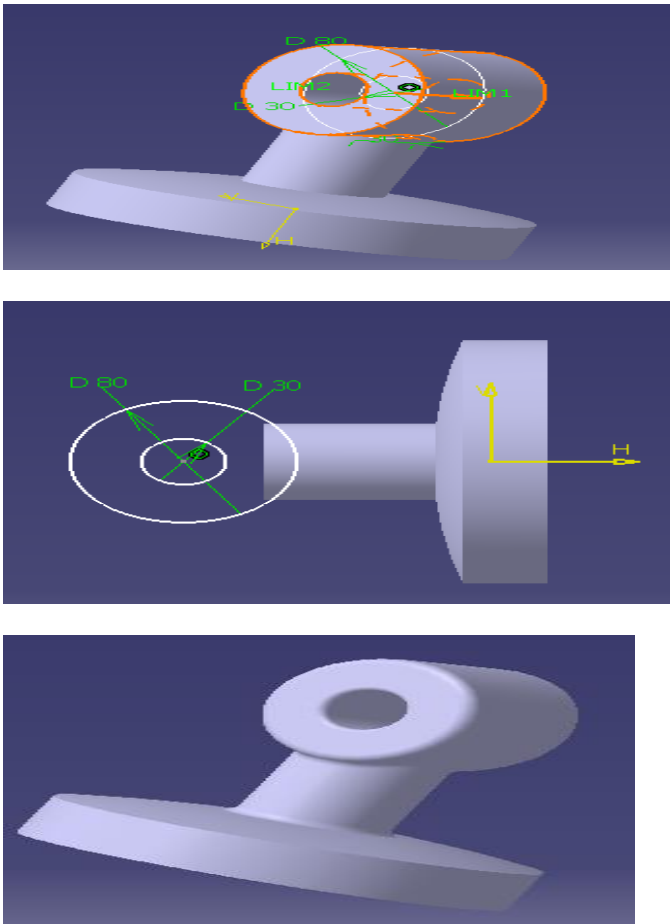

Fig.3.2. Design of bottom mounts

3.3 Design of oil Pad

Draw a circle of 80 mm diameter, length of 180 mm, the helix of pitch 15 mm, a circle of 20 mm diameter, depth 150mm.

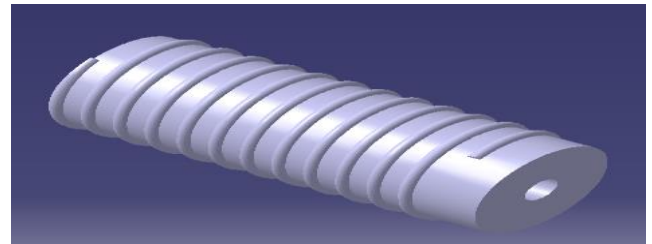
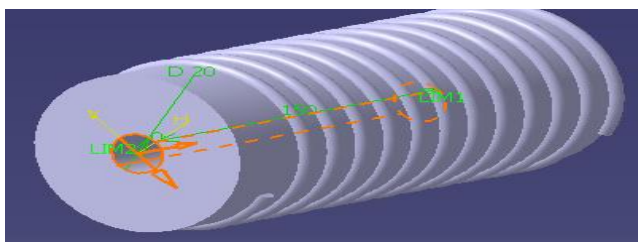

Fig.3.3. Design of oil Pad

3.4 Design of Rod

Draw a circle of 20 mm diameter, 300 mm length, a pitch of 50 mm and height of 400 mm

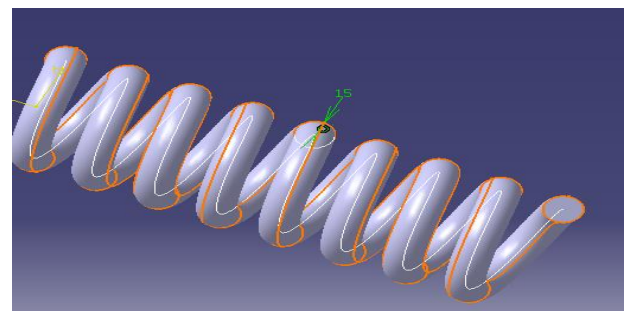
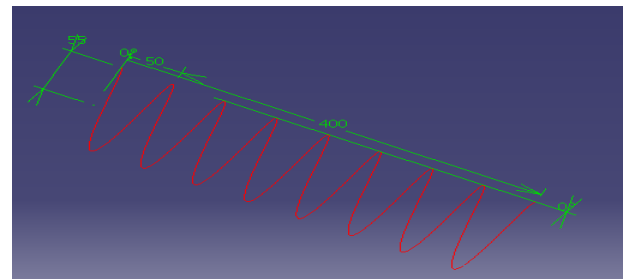

Fig.3.4. Design of oil Pad

3.4 Assembly Module

- In the Assembly module of CATIA insert all the existing such as upper mount, lower mount, strip rod, spring and oil Pad.
- Assemble it step by step by using different tools like coincide, offset, and contact constrain, Manipulation, Smart Move and Etc..... As shown in below.

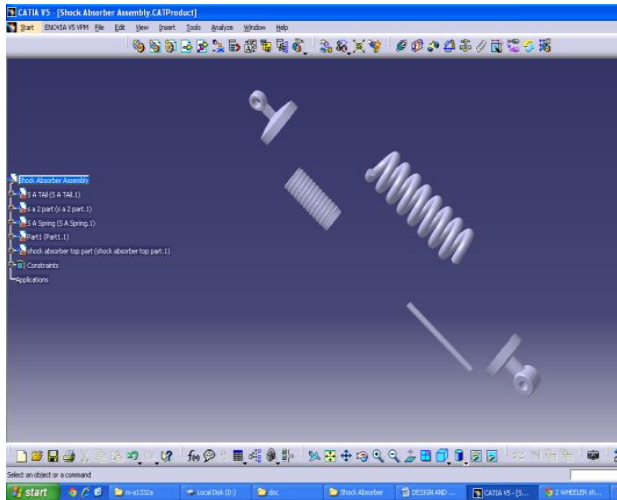

Fig.3.5 different engineering materials present in CATIA V5 R21.

IV.INTRODUCTION TO ANSYS

Finite Element Analysis is a numerical method of deconstructing a complex system into very small pieces (of user-designated size) called elements. The software Implements equations that govern the behavior of these elements and solves them all; creating a comprehensive explanation of how the system acts as a whole. These results then can be presented in tabulated or graphical forms.

4.1. STEPS IN FINITE ELEMENT ANALYSIS:

STEP 1:

First the domain is represented as finite elements. This is called descritization of domain. Mesh generation programs called processors, help in dividing the structure.

STEP 2:

Formulate the properties of each element in stress analysis. It means determining the nodal loads associated with all element deformation stress that is allowed.

STEP 3:

Assemble elements to obtain the finite element model of the structure.

STEP 4:

Apply the known loads, nodal forces in stress analysis. In stress analysis the support of the structure has to be specified.

STEP 5:

Solve simultaneous line algebraic equations to determine nodal displacements in the stress analysis.

STEP 6:

Postprocessors help the user to sort the output and display in the graphical output form.

A typical finite element model is comprised of nodes, degrees of freedom, elements material properties, externally applied loads and analysis type.

The finite element method is a numerical analysis technique for obtaining approximate solutions to a wide range of engineering problems.

4.2. ASSUMPTIONS IN FEA

The four primary assumptions, which must be considered in any Finite element based solution, be it structural, electromagnetic, fluid flow or manufacturing simulation is:

1. Geometry
 2. Material properties
 3. Mesh
 4. Boundary conditions
- Import the model in to the geometry section of the ANSYS work bench as shown below.

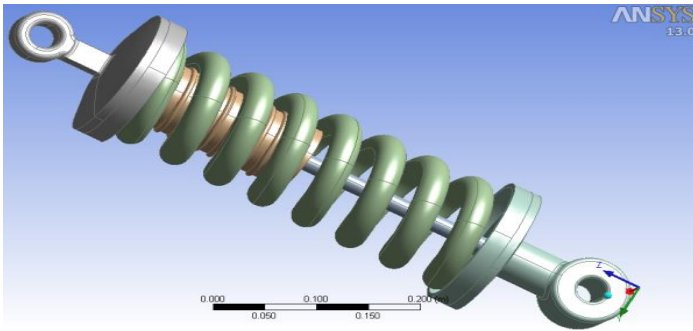

Insert the Fixed support at one end and force of 1000 N at one end as shown below.

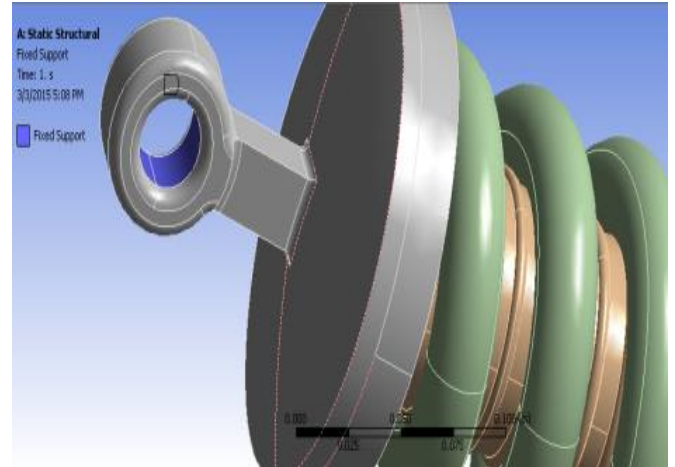

4.3. Material Properties

| Sl.no | Material | Young's Modulus (N/mm ²) | Density(K g/mm ³) | Poisson's ratio |
|-------|-----------------|--------------------------------------|-------------------------------|-----------------|
| 1 | Spring steel | 202000 | 7820 | 0.292 |
| 2 | Phosphor Bronze | 103000 | 8160 | 0.34 |
| 3 | Copper alloy | 130000 | 8100 | 0.285 |
| 4 | Titanium alloy | 102000 | 4850 | 0.3 |

Directional Deformation

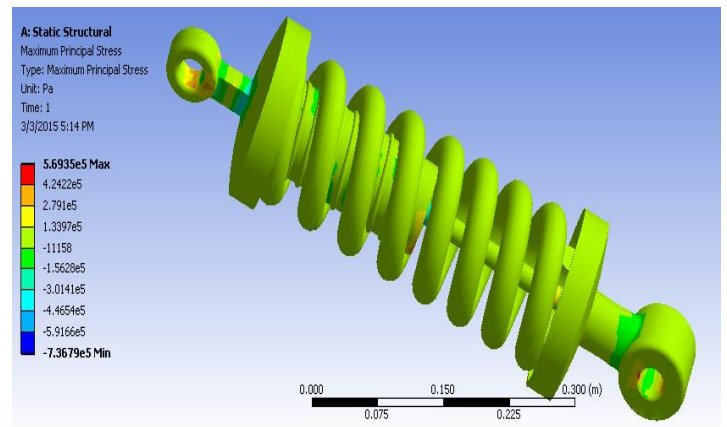

Generate the mesh of the imported component as shown below.

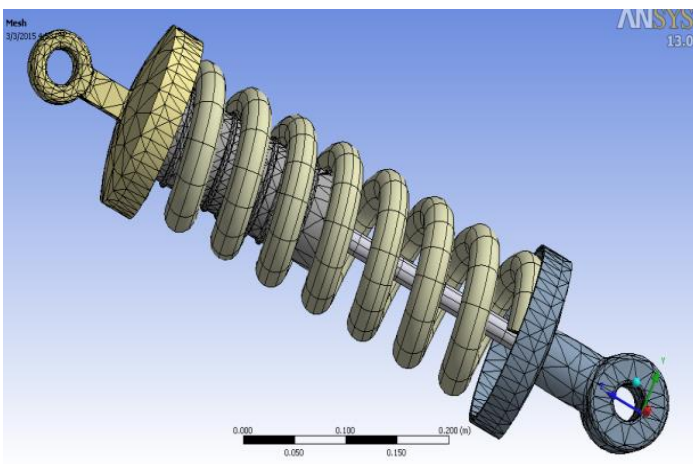

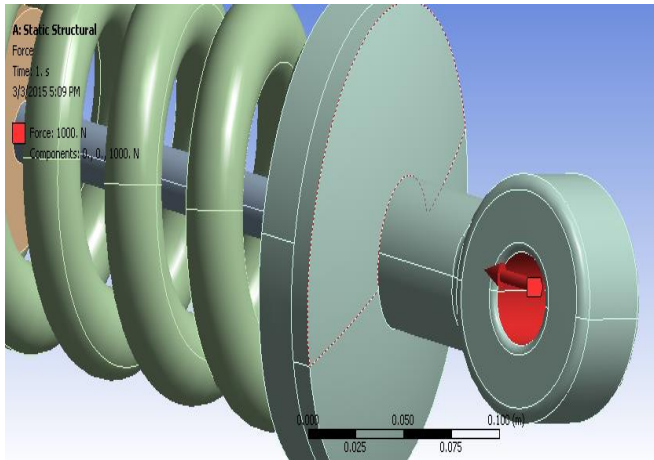

Maximum Principal Stress

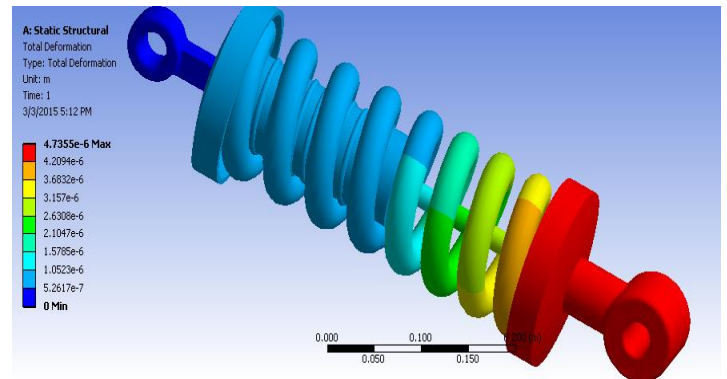

Equivalent Stress

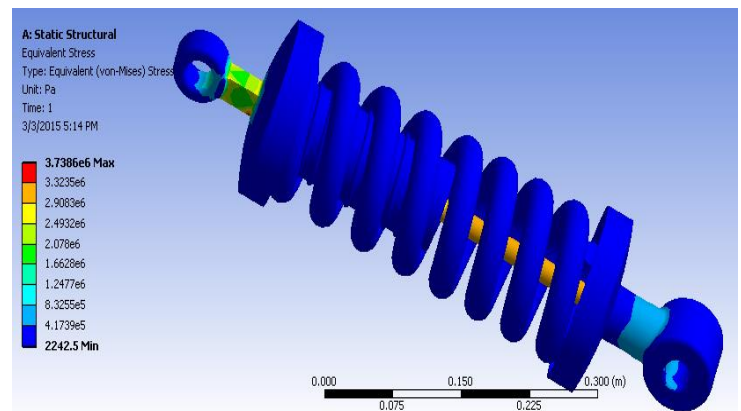
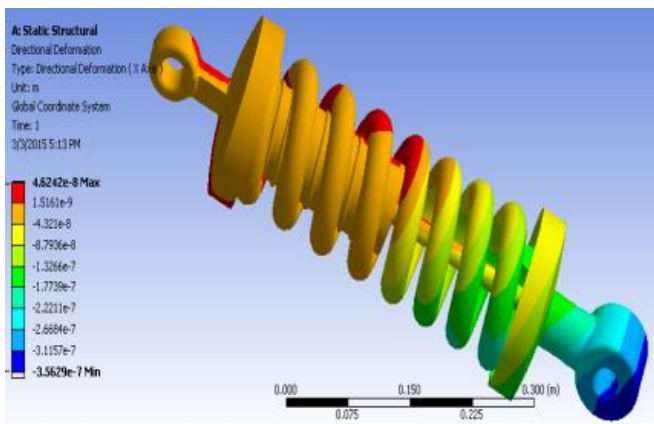

Total Deformation.

V. RESULTS AND DISCUSSION

In this project the helical spring of a shock absorber by using 3D parametric software CATIA. And also the analysis was performed by using ANSYS is a general purpose finite element analysis (FEA) software package. To validate the strength of the model, the structural analysis on the helical spring was done by

varying different spring materials like steel, titanium alloy, copper alloy and Phosphor bronze Modal analysis is done to determine the displacements for different frequencies for Number of modes. The maximum displacements and stress intensities of the respective materials are given below. To validate the strength of our design, we have done structural Analysis.

| Sl. No | parameters | Titanium alloy | Phosphor bronze | Beryllium Copper | Spring steel |
|--------|---|----------------|-----------------|------------------|--------------|
| 1 | Maximum displacement (mm) | 2.6326 | 4.9247 | 4.8582 | 3.0123 |
| 2 | Maximum stress intensity (N/mm ²) | 36.102 | 36.5865 | 36.4637 | 36.4265 |

- I. Materials are Spring Steel, Phosphor Bronze, Beryllium Copper and Titanium alloy.
- II. The stress intensity and displacement vectors are less for titanium alloy than other materials. So, the best material for spring is titanium alloy.
- III. Also the shock absorber design is modified by reducing the diameter of spring by 2mm and structural, modal analysis is done on the shock absorber. By reducing the diameter, the weight of the spring reduces. By comparing the results for different materials, the stress value is less for Titanium alloy than Beryllium Copper, phosphor Bronze and spring steel.
- IV. By comparing the results for present design and modified design, the stress and displacement values are less for modified design.

- V. So we can conclude that as per our analysis using material Titanium alloy for spring is best and also our modified design is safe.
- VI. From the analysis results it is clear that the optimal stress intensities & maximum displacement values are obtained for the titanium alloy material.
- VII. Therefore, when the availability of titanium alloy is more and cost of titanium material is affordable then the scope of materials for springs with titanium alloy is preferable.

VII. REFERENCES

- I. Machine design by R.S.KURMI
- II. PSG, 2008."DESIGN DATA," *kalaikathir achachgam* publishers, COIMBATORE, INDIA
- III. Automobile Engineering by *R.B.Gupta*
- IV. Automobile Engineering by *G.B.S. Narang.*
- V. Automobile Servicing and Maintenance by *K.Ashrif Ali*
- VI. Automotive Maintenance and Trouble Shooting by *Ernest Venk,& Edward D. Spicer*
- VII. www.alibaba.com
- VIII. En.wikipedia.org/coil springs.
- IX. En.wikipedia.org/history of helical spring.
- X. En.wikipedia.org/