

POWER QUALITY IMPROVEMENT BY SERIES ACTIVE POWER FILTER- A REVIEW

Ankita P. Bagde¹, Rupali B. Ambatkar², Rupali G. Bhure³, Prof. Bhushan S. Rakhonde⁴

¹ UG, Electrical Engineering Department, DES'sCOET, Maharashtra, India

² UG, Electrical Engineering Department, DES'sCOET, Maharashtra, India

³UG, Electrical Engineering Department, DES'sCOET, Maharashtra, India

⁴Assistant Professor, Electrical Engineering Department, DES'sCOET, Maharashtra, India

Abstract - The power quality problem faces different power quality issues due to the increased use of power electronics based equipment of modern power system. To overcome these different power quality problems series active power filter is used which provides voltage compensation, power quality problem like voltage sag, voltage swell and provide compensation for harmonics in supply voltage i.e. when supply voltage is unbalanced and distorted. The voltage quality is one of the major concerns for industrial and distribution consumers. In this paper the series active power filter for voltage compensation has been verified using vectorial power theory for three phase system with non linear load and the control scheme provide better unbalance voltage compensation and voltage regulation for three phase system with non linear load. The proposed filters can improve the distortion of non-linear loads power. The problem of harmonics due to non linear load can be reduced by the series active power filter. The series active power filter is applied as a controlled voltage source contrary to its common usage as variable impedance. It reduces the terminal harmonic voltages, supplying nonlinear loads with a good quality voltage waveform. The operation principle, control strategy, and theoretical analysis of the active filter are presented.

Key Words: FACTS, POWER QUALITY, SAPF, THD, UPQC.

1. INTRODUCTION

Power quality is nothing but the better quality of power supplied to the electrical equipment. It determines the fitness of electrical power. The main reasons of poor power quality are distortion in voltage and current, low power factor etc. these distortion in voltage and current is occur due to the increased use of nonlinear load. by using different method we can improve the power quality and customer will get good quality of power. The harmonics contamination is serious and harmful problem in electrical power system. To overcome these problem active power filters is one of the most effective solutions. Depending on the particular application or electrical problem to be solved, active power

filters can be implemented as shunt type, series type, or a combination of shunt and series active filters (UPQC). The series active power filter is mainly work as a voltage controller and harmonic isolator. The series active power filter protects the customer from poor quality of power. The design and modelling of series active power filter for compensation of harmonics and reactive power are discussed.

1.1 POWER QUALITY PROBLEMS

The power quality problem is defined as “any disturbance occurred in the voltage, current, frequency deviation that result in damage, upset, failure of electrical equipment. The main cause of poor power quality is as follows:

- Voltage sag
- Voltage swell
- Transients
- Voltage imbalance
- Voltage flicker
- Voltage waveform distortion
- Harmonic reduction

2. MODELING OF SERIES ACTIVE POWER FILTER

The active power filter connected in series to the power distribution system is called as series active power filter. The series active power filter compensate current system distortions caused by the nonlinear load, it provides the high impedance path to the current harmonics which forces the high frequency currents to flow through the LC passive filter connected in parallel to the load. The series active power filter injects a voltage component in series with the supply voltage and hence it acts as a controlled voltage source, compensating voltage sags and swells and on the load side. The main function of series active power filter is to protect the sensitive loads from voltage sag, swell, harmonics. The rated power of series active power filter is the small fraction of load however; the apparent power of series active power filter may increase in case of voltage compensation.

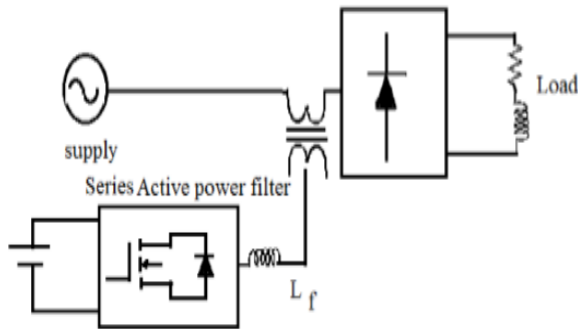

Fig. 1: Block Diagram Of Series Active Power Filter

The block diagram of series active power filter consists of three phase supply, series active power filter, and nonlinear load. The three phase power systems have at least three conductor carrying alternating current voltages that are offset in time by one-third of the period. A three phase system may be arranged in delta or star. The star system allows the use of two different voltages from all three phases, such as a 230/400 v system which provides 230 v between the neutral and any one of the phases, and 400 v across any two phases. A delta system provides one voltage magnitude, however it has a greater redundancy as it may continue to operate normally with one of the three supply winding offline, the harmonics currents in neutral may become very large if non linear loads are connected. In these due to the non linear load the load voltage and current get distorted hence it is necessary to remove the distortions hence the series active power filter is connected at the source side which is shown in fig. 1 above. The series active power filter injects the voltage component of harmonics in series with the supply voltage. So that it can compensate harmonics and maintaining the power supply. For the requirement of improving harmonic compensation performance, power factor improvement and reducing the size of an active power filter, a series active power filter is used. Series active power filter is cost effective and easy to implement. A load is considered non-linear if its impedance changes with the applied voltage. The changing impedance means that the current drawn by the non-linear load will not be sinusoidal even when it is connected to a sinusoidal voltage. These non sinusoidal currents contain harmonic currents that interact with the impedance of the power distribution system to create voltage distortion that can affect both the distribution system equipment and the loads connected to it. In the past, non-linear loads were primarily found in heavy industrial applications such as arc furnaces, large variable frequency drives (VFD), heavy rectifiers for electrolytic refining, etc.

3. CONTROL SCHEME FOR SAPF

The simple control strategy is developed for Series APF which is shown below in fig. 2. It consists of PLL Based Unit Vector Template, Current Control Unit, Gating Signal Generator and Reference Voltage Generator. In the PLL Based Unit Vector Template V_{sa} , V_{sb} , V_{sc} are the input supply voltages which are multiplied by gain $K=1/V_m$ before passing through a phase locked loop. Thus unit vector templates U_a , U_b , U_c are generated. For getting the reference voltages these unit vector templates are compared by pick amplitude of fundamental input voltage.

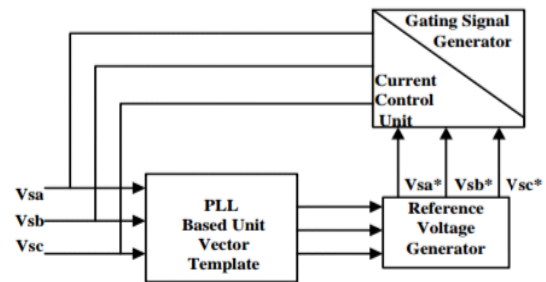

Fig. 2: Control Scheme of Series APF

A phased lock loop (PLL) which synchronizes measured positive sequence component of the current with self generated current. The output of the PLL is used to compute the direct axis and quadrature axis components of the voltages and current. A voltage reference is an electronic device that ideally produces a fixed voltage irrespective of the loading on the device, power supply variations, temperature changes and the passage of time. Voltage references are used in power supplies, analog to digital converters, digital to analog converter, and other measurement and control systems. Voltage references vary widely in performance; a regulator for a computer power supply may only holds its value to within a few percent of nominal value, whereas laboratory voltage standard have precisions and stability measured in parts per million. The control unit and the power circuit and the control unit consist of reference signal generation, gate signal generation, and capacitor voltage balance control and voltage/current measurement. A signal generator is an electronic device that generates repeating or non repeating electronic signal in either the analog or digital domain. It is generally used in designing, testing, troubleshooting and preparing electronic or electro acoustic devices, though it often has an artistic uses as well. There are many different types of signal generator with different purposes and applications and at varying levels of expense.

3.1 REFERENCE VOLTAGE GENERATION

The in-phase sine and cosine outputs from the Phase Locked Loop are used to compute the supply in phase, 1200 displaced in three unit vectors (ua, ub, uc) as

$$\begin{bmatrix} u_a \\ u_b \\ u_c \end{bmatrix} = \begin{bmatrix} 1 & 0 \\ -\frac{1}{2} & -\frac{\sqrt{3}}{2} \\ -\frac{1}{2} & \frac{\sqrt{3}}{2} \end{bmatrix} \times \begin{bmatrix} \sin \theta \\ \cos \theta \end{bmatrix}$$

The computed three in-phase unit vectors are then combined with the desired peak value of the PCC phase voltage (V*in), which become the three phase reference PCC voltages

$$\begin{pmatrix} V_{ia}^* \\ V_{ib}^* \\ V_{ic}^* \end{pmatrix} = V_{im} \cdot \begin{pmatrix} u_a \\ u_b \\ u_c \end{pmatrix}$$

4. SRF METHOD

The synchronous reference frame theory or d-q theory is based on time-domain reference signal estimation techniques. It performs the operation in steady-state or transient state for generic voltage and current waveforms. It allows controlling the active power filters in real time system.

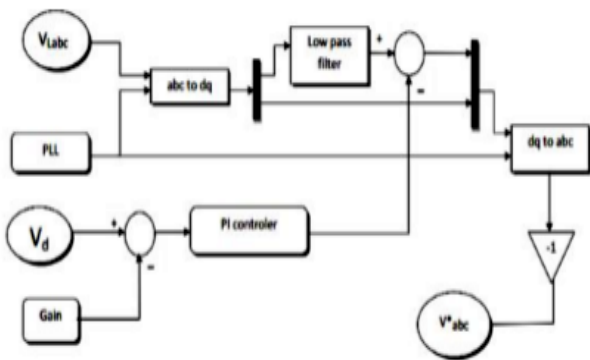

Fig. 3: Synchronous d-q Reference Frame Based Compensation Algorithm

Another important characteristic of this theory is the simplicity of the calculations, which involves only algebraic calculation. The basic structure of SRF controller consists of direct (d-q) and inverse (d-q)-1 park transformations as shown in fig. above. These can be useful for the evaluation of a specific harmonic component of the input signals. The reference frame transformation is formulated from a three phase a-b-c stationary system to the direct axis (d) and quadratic axis (q) rotating co-ordinate system. In a-b-c, stationary axes are separated from each other by 1200.

The d-q transformation output signals depend on the load current (fundamental and harmonic components) and the performance of the phase locked loop (PLL). The PLL circuit provides the rotation speed (rad/sec) of the rotating reference frame, where ωt is set as fundamental frequency component. The PLL circuit provides the vectorized 50 Hz frequency and 30° angle followed by sinθ and cosθ for

synchronization. The id-iq phase current are sent through low pass (LPF) for filtering the harmonic components of the load current, which allows only the fundamental frequency components. The LPF is a second order Butterworth filter, which's cut off frequency, is selected to be 50 Hz for eliminating the higher order harmonics. PI controller is used to eliminate the steady-state error of the DC component of the d-axis reference signals. Furthermore; it maintains the capacitor voltage nearly constant. The DC side capacitor voltage of PWM voltage source inverter is sensed and compared with desired reference voltage for calculating the error voltage. This error voltage is passed through a PI controller whose propagation gain (KP) and integral gain (KI) is 0.1 and 1 respectively.

5. RESULT AND DISCUSSION

We discussed power quality problem, issues etc., and various remedies over it. We used series active power filter to overcome the problem related with power quality issue. The series APF is developed for harmonic and voltage distortion compensation of the non linear load.

6. CONCLUSION

In this paper work on power quality issues were discussed and series active power filter is proposed to mitigate voltage harmonics. The control technique is based on the elimination of both the negative and zero sequence components from the supply voltage followed by the regulation of the remaining component. In general, the series active power filter reduces effectively the voltage total harmonic distortion providing better power quality than it is available on the main.

REFERENCES

- [1] C.Nalini Kiran, "Power Quality Improvement Using Active and Passive Power Filter", *International Journal of Modern Engineering Research*, ISSN: 2249-6645 vol.2, issue.11, pp. 076-079.
- [2] Dr. K. Vandirajacharya, "Series Active Power Filter for Mitigation of Different P-Q Problems", *International conference on Recent Inovotion in Science* ISBN: 978-81-931039-1-3 June-2016, pp-130-137.

- [3] Enio R. Ribeiro and Ivo Barbi, "Harmonic Voltage Reduction Using a Series Active Filter Under Different Load Conditions", *IEEE Transactions on Power Electronics*, vol. 21, no. 5, September 2006, pp-1394-1402.
- [4] P. Salmerón and S. P. Litrán, "Improvement of the Electric Power Quality Using Series Active and Shunt Passive Filters", *IEEE Transactions on Power Delivery*, vol. 25, no. 2, April 2010, pp-1058-1067.